

Public-law institution jointly founded by the federal states and the Federation

European Technical Assessment Body  
for construction products



## European Technical Assessment

ETA-24/0664  
of 12 August 2024

English translation prepared by DIBt - Original version in German language

### General Part

Technical Assessment Body issuing the European Technical Assessment:

Deutsches Institut für Bautechnik

Trade name of the construction product

HECO-VB (HVB)

Product family to which the construction product belongs

screws as fasteners in wood-concrete composite slab kits

Manufacturer

HECO-Schrauben GmbH & Co. KG  
Dr.-Kurt-Steim-Straße 28  
78713 Schramberg  
GERMANY

Manufacturing plant

HECO-Schrauben GmbH & Co. KG  
Dr.-Kurt-Steim-Straße 28  
78713 Schramberg

S.C. HECO Schrauben S.R.L.  
Str. Laminoristilor Nr. 159  
RO-405100 CAMPIA TURZII  
RUMÄNIEN

This European Technical Assessment contains

16 pages including 6 annexes which form an integral part of this assessment

This European Technical Assessment is issued in accordance with Regulation (EU) No 305/2011, on the basis of

EAD 130090-00-0303

The European Technical Assessment is issued by the Technical Assessment Body in its official language. Translations of this European Technical Assessment in other languages shall fully correspond to the original issued document and shall be identified as such.

Communication of this European Technical Assessment, including transmission by electronic means, shall be in full. However, partial reproduction may only be made with the written consent of the issuing Technical Assessment Body. Any partial reproduction shall be identified as such.

This European Technical Assessment may be withdrawn by the issuing Technical Assessment Body, in particular pursuant to information by the Commission in accordance with Article 25(3) of Regulation (EU) No 305/2011.

## Specific Part

### 1 Technical description of the product

The kit "HECO-VB screws as fasteners in wood-concrete composite slab" contains of the following components:

#### Base Materials

- Sawn timber (softwood and hardwood) according to EN 14081-1,
- Glued laminated timber according to EN 14080,
- Laminated veneer lumber according to EN 14374 and
- Cross laminated timber according to European Technical Assessments.

Dowel type fasteners for shear resistant connection between base materials and the concrete material

- HECO-VB screws, installed under an angle of  $\pm 45^\circ$  and/or  $90^\circ$  into the base material (timber members). Shape and tolerances of the HECO-VB screws are given in Annex 3.

#### Moulding

- In the case of concrete cast at the building site: Formwork, e.g. timber boards or wood based panel. This is an optional intermediate layer between the concrete and the timber. When the concrete slabs are prefabricated, no intermediate layer between timber and concrete is needed.
- Lateral moulding along the edges of the slab. This moulding has no function in the final product. No essential characteristics are assessed for the moulding.

#### Finalisation of wood-concrete composite slab kit

- Concrete slab cast on site or in a prefabricating plant and reinforced according to standards and regulations in force at the place of use.
- Concrete slab, according to EN 206-1 and national regulations either prefabricated or cast at the building site. The minimum concrete strength class is C20/25.
- The concrete slab is not part of the kit. No characteristics are assessed for the concrete slab.

Finished floor or ceiling covering as well as possible sound reducing courses are not part of the kit.

A principle structure of the wood-concrete composite slab kits is shown in Figure A.2.1 of Annex 2. The area of concrete is subjected to compression. The timber members usually run parallel or nearly parallel to each other.

The screws are made of case hardened steel and are corrosion protected with a zinc coating or brown patina. The geometry of the screws is shown in Annex 3.

This European Technical Assessment covers screws for composite members with a minimum concrete flange depth of 50 mm and a minimum depth of the timber member of 100 mm. The maximum concrete flange depth is 70 % of the timber member depth. Typical spans for the construction are up to 8 m with sawn softwood timber members, 10 m with LVL members and 14 m with glulam members.

## 2 Specification of the intended use in accordance with the applicable European Assessment Document

The performances given in Section 3 are only valid if the wood-concrete composite slab kit are used in compliance with the specifications and conditions given in Annex 1 to 5.

The provisions made in this European technical assessment are based on an assumed working life of HECO-VB screws for wood-concrete composite slab kits of 50 years. The indications given on the working life cannot be interpreted as a guarantee given by the producer, but are to be regarded only as a means for choosing the right products in relation to the expected economically reasonable working life of the works.

## 3 Performance of the product and references to the methods used for its assessment

### 3.1 Essential characteristics of the product

Table 1: Essential characteristics of the wood-concrete composite slab kit and methods and criteria for assessment of the performance of the product in relation to those essential characteristics

Essential characteristic	Assessment of characteristic
Mechanical resistance and stability (BWR 1) <sup>1)</sup>	
Mechanical resistance	Annex 4, Table 4.2
Dimensional stability	Annex 4, Table 4.2
Stiffness	Annex 4, Table 4.2
Safety in case of fire (BWR 2)	
Reaction to fire	Annex 4, Table 4.2
Hygiene, health and the environment (BWR 3)	
Water vapour permeability	Annex 4, Table 4.2
Safety and accessibility in use (BWR 4)	
Same as BWR 1	
Energy economy and heat retention (BWR 6)	
Thermal resistance	Annex 4, Table 4.2
Air permeability	no performance assessed
Thermal inertia	Annex 4, Table 4.2

<sup>1)</sup> This characteristic also relates to BWR 4.

Table 2: Essential characteristics of the base materials and methods and criteria for assessment of the performance of the product in relation to those essential characteristics

Essential characteristic	Assessment of characteristic
Mechanical resistance and stability (BWR 1) <sup>1)</sup>	
Mechanical resistance	Annex 4, Table 4.1
Dimensional stability	Annex 4, Table 4.2
Stiffness	Annex 4, Table 4.1
In service environment	Annex 4, Table 4.2
Safety in case of fire (BWR 2)	
Reaction to fire	Annex 4, Table 4.2
Safety and accessibility in use (BWR 4)	
Same as BWR 1	
Energy economy and heat retention (BWR 6)	
Thermal resistance	Annex 4, Table 4.2
Thermal inertia	Annex 4, Table 4.2

<sup>1)</sup> This characteristic also relates to BWR 4.

Table 3: Essential characteristics of the dowel type fasteners and methods and criteria for assessment of the performance of the product in relation to those essential characteristics

Essential characteristic	Assessment of characteristic
Mechanical resistance and stability (BWR 1) <sup>1)</sup>	
Material	Annex 2
Geometry	Annex 3
Mechanical strength	Annex 5, Table A.5.4
Mechanical stiffness	Annex 5, Table A.5.2
Corrosion protection	Annex 2
Shear resistance	Annex 5, Table A.5.3
Safety and accessibility in use (BWR 4)	
Same as BWR 1	

<sup>1)</sup> This characteristic also relates to BWR 4.

**4 Assessment and verification of constancy of performance (AVCP) system applied, with reference to its legal base**

In accordance with EAD No. 130090-00-0303 the applicable European legal act is: 2000/447/EC  
The system to be applied is: 1

**5 Technical details necessary for the implementation of the AVCP system, as provided for in the applicable EAD**

Technical details necessary for the implementation of the AVCP system are laid down in the control plan deposited with Deutsches Institut für Bautechnik.

Issued in Berlin on 12 August 2024 by Deutsches Institut für Bautechnik

Anja Dewitt  
Head of Section

*beglaubigt:*  
Deniz

## Annex 1

### A.1.1 Intended use, load and design

HECO-VB screws as fasteners in wood-concrete composite slab are intended to be used in structural composite members such as floor, roof, or wall constructions in service classes 1 and 2 as defined in EN 1995-1-1 subject to static or quasi static loading.

The concrete slab shall be arranged on top of the timber beams. The support of the wood concrete composite elements shall be carried out via the timber beams.

The wood-concrete composite slab kits are individually designed in order to meet the requirements for the works.

Wood-concrete composite slab kits including HECO-VB screws are manufactured and used according to an individual design made by a structural engineer responsible for the design of works on a case by case basis (floors) may function as directly load-bearing and structural bracing members.

### A.1.2 Manufacturing

HECO delivers the HECO-VB screws for use as components in wood-concrete composite slab kits in accordance with the provisions of this European Technical Assessment. The HECO-VB screws are manufactured in the factory in accordance with the provisions of this European Technical Assessment.

At the building site, additional components of the kit shall be assembled according to the design of each individual kit as specified by the designer of the works.

### A.1.3 Assembly and installation of the wood-concrete composite slab kit into the works

HECO-VB screws shall be installed on the basis of a specific structural design for each wood-concrete composite slab kit installation. The values of the load-bearing capacities to be used for design are given in Annex 5.

The design shall also take any aspects regarding installation of the wood-concrete composite slab kit components, as well as any temporary bracing and supporting into account. Wood-concrete composite slab kits shall be installed by appropriately qualified personnel, following the installation plan. Only screws without any defects are allowed to be used.

The manufacturer shall ensure that the parties involved will be informed of these provisions.

HECO-VB (HVB)	Annex 1
Specifications of intended use	

### Annex 2

#### Wood-concrete composite slab kits composed with HECO-VB screws

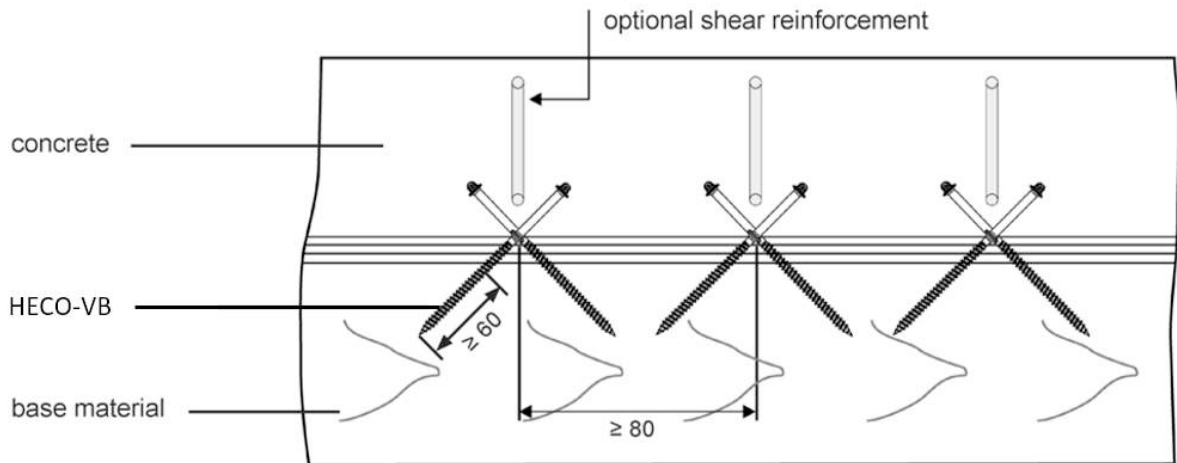

Figure A.2.1 Principle structure of wood-concrete composite slab kit with HECO-VB screws

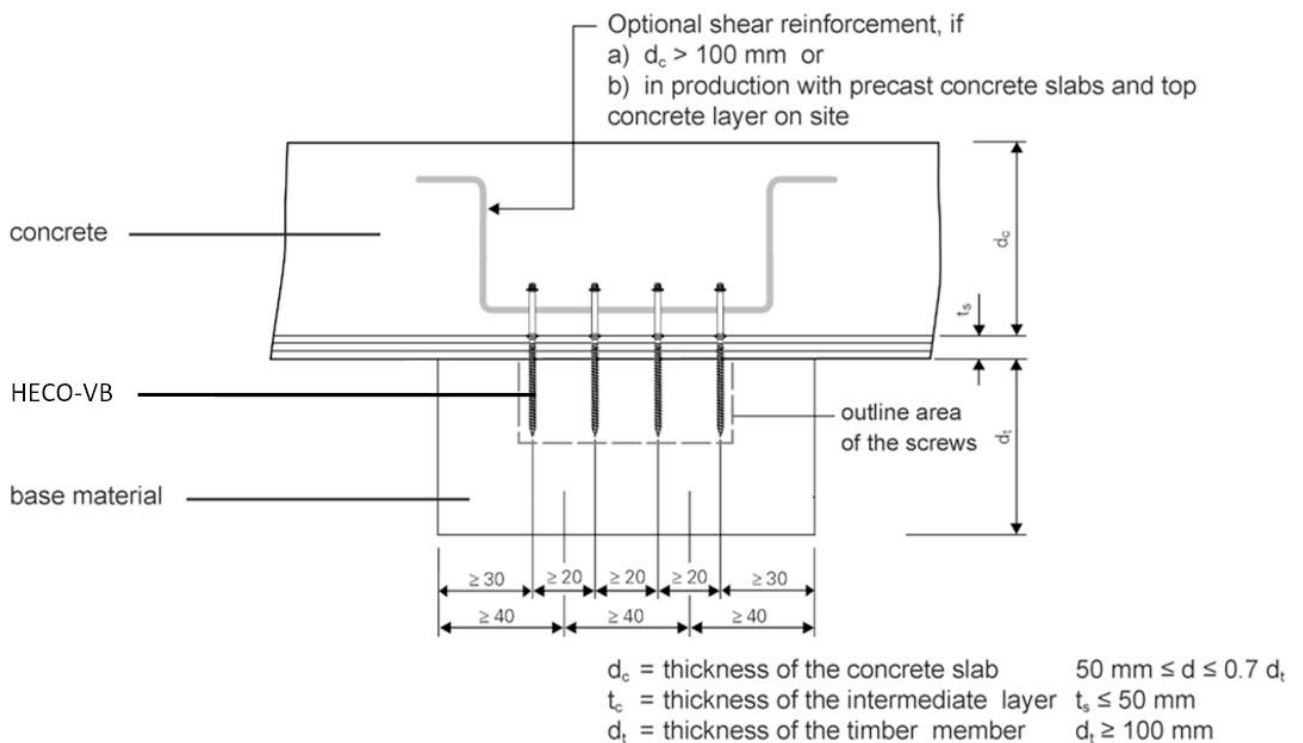

Figure A.2.2 Cross section through a composite member with HECO-VB screws

HECO-VB (HVB)

Structure of wood-concrete composite slab kit with HECO-VB screws

Annex 2  
page 1 of 2



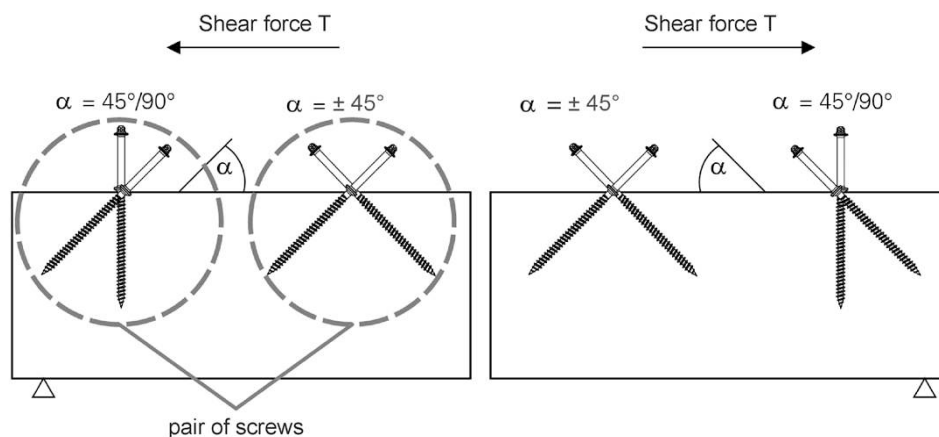

Figure A.2.3 Arrangement of HECO-VB screws in wood-concrete composite slabs kits

### HECO-VB screws

The screws are made of case hardened steel and are corrosion protected with a zinc coating or brown patina. The geometry of the screws are shown in Annex 3. A more exact description of the shape and tolerances of the screws can be found in the control plan. The composition of the screw materials is deposited with Deutsches Institut für Bautechnik.

The mechanical properties of HECO-VB screws and the coefficients for creep and duration of load factors for composite members are given in Annex 5.

Table A.2.1 Minimum spacing, end and edge distances for HECO-VB screws in mm

HECO-VB screw	$7.5 \times \lambda$
Spacing parallel to grain $a_1$	80
Spacing perpendicular to grain $a_2$	20
End distance (end of end-grain) $a_{3,c}$	80
Edge distance $a_{4,c}$	30

Structural elements of hardwood have to be pre-drilled for screws.

HECO-VB (HVB)

HECO-VB screws arrangement, properties and spacings

Annex 2  
page 2 of 2

### Annex 3 Drawings showing the properties of the HECO-VB screws

HECO-VB screws made of carbon steel

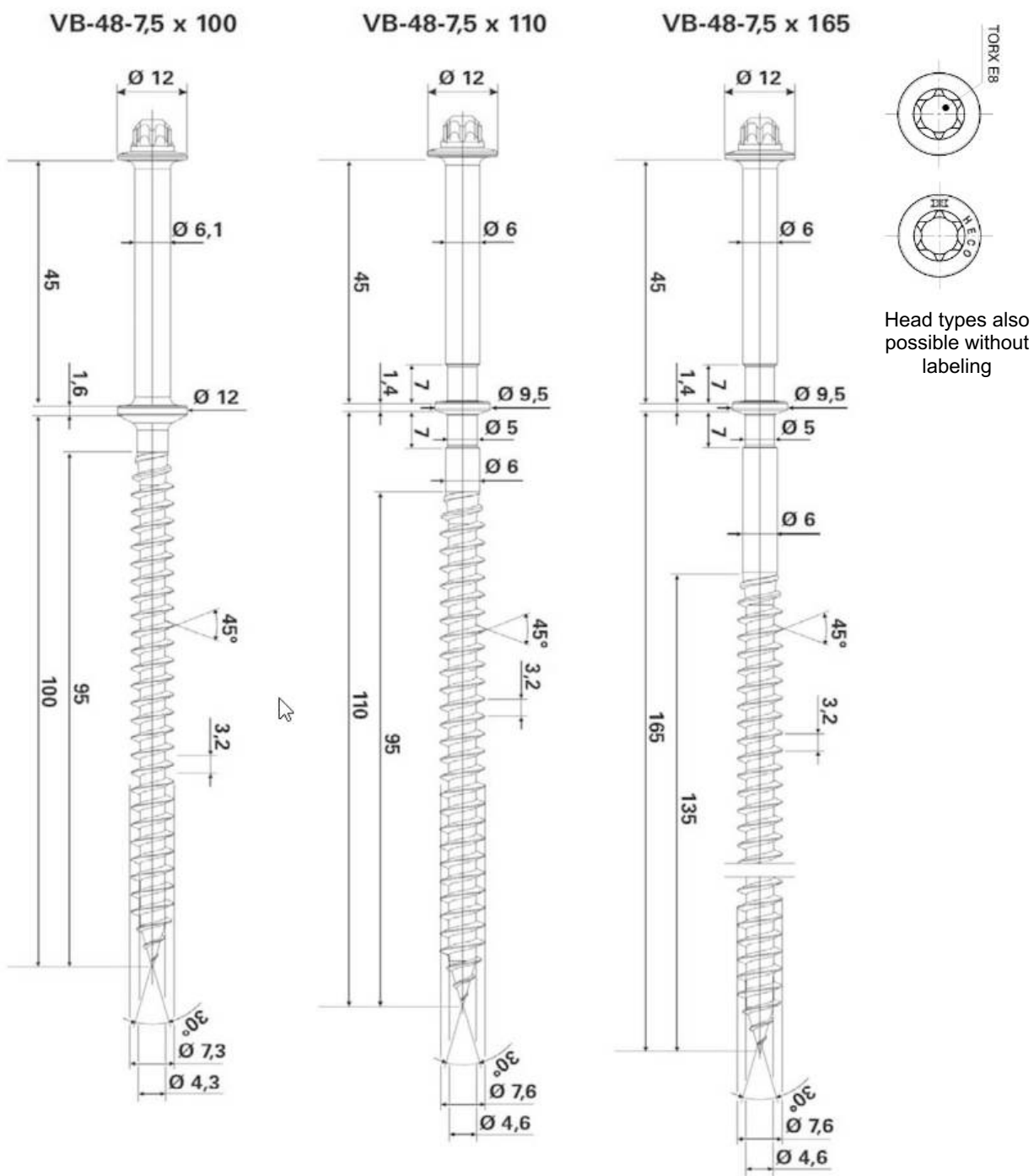

HECO-VB (HVB)

Geometry of the HECO-VB screws VB-48-7.5 x λ

Annex 3

## Annex 4

**Table A.4.1: Dimensions and specifications**

Characteristic	Dimension / Specification
<b>Wood-concrete composite slab kit</b>	
Width	acc. to manufacturer's specification
Length	Typical spans for the construction are up to 8 m with sawn softwood timber members, 10 m with LVL members and 14 m with glulam members, larger spans are also possible.
<b>Components</b>	
HECO-VB screws	See Annex 3
Concrete	≥ concrete strength class C20/25 acc. to EN 206-1
Timber members	Glued laminated timber acc. to EN 14080
	sawn softwood or hardwood acc. to EN 14081-1
	LVL according to EN 14374
	cross laminated timber according to European Technical Assessments
Formwork <sup>1)</sup>	e.g. timber boards or wood based panels

<sup>1)</sup> This is an optional intermediate layer between the concrete and the timber

HECO-VB (HVB)

Dimensions and specifications

Annex 4  
page 1 of 2

**Table A.4.2: Product characteristics of the wood-concrete composite slab kit**

BWR	Essential characteristic	Assessment	Class / Level / Value / Description
1	<b>Mechanical resistance and stability</b> <sup>1)</sup>		
	Mechanical resistance	EN 1995-1-1 and 1992-1-1, see Annex 5	
	Creep and duration of load	See Annex 5	
	Dimensional stability	Moisture content during use shall not change to such extent that adverse deformations can occur.	
	Stiffness (t = 0) Slip modulus $K_{ser}$	EAD 130090-00-0303	See Annex 5
	In-service environment	EN 1995-1-1	Service class 1 and 2
2	<b>Safety in case of fire</b>		
	<b>Reaction to fire</b>		
	sawn timber	Commission Decision 2003/593/EC	Euroclass D-s2, d0
	Glued laminated timber	Commission Decision 2005/610/EC	Euroclass D-s2, d0
	cross laminated timber	Commission Decision 2005/610/EC	Euroclass D-s2, d0
	LVL	Commission Decision 2017/2293/EC	Euroclass D-s2, d0
	plywood	Commission Decision 2003/593/EC	Euroclass D-s2, d0
	Steel members and concrete	EC Decision 96/603/EC	Euroclass A1
3	<b>Hygiene, health and the environment</b>		
	Vapour permeability $\mu$	acc. to EN ISO 10456 for the respective material	
4	<b>Safety and accessibility in use</b>		
	Same as BWR 1		
6	<b>Energy economy and heat retention</b>		
	Thermal resistance	acc. to EN ISO 10456 for the respective material	
	Air permeability	EN 12114	no performance assessed
	Thermal inertia	acc. to EN ISO 10456 for the respective material	
<sup>1)</sup> This characteristic also relates to BWR 4.			

HECO-VB (HVB)

Product characteristics of the wood-concrete composite slab kit

Annex 4  
page 2 of 2

## Annex 5 (informative)

### Static model and general information

Composite constructions with HECO-VB screws are to be designed taking into account the influence of the slip occurring in the joints. A method for the calculation of the load-bearing capacity and the deformation of mechanically jointed beams or columns is given in Annexes B and C of EN 1995-1-1.

Calculations should be carried out assuming a linear relationship between force and slip. Alternative methods for the calculation based on numerical models are also applicable.

The mechanical model describing the shear force transfer is shown in Figure A.5.

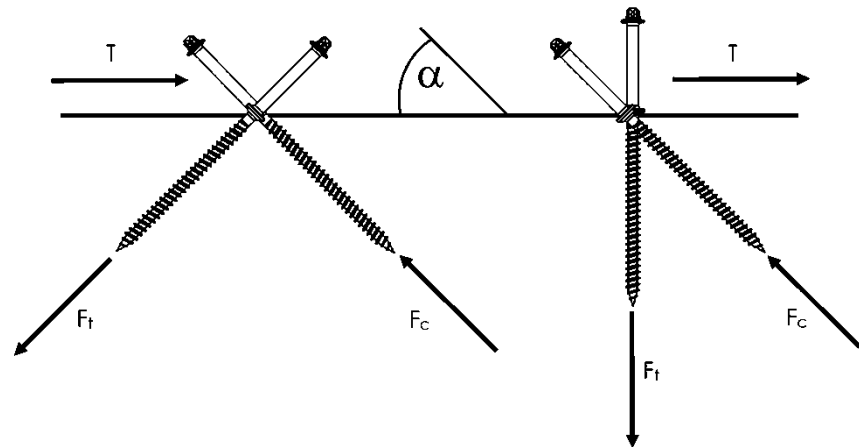

Figure A.5: Mechanical model according to truss analogy

A truss analogy is used. The threaded part of the screw in the timber is considered elastically founded parallel to the screw axis. The foundation in the concrete is considered infinitely stiff. An interlayer with the thickness  $t$  may be arranged between timber and concrete.

The shear force  $T$  parallel to the joint between timber and concrete is divided into a component parallel to the tensile screw axis and a component parallel to the compressive screw axis. Friction forces between timber and concrete are not considered. The tensile force  $F_t$  and the compressive force  $F_c$  follow the shear force  $T$  and the angle  $\alpha$ :

$$F_t = F_c = \frac{T}{\sqrt{2}} \quad \text{for screw arrangement } \pm 45^\circ$$

$$F_t = T \quad \text{for screw arrangement } 45^\circ/90^\circ$$

$$F_c = T \cdot \sqrt{2} \quad \text{for screw arrangement } 45^\circ/90^\circ$$

For calculation of internal forces the mean or nominal values of the elasticity and slip modulus shall be used.

The concrete slab shall be arranged on top of the timber beams. The support of the wood concrete composite elements shall be carried out via the timber beams.

HECO-VB (HVB)

Design considerations (informative)

Annex 5  
page 1 of 3

### Design of the wood-concrete composite slab kit

HECO-VB screws may be used in service class 1 and 2 according to EN 1995-1-1.

The design of the wood-concrete composite slab kit in the ultimate and the serviceability limit states shall take into account the influence of creep, concrete shrinkage and moisture changes. The verification of the limit states is to be performed both for the initial state ( $t = 0$ ) and the final state ( $t = \infty$ ).

The influence of creep and moisture changes may be taken into account by reducing the modulus of elasticity of the timber and concrete and the slip modulus to be used in calculations analogous with EN 1995-1-1. For the deformation factors  $k_{def}$  see Table A.5.1.

Table A.5.1 – Values of  $k_{def}$  for timber, concrete and HECO-VB screws

Material	Service class	
	1	2
Solid timber, EN 14081-1	0.6	2.0
Glued Laminated timber, EN 14080	0.6	2.0
LVL, EN 14374	0.6	2.0
Cross laminated timber, ETA	0.8	2.0
Concrete, EN 206-1	2.5	2.5
HECO-VB screw connection	0.6	4.0

For timber-concrete composite joints made with HECO-VB screws the slip modulus  $K_{ser}$  per pair of screws under service load parallel to the shear plane should be taken from Table A.5.2 with  $l_{ef}$  in mm.

Table A.5.2 – Values of  $K_{ser}$  for timber-concrete joints with HECO-VB screws

HECO-VB screw orientation $\alpha$ in °	$K_{ser}$ in N/mm
$\pm 45^\circ$	$240 \cdot l_{ef}$
$45^\circ/90^\circ$	$100 \cdot l_{ef}$

with

$l_{ef}$  is the penetration depth of the HECO-VB screw in the timber member in mm,  
for screw arrangement  $45^\circ/90^\circ$  is  $l_{ef}$  the penetration depth of the  $90^\circ$  screw

For timber-concrete composite joints made with HECO-VB screws the characteristic load bearing capacity per pair of screws  $F_{Rk}$  parallel to the shear plane shall be taken from Table A.5.3. with  $\rho_k$  in  $kg/m^3$  and  $l_{ef}$  in mm.

HECO-VB (HVB)	Annex 5 page 2 of 3
Design considerations (informative)	

Table A.5.3 – Values of  $F_{Rk}$  for timber-concrete-joints with HECO-VB screws

$F_{Rk}$ in N	
$F_{Rk} = k_{\alpha} \cdot \min \begin{cases} F_{ax,\alpha,Rk} \\ 13000 \end{cases}$	
where:	
$F_{Rk}$	is the characteristic load-carrying capacity per pair of HECO-VB screws in N;
$k_{\alpha}$	is a factor taking into account the screw arrangement; $k_{\alpha} = 1,414$ for $\alpha = \pm 45^{\circ}$ $k_{\alpha} = 1,0$ for $\alpha = 45^{\circ}/90^{\circ}$
$F_{ax,\alpha,Rk}$	is the characteristic withdrawal capacity in N;
	$F_{ax,\alpha,Rk} = 90 \cdot \ell_{ef} \cdot \left( \frac{\rho_k}{350} \right)^{0,8}$ for HECO-VB screws in softwood
	$F_{ax,\alpha,Rk} = 180 \cdot \ell_{ef} \cdot \left( \frac{\rho_k}{530} \right)^{0,8}$ for HECO-VB screws in pre-drilled hardwood
$\ell_{ef}$	is the penetration depth of the HECO-VB screws screw in the timber member in mm, for screw arrangement $45^{\circ}/90^{\circ}$ is $\ell_{ef}$ the penetration depth of the $90^{\circ}$ screw;
$\rho_k$	is the characteristic timber member density in $kg/m^3$ ;
$\alpha$	is the angle between screw axis and grain direction.

Table A.5.4 – Properties of HECO-VB screws

HECO-VB screw	VB-48-7,5x100	VB-48-7,5x110	VB-48-7,5x165
Tensile strength $f_{tens,k}$ [kN]	16	17	17
Torsional strength $R_{tor,k}$ [Nm]	16	18	18

Apart from the design of the composite member, the load-carrying-capacity of the concrete layer spanning between the timber beams and the shear capacity of the timber member in the perimeter area around the screws should be checked.

HECO-VB (HVB)	Annex 5 page 3 of 3
Design considerations (informative)	

## Annex 6

### Reference documents

EAD 130090-00-0303, European Assessment Document for "Wood-Concrete composite slab with dowel-type fasteners", Edition December 2017

EN 14081-1:2016 Timber structures – Strength graded structural timber with rectangular cross section – Part 1: General requirements

EN 14080:2013, Timber structures - Glued laminated timber and glued solid timber - Requirements

EN 14374-2005: Timber structures - Structural laminated veneer lumber – Requirements

EN 206-1:2021-06: Concrete- Part 1: Specification, performance, production and conformity

EN 338:2016 Structural timber - Strength classes

EN 1995-1-1:2010 + A2:2014, Eurocode 5: Design of timber structures - Part 1-1: General - Common rules and rules for buildings

EN 1992-1-1:2011, Eurocode 2 - Design of concrete structures - Part 1-1: General rules and rules for buildings

EN ISO 10456:2010, Building materials and products – Hygrothermal properties – Tabulated design values and procedures for determining declared and design thermal values

HECO-VB (HVB)	Annex 6
Reference documents	