

Public-law institution jointly founded by the federal states and the Federation

European Technical Assessment Body
for construction products



European Technical Assessment

ETA-08/0099
of 9 February 2026

English translation prepared by DIBt - Original version in German language

General Part

Technical Assessment Body issuing the European Technical Assessment:

Deutsches Institut für Bautechnik

Trade name of the construction product

Glas Marte SG

Product family
to which the construction product belongs

SG-facade
Structural Sealant Glazing System - Type I and II

Manufacturer

Glas Marte GmbH
Brachsenweg 39
6900 Bregenz
ÖSTERREICH

Manufacturing plant

Glas Marte GmbH
Brachsenweg 39
6900 Bregenz
ÖSTERREICH

This European Technical Assessment
contains

22 pages including 15 annexes which form an integral
part of this assessment

This European Technical Assessment is
issued in accordance with Article 95(4) of
Regulation (EU) No 2024/3110, on the basis of

EAD 090010-00-0404

This version replaces

ETA-08/0099 issued on 17 January 2018

The European Technical Assessment is issued by the Technical Assessment Body in its official language. Translations of this European Technical Assessment in other languages shall fully correspond to the original issued document and shall be identified as such.

Communication of this European Technical Assessment, including transmission by electronic means, shall be in full. However, partial reproduction may only be made with the written consent of the issuing Technical Assessment Body. Any partial reproduction shall be identified as such.

This European Technical Assessment may be withdrawn by the issuing Technical Assessment Body, in particular pursuant to information by the Commission in accordance with Article 36(3) of Regulation (EU) No 2024/3110.

Specific Part

1 Technical description of the product

The object of this European Technical Assessment is the structural sealant glazing system "Glas Marte SG" manufactured by the company Glas Marte GmbH in Bregenz, Austria.

The structural sealant glazing system "Glas Marte SG" consists of insulating glass, single glass or non-transparent thermally insulated panel with a surrounding frame. The glass panes are bonded in the factory on all edges four sided with an aluminium frame to elements, which are mechanically fastened to the substructure on site.

The infill elements are bonded with a structural silicone sealant to the support frame (Annex 1). In the case of the insulating glass the edge seal of these elements is also load bearing.

At the construction site, the infill elements are mechanically fastened to the structure with clamps and the joint closed with backer rod and weather sealing.

The glass dead load is supported.

In addition there are retaining devices to reduce danger in case of bond failure (EAD 090010-00-0404, Type I and II).

2 Specification of the intended use in accordance with the applicable European Assessment Document EAD 090010-00-0404

The performances given in Section 3 are only valid if the elements for "Glas Marte SG" are used in compliance with the specifications and conditions given in the Annexes A to D.

The infill elements "Glas Marte SG" are installed in external walls. The application is suitable also for structures with an angle of inclination to vertical up to 10° in direction to the substructure.

The infill elements may be installed as horizontal respectively overhead glazing at inclinations with respect to the horizontal ranging from 7° to 90°.

For the use in structures the following types are differentiated in accordance with EAD 090010-00-0404:

Type I: Mechanical transfer of the self-weight of the facade element to the sealant-support frame and thence to the structure. The structural sealant transfers all other actions. Devices are used to reduce danger in the event of bond failure.

Type II: Mechanical transfer of the self-weight of the facade element to the sealant-support frames and thence to the structure. The structural sealant transfers all other actions and no devices are used to reduce danger in the event of bond failure.

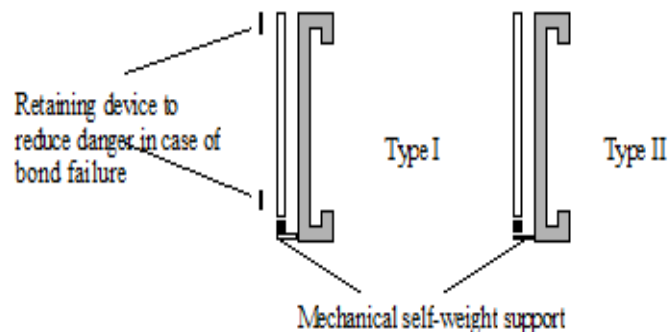

Figure 1: Schematic examples of types I and II

The verifications and assessment methods on which this European Technical Assessment is based lead to the assumption of a working life of "Glas Marte SG" of at least 25 years. The indications given on the working life cannot be interpreted as a guarantee given by the producer, but are to be regarded only as a means for choosing the right products in relation to the expected economically reasonable working life of the works.

3 Performance of the product and references to the methods used for its assessment

3.1 Mechanical resistance and stability (BWR 1)

Essential characteristic	Performance
Characteristics of the different glass products (characteristic bending strength, coating)	See Annex A
Use scenario for the heat soaking process	Use scenario 1a/1b; see Annex A
Use scenario for the compound effect of laminated safety glass	Use scenario 2a/2b; see Annex A
Structural bonding: Substrates and adhesive	See Annex B
Mechanically fixed glazing support, retaining devices and anchorage to the substructure - Load-bearing capacities	See Annex C

3.2 Safety in case of fire (BWR 2)

Essential characteristic	Performance
Reaction to fire of single glass panes and metal components in accordance with the provisions of EC Decision 1996/582/EC	A 1

4 Assessment and verification of constancy of performance (AVCP) system applied, with reference to its legal base

In accordance with EAD 090010-00-0404 the applicable European legal act is: 1996/582/EC¹.

The systems to be applied are:

- System 1 for Type II according to 2.1 Figure 1
- System 2+ for Type I according to 2.1 Figure 1

In addition the European legal act is: 2003/656/EC² is valid for the reaction to fire of products according to this European Assessment Document.

The systems to be applied are:

- System 1, 3, 4

¹ Official Journal of the European Communities no L 254/62 of 08.10.1996

² Official Journal of the European Communities no L 231/15 of 17.09.2003

5 Technical details necessary for the implementation of the AVCP system, as provided for in the applicable European Assessment Document

Technical details necessary for the implementation of the AVCP system are laid down in the control plan deposited with Deutsches Institut für Bautechnik.

Annex A Characteristics of the different glass products

Annex B Structural bonding and sealing

Annex C Characteristics and load-bearing capacities of the glazing supports, retaining devices and anchorage to the substructure

Annex D Details for structural design calculation and installation

Issued in Berlin on 9 February 2026 by Deutsches Institut für Bautechnik

Dipl.-Ing. Andreas Kummerow
Head of Department

beglaubigt:
Schult

Annex A

Characteristics of the different glass products

Glass products

A double or triple glass unit or a single glass pane is installed for "Glas Marte SG". Depending on the use scenario given below and the requirements due to the designing results for the existing actions at the place of installation the suitable glass products are chosen and declared.

The basic glass type of all glass products is float glass according to EN 572-9³ made of soda lime silicate glass. Dependent on the appropriate use scenario the following products are suitable: thermally toughened soda lime silicate safety glass according to EN 12150-2, coated glass according to EN 1096-4⁴, heat soaked thermally toughened soda lime silicate safety glass according to EN 14179-2⁵, heat soaked thermally toughened soda lime silicate safety glass according to EN 14179-2 but with deviating requirements concerning the duration of the holding phase of four hours and the involvement of a notified body for controlling the heat-soaking process, heat strengthened soda lime silicate glass (TVG) according to EN 1863-2⁶ and laminated safety glass (VSG) according to EN 14449⁷ with an interlayer made of polyvinyl butyral (PVB) is used. The PVB-interlayer has to feature the following properties for tear strength > 20 N/mm² and for elongation at rupture > 250 %.

The characteristic bending strength of the glass panes according to EN 1288-3⁸ is given in the "Declaration of Performance" as basis for the designing respectively to ensure that they will safely transmit the wind load to the support frame via the structural sealant.

The glass panes coated or entirely or partially enamelled may only be used, if the adhesive behaviour of the surfaces has been verified according to EAD 090010-00-0404 with the adhesive DOWSIL 3362⁹ according to ETA-03/0003 or DOWSIL 993 according to ETA-01/0005. In the table given below coated glass products are listed which are suitable for bonding with DOWSIL 993. If other enamellings or coatings of the glass panes are foreseen the bonded area shall be left out from this enamelling or coating. The coating is given in the "Declaration of Performance".

In the case of overhead glazing the lower pane of the insulating glass unit is made of laminated safety glass.

In the insulated glass unit the butyl sealing strip "Butylver" of Fa. Fenzi, Tribiano (Milano), Italy, is used. The compatibility between the named butyl and DOWSIL 3362 is verified.

Furthermore it shall be observed that when using the coated glass according to EN 1096-4⁴ as laminated safety glass the coated glass surface may not be oriented towards the PVB-interlayer.

The insulated glass unit shall comply with the regulations for insulating glass units as per EN 1279-5¹⁰.

3	EN 572-9:2004	Glass in building – Basic soda lime silicate glass products – Part 9: Evaluation of conformity/Product standard
4	EN 1096-4:2018	Glass in building - Coated glass - Part 4: Evaluation of conformity/Product standard
5	EN 14179-2:2005	Glass in building - Heat soaked thermally toughened soda lime silicate safety glass - Part 2: Evaluation of conformity/Product standard
6	EN 1863-2:2004	Glass in building – Heat strengthened soda soda lime silicate glass – Part 2: Evaluation of conformity/Product standard
7	EN 14449:2005	Glass in building – Laminated glass and laminated safety glass – Evaluation of conformity/Product standard
8	EN 1288-3:2000	Glass in building - Determination of the bending strength of glass - Part 3: Test with specimen supported at two points (four point bending)
9	DOWSIL 3362, DOWSIL 993, DOWSIL 791 (new product names) are equivalent to DC 3362, DC 993, DC 791	
10	EN 1279-5	Glass in building - Insulating glass units – Part 5: Evaluation of conformity

Use scenarios:

- 1a Use of monolithic exterior panes for the insulated glass unit (e.g. in Germany at installation height of more than 4 m): Heat-soaked thermally toughened soda lime silicate safety glass is required according to EN 14179-1¹¹ but with duration of the holding phase of four hours and involving a notified body for controlling the heat-soaking process.
- 1b Use of monolithic exterior panes for the insulated glass unit (e.g. in Germany at installation height of less than 4 m): Thermally toughened soda lime silicate safety glass according to EN 12150-1¹², -2¹³ or according to EN 14179-1¹¹, -2⁵.
- 2a Use of laminated safety glass for the exterior or interior pane of the insulated glass unit according to EN 14449⁷ with PVB-interlayer; Compound effects are not respected.
- 2b Use of laminated safety glass for the exterior or interior pane of the insulated glass unit according to EN 14449⁷; Compound effects are respected regarding $G = 0.4 \text{ N/mm}^2$.

Coated glass products, suitable for structural sealant DOWSIL 993 without removing the coating from the panel edges

Manufacturer	Name of the product
Ferro AG, Frankfurt a.M., Deutschland	Glaskeramische Farbe, Kollektion 34
	Glaskeramische Farbe, Kollektion 140
Glas Trösch AG, Schweiz	SILVERSTAR Sunstop T Silber 20
	SILVERSTAR Sunstop T Silber 20 mit Siebdruck *
	SILVERSTAR Sunstop T Blau 30
	SILVERSTAR Sunstop T Blau 50
	SILVERSTAR Sunstop T Neutral 50
Glaverbel, Belgien	Stopsol Supersilver klar
Guardian, Europe S.A.R.L.	SunGuard Solar Light Blue 52
	SunGuard Solar HP Neutral 41/33 *
	SunGuard Solar HP Neutral 52/41 *
	SunGuard Solar Light Blue 62/52 *
	SunGuard Solar HP Silver 43/31 *
	SunGuard Solar HP Royal Blue 38/31 *
	SunGuard Solar Neutral 67
	SunGuard Solar Silver Grey 32
	SunGuard Solar Silver 20
	SunGuard Solar Royal Blue 20 *
SunGuard Solar Silver 08	

¹¹ EN 14179-1: 2016 Glass in building - Heat soaked thermally toughened soda lime silicate safety glass – Part 1: Definition and description

¹² EN 12150-1:2015 Glass in building – Thermally toughened soda lime silicate glass – Part 1: Definition and description

¹³ EN 12150-2:2004 Glass in building .Thermally toughened soda lime silicate safety glass Part 2: Evaluation of conformity/Product standard

Manufacturer	Name of the product
Saint Gobain Glas, Belgien	Cool-Lite ST 108
	Cool-Lite ST 120
	Cool-Lite ST 150
	Cool-Lite SS 108
	Cool-Lite STB 120
	Antelio clear
	Antelio silver

* These coatings may be enamelled by Ferro, collection 140. It doesn't apply for the colour transparent and metallic of collection 140.

Annex B

Structural bonding and sealing

Bonding profiles for insulating glass

The bonding profiles AR1 and AR2 are used in combination with insulating glass and the given adhesives.

Table 1: Bonding profiles for insulating glass

Product	Art. No.	Surface condition	Adhesives that may be used
Bonding profiles made of EN AW 6060 aluminium as per EN 573-3 ¹⁴ , state T66 as per EN 755-2 ¹⁵	AR1 AR2	Anodised aluminium*: colours C35 black and natural colour A6/C0* by Piesslinger GmbH, Molln, Austria, colours E6/EV1 and E6/C35 by Eloxalwerk Ehingen, Krämer + Eckert GmbH & Co. KG, Ehingen, Germany	DOWSIL 993
		Glass	DOWSIL 3362
* The anodising process is to be conform to the specifications described in the test reports respectively deposited in Deutsches Institut für Bautechnik.			

Bonding profiles for monolithic glazing

Monolithic glazing used for "Glas Marte SG" is to be produced of heat soaked thermally toughened soda lime silicate safety glass according to EN 14179-2⁵ or heat soaked thermally toughened soda lime silicate safety glass according EN 14179-2⁵ but with deviating requirements concerning the duration of the holding phase of four hours and involving a notified body for controlling the heat-soaking process with respect to the appropriate use scenario.

The adhesives specified below may be used for sealing the profiles, when the surface structure corresponds to the specifications in Table 2.

Table 2: Bonding profiles for monolithic glazing

Product	Art. No.	Surface condition	Adhesives that may be used
Bonding profiles made of EN AW 6060 aluminium as per EN 573-3 ¹⁴ state T66 as per EN 755-2 ¹⁵	AR1 AR2	Anodised aluminium*: colours C35 black and natural colour A6/C0* by Piesslinger GmbH, Molln, Austria, colours E6/EV1 and E6/C35 by Eloxalwerk Ehingen, Krämer + Eckert GmbH & Co. KG, Ehingen, Germany	DOWSIL 993
* The anodising process is to conform to the specifications described in the test reports respectively deposited in Deutsches Institut für Bautechnik.			

Adhesives

For the structural sealant of the glass panes with the structural sealant support frame, the two-component silicone sealant DOWSIL 993 is to be used (ETA-01/0005). The base and catalyst are to be mixed in a weight ratio of 10:1 or volume ratio of 7:1.

- ¹⁴ EN 573-3:2013 Aluminium and aluminium alloys - Chemical composition and form of wrought products - Part 3: Chemical composition and form of products
- ¹⁵ EN 755-2:2016 Aluminium and aluminium alloys - Extruded rod/bar, tube and profiles - Part 2: Mechanical properties

The silicone sealant DOWSIL 3362 (ETA-03/0003) is used for the structural sealing of the edge seal of the insulating glazing and if applicable for the non-transparent panel.

Table 3: Structural sealants

Structural sealant	Manufacturer	Associated ETA	Surfaces tested
DOWSIL 993	DOW Europe GmbH	ETA-01/0005	For coated glass Annex A shall be observed. For anodised aluminium Table 1 and 2 and Annex A shall be observed.
DOWSIL 3362	DOW Europe GmbH	ETA-03/0003	Edge seal: For coated glass Annex A shall be observed.

Details for the bonding process

The bonding of the infill elements is only done in the manufacturing plant of Glas Marte GmbH in Bregenz.

The surfaces to be sealed may only be prepared in conformity with the manufacturing directives given by the sealant manufacturer. Bubbles, holes or inclusions in the structural sealant are not permissible.

Only compatible materials may be installed adjacent to the structural sealant, and this compatibility is to be proven in the assessment procedure.

For the use as horizontal respectively overhead glazing the structural sealant of the infill elements shall be positioned in such a way that it is not constantly subjected to tensile forces.

Distance profile and weather sealing

A distance profile Thermalbond V2100 of the company Norton / St. Gobain is to be placed between the interior glass pane of the insulating glazing and the structural sealant support frame.

The weather sealing consists of the closed-cell polyethylene (PE) as backer rod and DOWSIL 791 as sealing material. The joint width is 14 mm.

The grooved seam in the base and eaves point of the facade is ventilated externally.

Annex C

Characteristics and load-bearing capacities of the glazing supports, retaining devices and anchorage to the substructure

Glazing supports (see Annex 1)

The self-weight of the glass panes is supported mechanically. It depends on the substructure and the glass weight which kind of mechanical self-weight support is used and inserted in the screw channel of the transom and screwed or welded together (Annex 1). The mechanical self-weight supports of the respective substructure system suppliers shall be verified. At least 1/2 of the thickness of the exterior glass pane is supported. Setting blocks are used to prevent contact between steel and glass. For this the standard setting block made of polypropylene of the company Gluske BKV GmbH is used.

Wind retaining devices (emergency retainers) (see Annexes 3, 5, 6, 7)

For the loading case when the sealant fails, the horizontal wind suction loads are absorbed and passed on by emergency retainers. The necessity to use such emergency retainers is regulated by the respective Member States.

Steel wire structure MSR 40

To safeguard the glazing in case of failure of the structural bond, safety devices in the form of a spring steel wire with a diameter of 1.5 mm is inserted in quadrant shaped grooves both in the exterior thermally toughened soda lime silicate safety glass or heat soaked thermally toughened soda lime silicate safety glass panel and in the structural sealant support frame. The spring steel wire consists of stainless steel, Material No. 1.4310, in accordance with EN 10270-3¹⁶, corrosion resistance class "moderate"¹⁷. This safety element engages in the countersink of all four corners of the exterior panel (Annex 3). The countersink is bored before the thermally toughening. The surface of the countersink shall not be sharp-edged, the quality shall correspond to a roughly ground surface. The contact between glass and wire is prevented by a silicone intermediate layer DOWSIL 791. For the countersink it is necessary that the outer pane is made of thermally toughened soda lime silicate safety glass or heat soaked thermally toughened soda lime silicate safety glass with a minimum thickness of 8 mm.

The steel wire structure may be used for monolithic panes, for double insulated glazing as well as for triplex insulated glazing.

The panes are held in the corners by a total of 4 safety elements (wire structures). The load capacity of one element is 1.1 kN. This allows for a 1.1-fold safety level. The maximum loadable actions from wind suction for one pane amounts to 4.4 kN.

Mechanical safety devices MSR SG-K

Alternatively to the steel wire structure according to Annex 3 safety-clamps to be used in case of failure of the structural bond are applied according to Annex 5 to 7. The safety-clamp with a length of 150 mm consists of a U-shaped powder-coated aluminium sheet jointing the exterior pane mechanically with the adapter profile. The side length of the safety clamp shall be adapted to the actual thickness of the element. There is a grinding along the whole glass edge of the exterior pane to insert the safety-clamps. The thickness of the exterior pane is at least 8 mm. The exterior pane is made of heat soaked thermally toughened soda lime silicate safety glass. Further particulars to the material of the safety clamps, their geometrical data and to the manufacturing of the grinding are deposited with Deutsches Institut für Bautechnik.

¹⁶ EN 10270-3:2011 Steel wire for mechanical springs – Part 3: Stainless spring steel wire

¹⁷ National technical approval of DIBt Z-30.3-6 for components and fasteners made of stainless steel

The line shaped safety clamps shall be capable in the case of bond failure of temporarily guaranteeing the stability of the system elements and, in particular, of bearing the wind suction forces. The load capacity of each safety clamp is 1.1 kN. This allows for a 1.1-fold safety level. The number of safety clamps as well as the distance between the safety clamps shall be determined from the wind suction load. The distance between the safety clamps shall not exceed 600 mm. The distance to the corner of the glass pane shall be 300 mm (Annex 5 to 7).

According to the outcome of the calculations the safety clamps are situated normally at the long edges of the pane, in case of small panes at all four edges.

Anchorage to the substructure (Annex 2)

In the factory the glass panes and the structural sealant support frame are bonded to elements which are connected to the substructure with clamps.

The clamps are made of stainless steel, Material No. 1.4301, in accordance with EN 10088¹⁸, strength class S235. The tensile force per clamp (design value for structural resistance) with the geometrical data according to Annex 3 is $F_d = 0.35$ kN.

The clamps are connected to the substructure with bolts. A centric load transfer has to be assured. The fastening of the clamp to the substructure has to be within the centre of gravity of the sealant. Aluminium, steel or wood profiles may be used as a substructure (Annex 2).

¹⁸ EN 10088-2:2005

Stainless steels - Part 2: Technical delivery conditions for sheet/plate and strip of corrosion resisting steels for general purposes

Annex D

Details for structural design calculation and installation

General aspects

The verification of durability is part of testing the essential characteristics. Durability is only ensured if the specifications for the intended use according to the following requirements and provisions are taken into account.

For the structural design calculation the design codes of the Member State, in which the infill elements will be used, shall be respected. To this the use scenarios according to Annex A shall be part of the "Declaration of Performance".

For choosing the appropriate glass panes and all mechanical devices see Annexes A to D.

The self-weight of the glazing and the wind loads shall be carried by the sub-structure. This shall be verified by calculation.

The widths of the joints shall be determined in such a way to avoid glass to glass or glass to metal contact.

The infill elements shall be fixed to the supporting structure according to the processing guidelines of the company Glas Marte GmbH such that no restraints may occur in the elements. The installation shall be performed by experts only, which have been trained for these works by the company Glas Marte GmbH.

The manufacturer shall take suitable precautions for packaging, transport and storage to prevent the application of unacceptable loads to the structural bonding, for example by providing suitable racks and to prevent from exposure to water, solar radiation or significant changes of temperature, by protecting with covers.

The cleaning of the façade may only be performed by using water with the addition of not more than 1 % surface-active agents without any other chemical additives and/or any aggressive cleaning methods (e.g. blast-cleaning with steam pressure).

Details for structural design calculation

1 Actions

For the stability of the elements and their anchorage to the structure a structural design calculation is needed. Particular consideration shall be given to:

- self-weight,
- wind,
- temperature and
- climatic conditions.

In the context of issuing this ETA no impact test was performed.

2 Verification of the structural bond

It shall be verified that the structural bond, under the actions is not exposed to any stress exceeding the specifications of ETA-01/0005 or ETA 03/0003 respectively.

The design of the structural bonds – between the infill element and the structural sealant support frame and the structural edge seal – has to be carried out in accordance with the regulations in the Member State in which the elements will be used. The Member State may refer to design recommendations of ETAG 002-1.

3 Verification of the glass panes

The stability of the exterior pane, where it is born exclusively by the wire structure, i.e. in the event of complete bond failure, and no load coupling between the exterior and interior pane, shall be demonstrated, safety factor 1,1. In particular for the safety devices MSR SG-K the verification shall demonstrate that the chord shortening of the exterior pane does not lead to slippage of the facade element under the wind suction load.

4 Verification of the mechanical safeguard due to the steel wire structure MSR 40

In the case of bond failure, the steel wire structure in accordance with Annex 3 shall be capable of temporarily guaranteeing the stability of the system elements and, in particular, of bearing the wind suction forces. The panes are held in the corners by a total of 4 safety elements (wire structures). For the load capacity see Annex C.

5 Verification of the mechanical safeguard due to the safety devices MSR SG-K

The line shaped safety clamps according to Annex 5 to 7 shall be capable in the case of bond failure of temporarily guaranteeing the stability of the system elements and, in particular, of bearing the wind suction forces. For the load capacity see Annex C.

According to the outcome of the calculations the safety clamps are situated normally at the long edges of the pane, in case of small panes at all four edges.

6 Deflection

The deflection of the frame profiles in the range of the pane edge shall not exceed $1/300$ of the relevant pane edge length, but for pane edges of the insulating glass it shall not exceed 15 mm. The deflection in the centre of the glass pane may not exceed $1/100$ of the smallest span of the plane in the case of service load.

7 Fixing

The number of clamps for fastening the elements to the supporting structure shall be calculated. The bolts are not the subject of this ETA.

Details for installation

The use of the infill elements for the stiffening of other building elements or as safety barrier to prevent from falling to a lower level is not covered by this ETA.

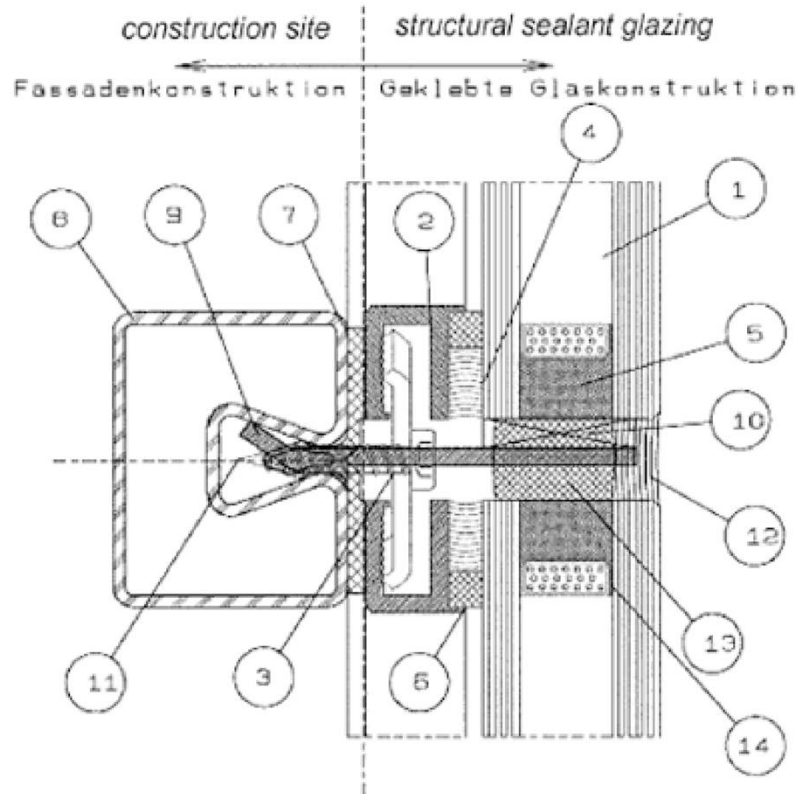

1. insulating glass
2. structural sealant support frame
3. clamp
4. structural silicone sealant DC 993
5. structural silicone sealant DC 3362
6. structural glazing spacer Thermalbond V 2100
7. gasket
8. substructure
9. mechanical self-weight support
10. standard-setting block of polypropylene
11. bolt
12. weather sealing
13. backer rod (PE)
14. butyl strip

Glas Marte SG

Annex 1

Definition of the system

Example with substructure in aluminium system

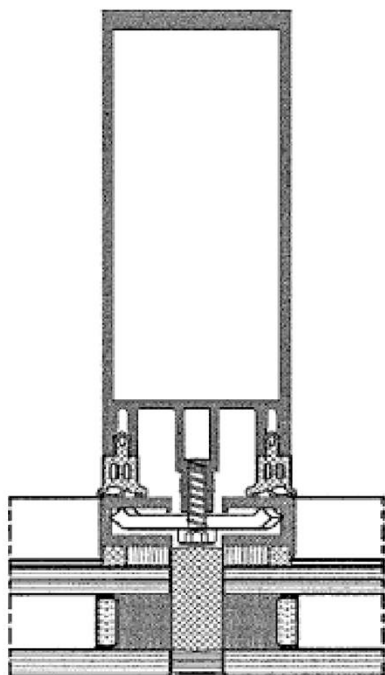

Example with substructure in steel combined with screw channel profil in aluminium

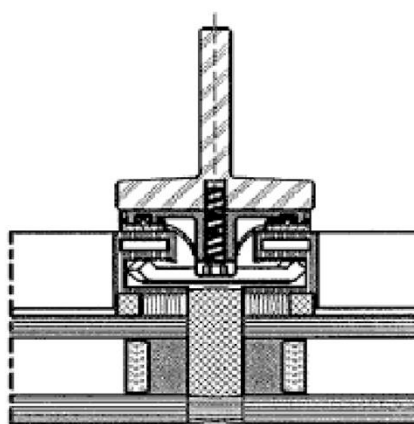

Example with substructure in wood

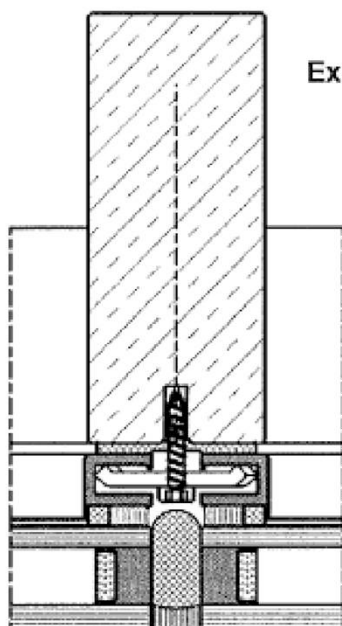

Glas Marte SG

Examples for substructures

Annex 2

Steel wire structure as safety element

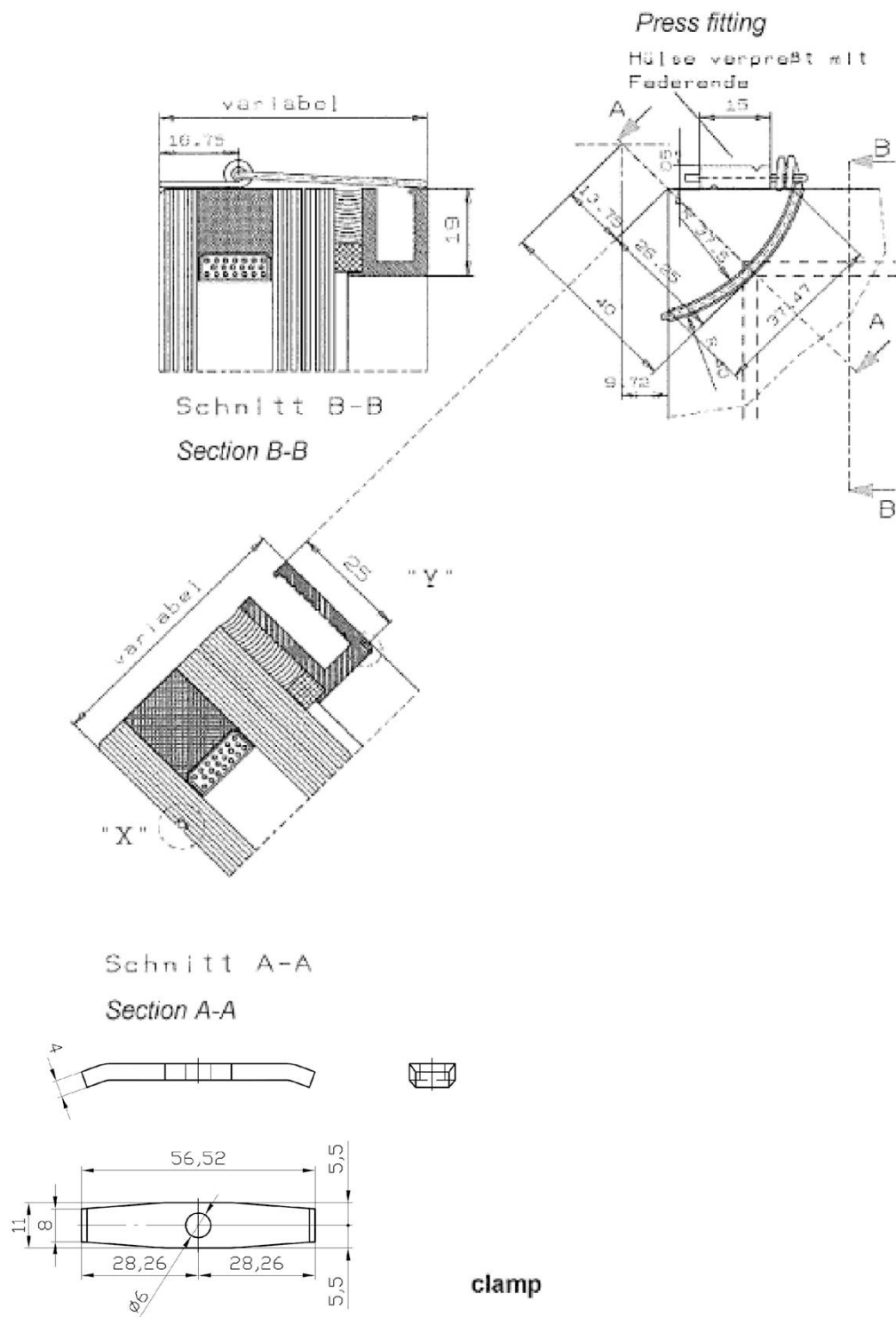

Glas Marte SG

Retaining devices

Annex 3

Support Frame AR1:

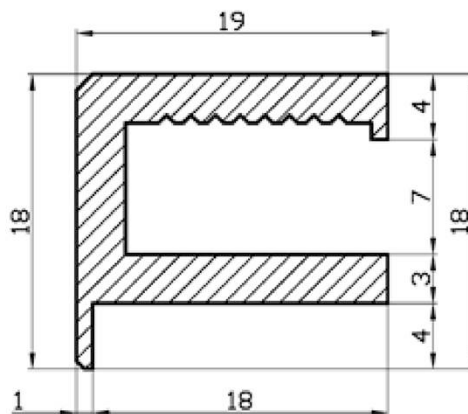

Material: AlMgSi 0,5 F22 - EN AW6060T66

Surface: Anodised

Support Frame AR2:

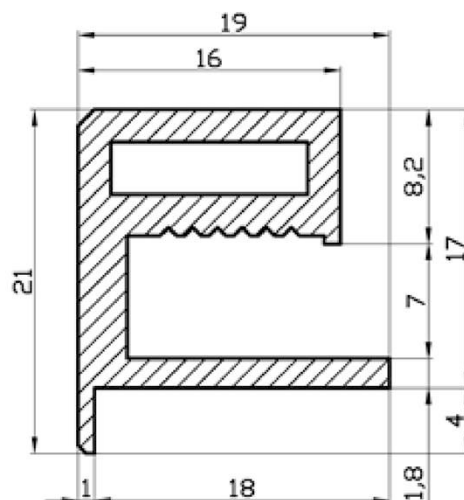

Material: AlMgSi 0,5 F22 - EN AW6060T66

Surface: Anodised

Glas Marte SG

Cross section support frame

Annex 4

Support Frame AR1:

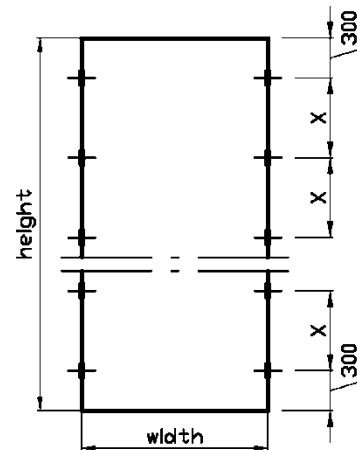
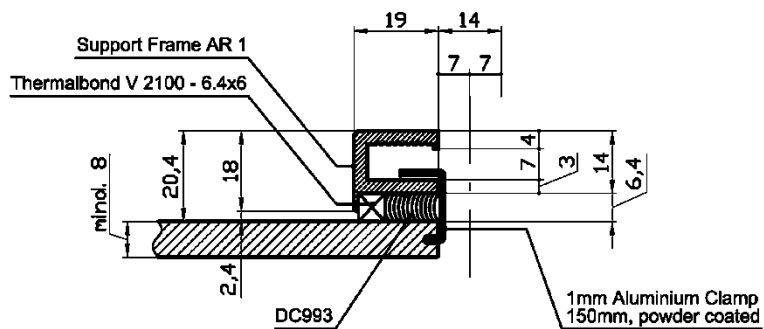

x = calculative detamination

Support Frame AR2:

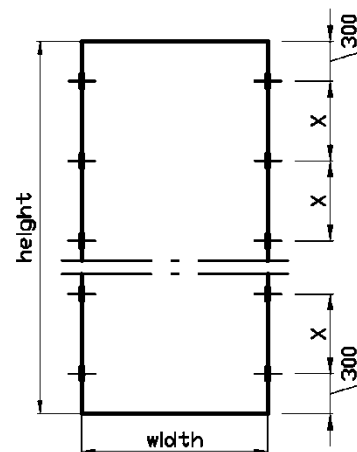
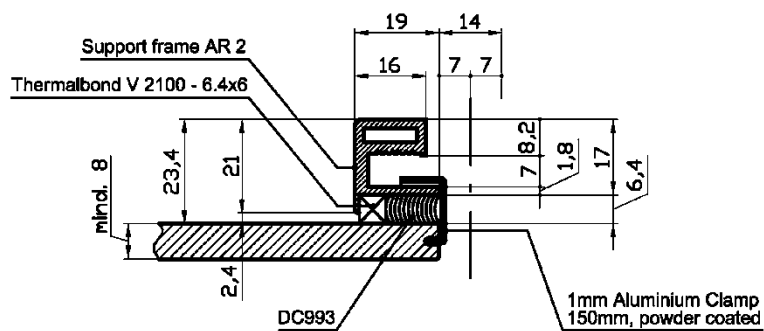

x = calculative detamination

Glas Marte SG

Support frames with retaining devices MSR SG-K – monolithic glazing

Annex 5

Support Frame AR1:

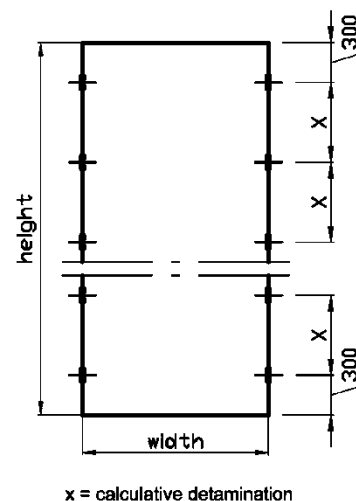
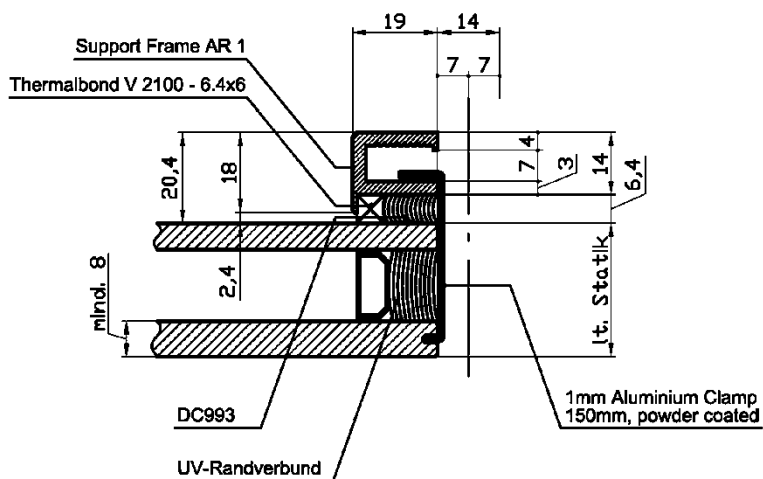

Support Frame AR2:

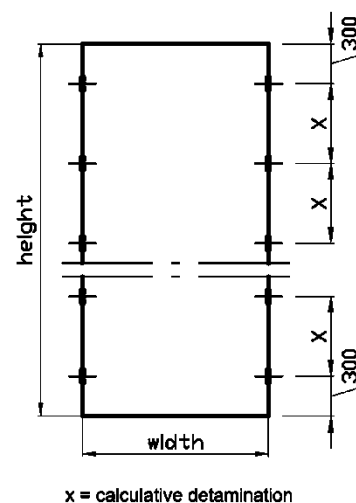
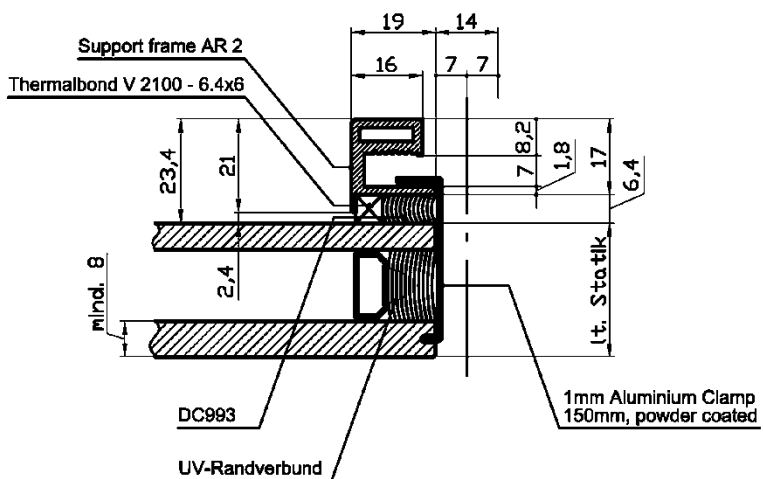

Glas Marte SG

Support frames with retaining devices MSR SG-K – double glazed insulating unit

Annex 6

Support Frame AR1:

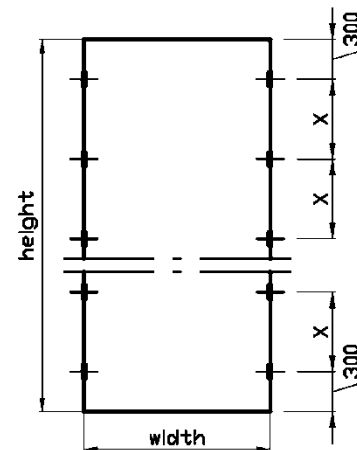
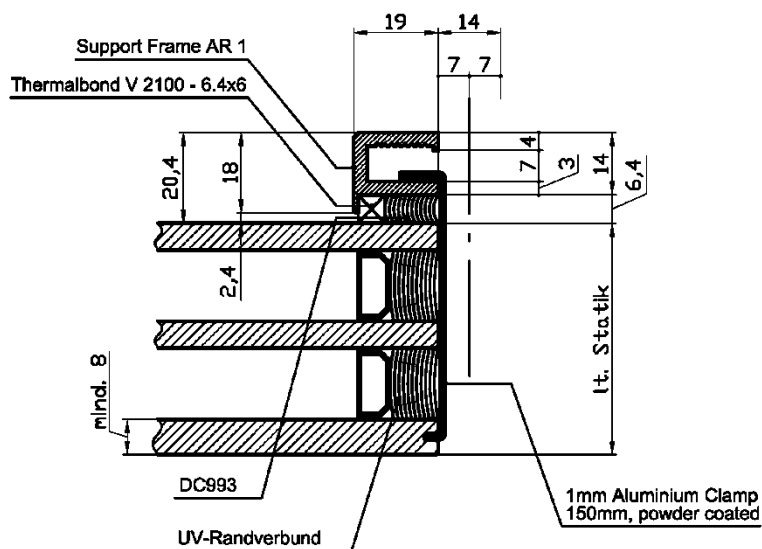

x = calculative detamination

Support Frame AR2:

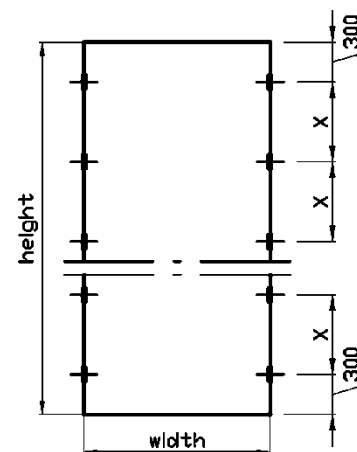
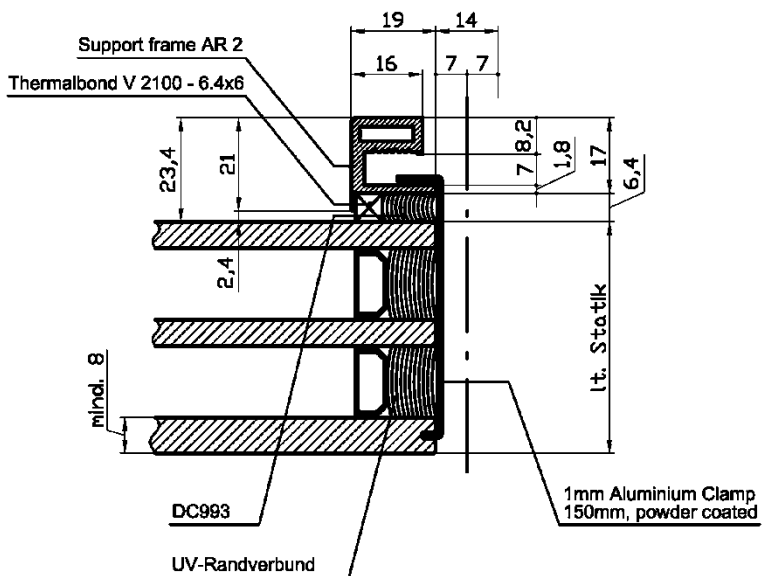

x = calculative detamination

Glas Marte SG

Support frames with retaining devices MSR SG-K – triple glazed insulating unit

Annex 7

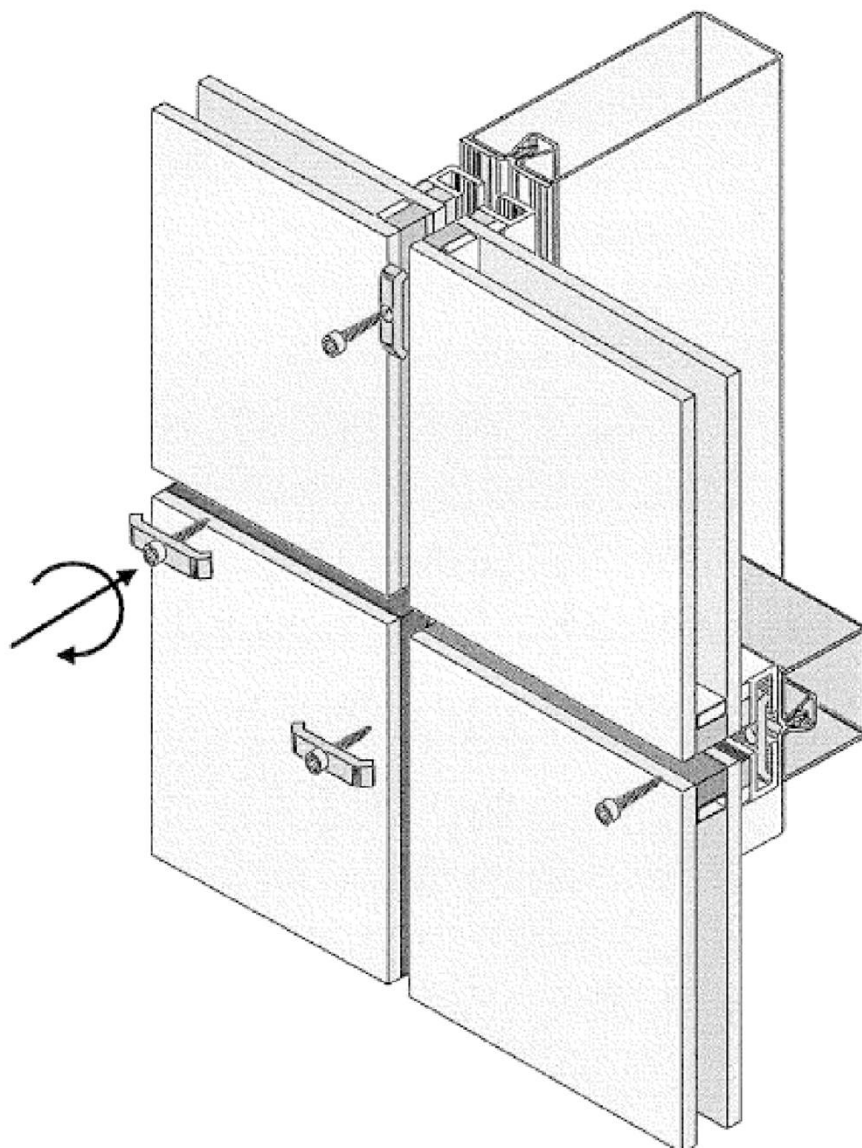

Installation:

1. Substructure shall be prepared with gasket support and glass support.
2. Setting blocks shall be placed
3. Infill elements shall be mounted with clamps. Maximum distance of the clamps 300 mm and/or according to the requirements of the stability verification. Maximum edge distance of the clamps 150 mm.
4. Placing of the backer rod.
5. Weather sealaning.

Glas Marte SG

Installation

Annex 8