

Public-law institution jointly founded by the federal states and the Federation

European Technical Assessment Body
for construction products



European Technical Assessment

ETA-11/0192
of 10 April 2026

English translation prepared by DIBt - Original version in German language

General Part

Technical Assessment Body issuing the European Technical Assessment:

Deutsches Institut für Bautechnik

Trade name of the construction product

EJOT H1 eco, EJOT H4 eco, EJOT H6 and ejotherm H1

Product family to which the construction product belongs

Plastic anchor for fixing of external thermal insulation composite systems with rendering

Manufacturer

EJOT SE & Co. KG
Astenbergstraße 21
57319 Bad Berleburg
GERMANY

Manufacturing plant

EJOT manufacturing plant 1, 2, 3, 4

This European Technical Assessment contains

26 pages including 3 annexes which form an integral part of this assessment

This European Technical Assessment is issued in accordance with Article 95(4) of Regulation (EU) 2024/3110, on the basis of

EAD 330196-01-0604

This version replaces

ETA-11/0192 issued on 6 December 2022

The European Technical Assessment is issued by the Technical Assessment Body in its official language. Translations of this European Technical Assessment in other languages shall fully correspond to the original issued document and shall be identified as such.

Communication of this European Technical Assessment, including transmission by electronic means, shall be in full. However, partial reproduction may only be made with the written consent of the issuing Technical Assessment Body. Any partial reproduction shall be identified as such.

This European Technical Assessment may be withdrawn by the issuing Technical Assessment Body, in particular pursuant to information by the Commission in accordance with Article 36(3) of Regulation (EU) No 2024/3110.

Specific Part

1 Technical description of the product

The nailed-in anchors EJOT H1 eco, EJOT H4 eco, EJOT H6 and ejotharm H1 consist of an anchor sleeve and an insulation plate made of virgin polyethylene an accompanying specific nail of galvanised steel and a mounting plug made of virgin polyamide.

For the anchor length of 95 mm (H1 eco and ejotharm H1) and for the anchor length of 115 –135 mm (EJOT H4 eco and EJOT H6) the accompanying specific nail of galvanised steel has an overmoulding of polyamide.

The anchor may in addition be combined with the anchor plates SBL 140 plus and VT 90.

An illustration and the description of the product are given in Annex A.

2 Specification of the intended use in accordance with the applicable European Assessment Document

The performances given in Section 3 are only valid if the anchor is used in compliance with the specifications and conditions given in Annex B.

The verifications and assessment methods on which this European Technical Assessment is based lead to the assumption of a working life of the anchor of at least 25 years. The indications given on the working life cannot be interpreted as a guarantee given by the producer, but are to be regarded only as a means for choosing the right products in relation to the expected economically reasonable working life of the works.

3 Performance of the product and references to the methods used for its assessment

3.1 Safety and accessibility in use (BWR 4)

Essential characteristic	Performance
Characteristic load bearing capacity <ul style="list-style-type: none">- Characteristic resistance under tension load- Minimum edge distance and spacing	See Annex C 1 See Annex B 2
Displacements	See Annex C 2, C 3, C 4 and C 5
Plate stiffness	See Annex C 2, C 3, C 4 and C 5

3.2 Energy economy and heat retention (BWR 6)

Essential characteristic	Performance
Point thermal transmittance	See Annex C 2, C 3, C 4 and C 5

4 Assessment and verification of constancy of performance (AVCP) system applied, with reference to its legal base

In accordance with EAD No. 330196-01-0604, the applicable European legal act is: [97/463/EC].

The system to be applied is: 2+

5 Technical details necessary for the implementation of the AVCP system, as provided for in the applicable European Assessment Document

Technical details necessary for the implementation of the AVCP system are laid down in the control plan deposited with Deutsches Institut für Bautechnik.

Issued in Berlin on 10 April 2026 by Deutsches Institut für Bautechnik

Dipl.-Ing. Beatrix Wittstock
Head of Section

beglaubigt:
Ziegler

EJOT H1 eco

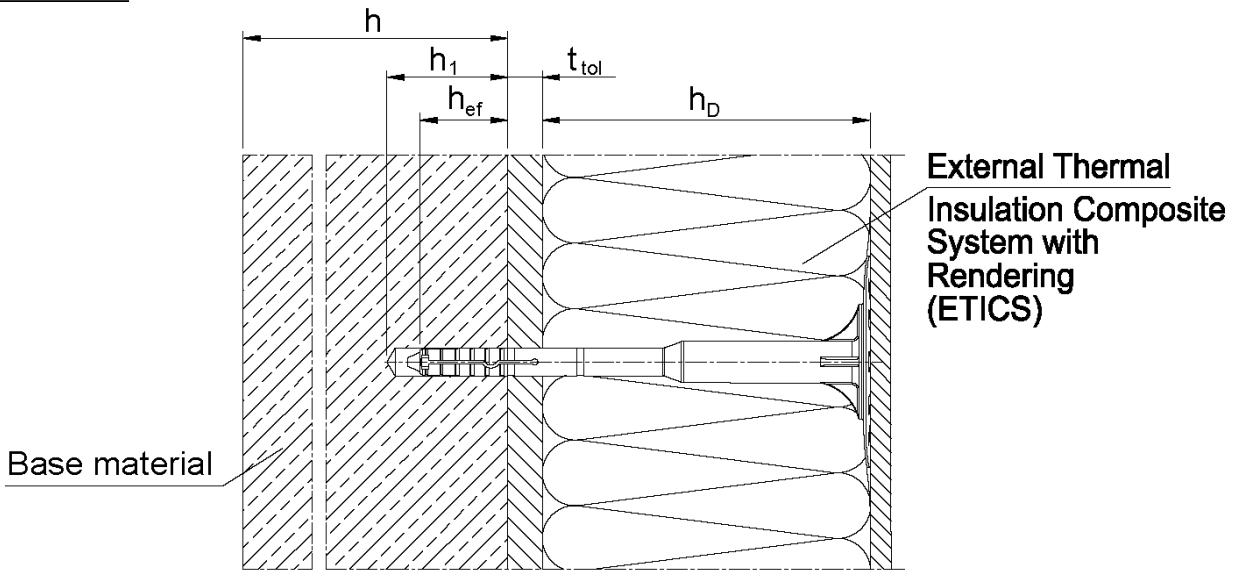

EJOT H4 eco

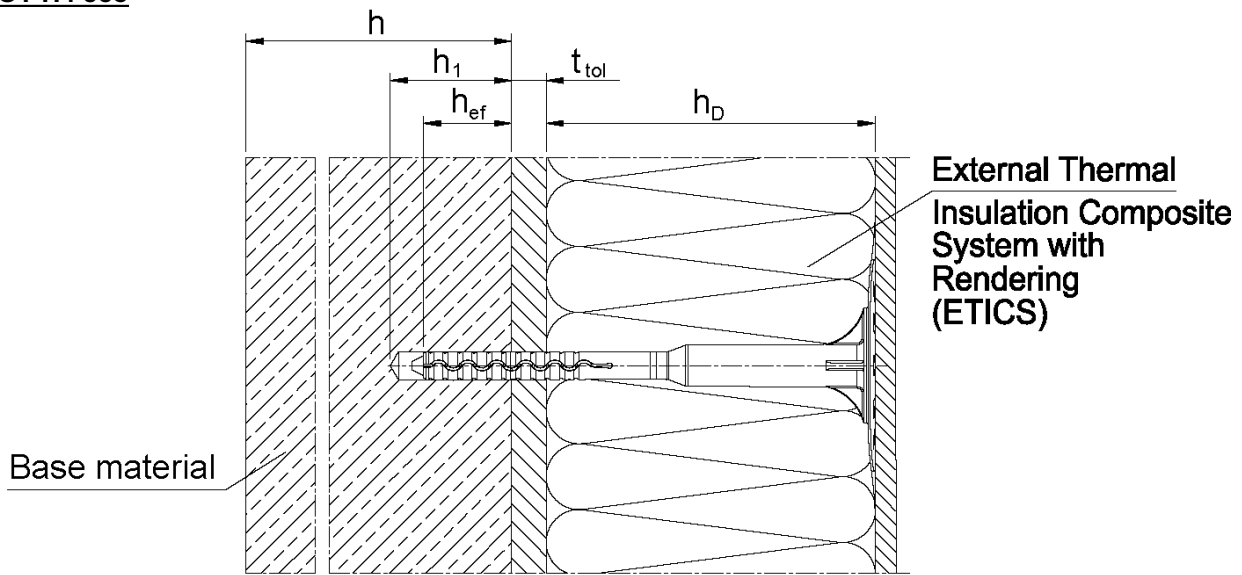

Intended use

- Anchorage of ETICS in concrete and masonry
- Anchorage of ETICS in autoclaved aerated concrete and lightweight aggregate concrete

Legend:

- h_D = thickness of insulation material
- h_{ef} = effective anchorage depth
- h = thickness of member (wall)
- h_1 = depth of drilled hole to deepest point
- t_{tol} = thickness of equalizing layer or non-load-bearing coating

EJOT H1 eco, EJOT H4 eco, EJOT H6 and ejotherm H1

Product description
Installed condition

Annex A 1

ejotherm H1

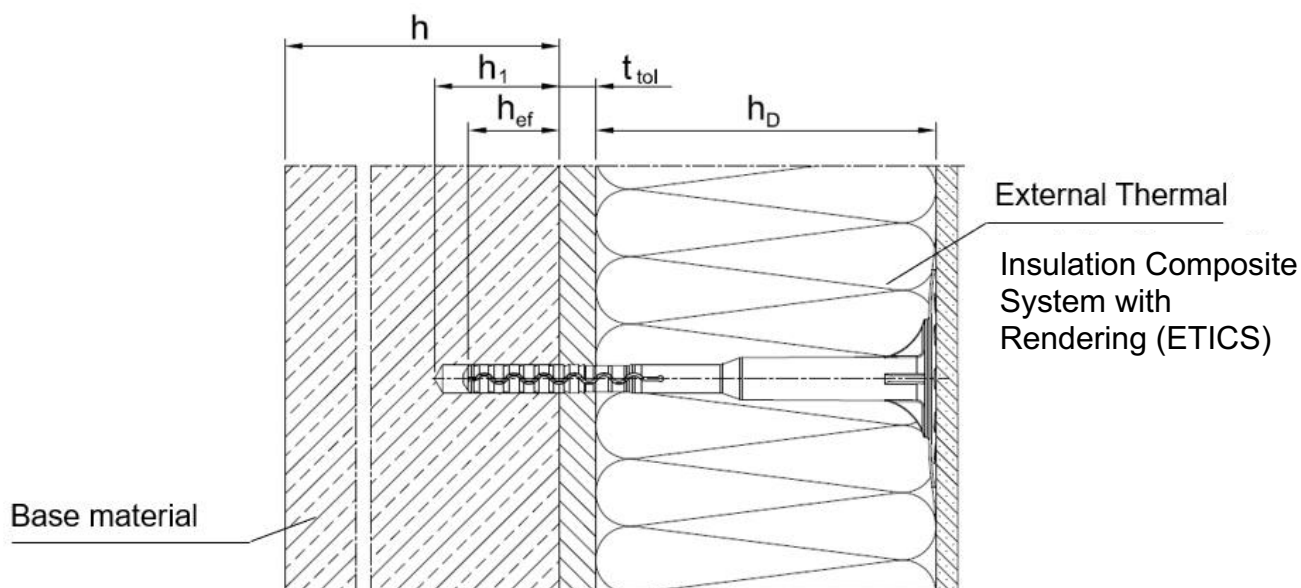

EJOT H6

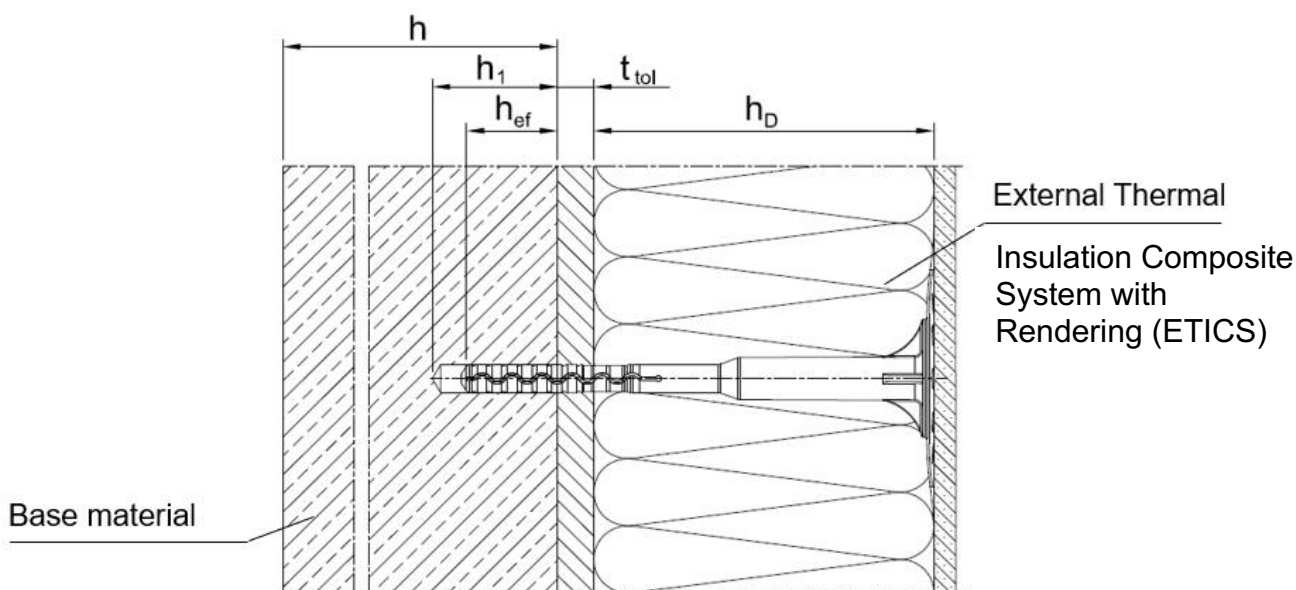

Intended use

- Anchorage of ETICS in concrete and masonry
- Anchorage of ETICS in autoclaved aerated concrete and lightweight aggregate concrete

Legend: h_D = thickness of insulation material
 h_{ef} = effective anchorage depth
 h = thickness of member (wall)
 h_1 = depth of drilled hole to deepest point
 t_{tol} = thickness of equalizing layer or non-load-bearing coating

EJOT H1 eco, EJOT H4 eco, EJOT H6 and ejotherm H1

Product description
Installed condition

Annex A 2

EJOT H1 eco / base material group: A, B, C

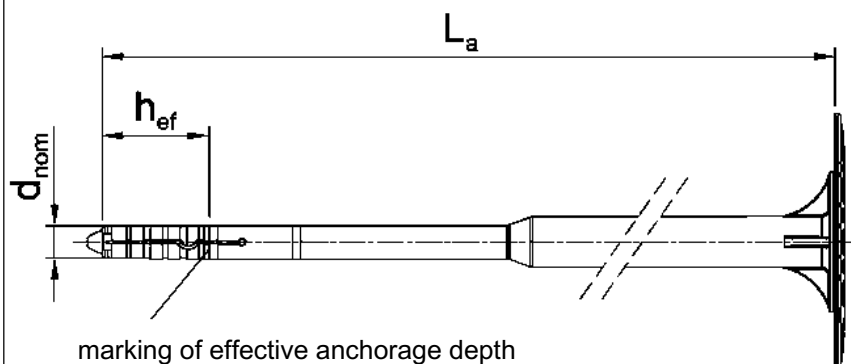

marking of effective anchorage depth

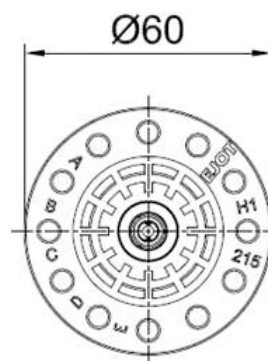

Marking of the anchor sleeve:
Identifying mark (EJOT)
Anchor type (H1 eco)
Base material group (A, B, C, D, E)
Length of anchor (e.g. 215)

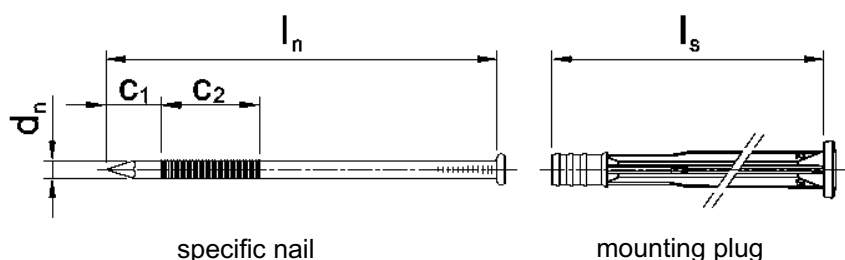

specific nail

mounting plug

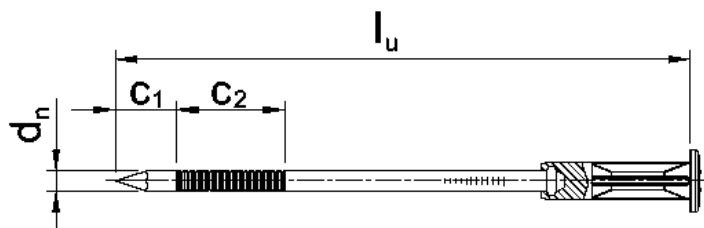

Anchor length 95 mm: specific overmoulded nail

Table A1: Dimensions

Anchor type	Anchor sleeve			Mounting plug min L _s max L _s	Specific nail				
	d _{nom} [mm]	h _{ef} [mm]	min L _a max L _a [mm]		d _n [mm]	C ₁ [mm]	C ₂ [mm]	min l _n max l _n [mm]	l _u [mm]
EJOT H1 eco	8	25	95 295	32 112	4,5	14	25	60 180	90

Determination of maximum thickness of insulation h_D [mm] EJOT H1 eco:

$$h_D = L_a - t_{tol} - h_{ef}$$

z.B. $h_D = 215 - 10 - 25$
 $h_{Dmax} = 180$

EJOT H1 eco, EJOT H4 eco, EJOT H6 and ejotherm H1

Product description

Marking and dimension of the anchor sleeve EJOT H1 eco
base material group: A, B, C, expansion element

Annex A 3

EJOT H1 eco / base material group: D and E

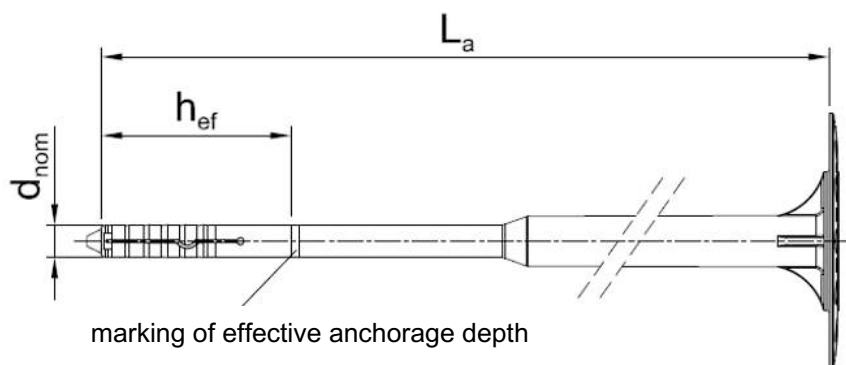

marking of effective anchorage depth

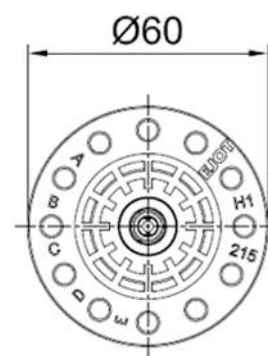

Marking of the anchor sleeve:
Identifying mark (EJOT)
Anchor type (H1 eco)
Base material group (A, B, C, D, E)
Length of anchor (e.g. 215)

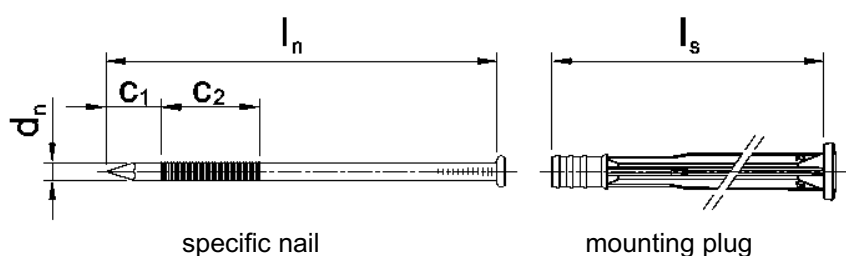

specific nail

mounting plug

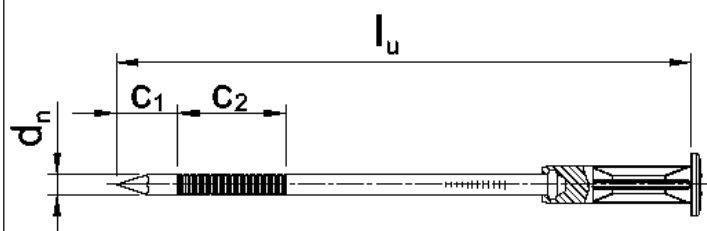

Anchor length 95 mm: specific overmoulded nail

Table A2: Dimensions

Anchor type	Anchor sleeve			Mounting plug min L _s max L _s	Specific nail				
	d _{nom} [mm]	h _{ef} [mm]	min L _a max L _a [mm]		d _n [mm]	c ₁ [mm]	c ₂ [mm]	min l _n max l _n [mm]	l _u [mm]
EJOT H1 eco	8	45	95 295	32 112	4,5	14	25	60 180	90

Determination of maximum thickness of insulation h_D [mm] EJOT H1 eco:

$$h_D = L_a - t_{tol} - h_{ef}$$

z.B. $h_D = 215 - 10 - 45$
 $h_{Dmax} = 160$

EJOT H1 eco, EJOT H4 eco, EJOT H6 and ejotherm H1

Product description

Marking and dimension of the anchor sleeve EJOT H1 eco
base material group: D, E, expansion element

Annex A 4

EJOT H4 eco / base material group: A, B, C

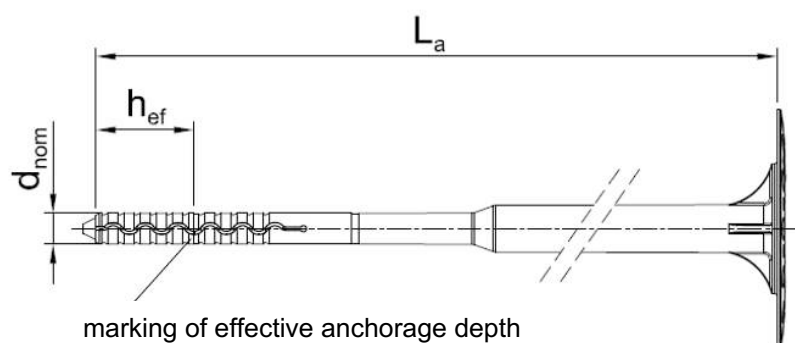

marking of effective anchorage depth

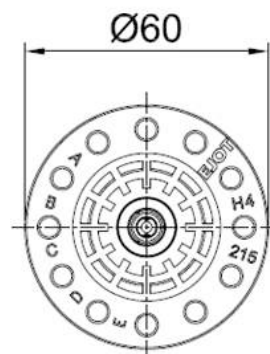

Marking of the anchor sleeve:
Identifying mark (EJOT)
Anchor type (H4 eco)
Base material group (A, B, C, D, E)
Length of anchor (e.g. 215)

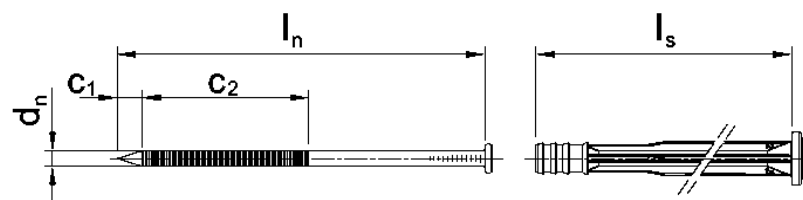

specific nail

mounting plug

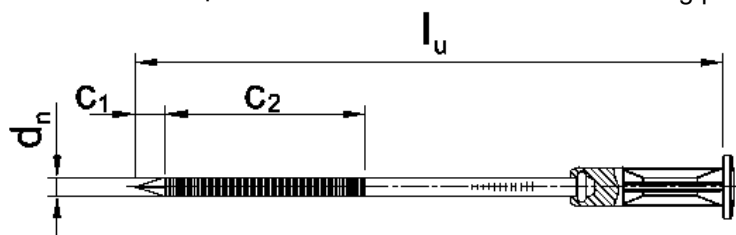

Anchor length 115 and 135 mm:
specific overmoulded nail

Table A3: Dimensions

Anchor type	Anchor sleeve			Mounting plug / overmoulding	Specific nail				
	d_{nom} [mm]	h_{ef} [mm]	min L_a max L_a [mm]		min L_s max L_s [mm]	d_n [mm]	c_1 [mm]	c_2 [mm]	min l_n max l_n [mm]
EJOT H4 eco	8	25	155 355	72 112	4,3	7,0	45	82 244	-
EJOT H4 eco	8	25	115 135	37	4,3	7,0	45		110 130

Determination of maximum thickness of insulation h_D [mm] EJOT H4 eco:

$$h_D = L_a - t_{tol} - h_{ef}$$

z.B. $h_D = 215 - 10 - 25$
 $h_{Dmax} = 180$

EJOT H1 eco, EJOT H4 eco, EJOT H6 and ejotherm H1

Product description

Marking and dimension of the anchor sleeve EJOT H4 eco
base material group: A, B, C, expansion element

Annex A 5

EJOT H4 eco / base material group: D and E

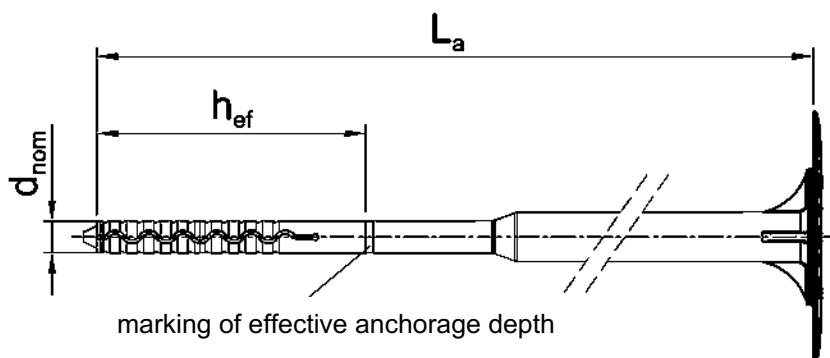

marking of effective anchorage depth

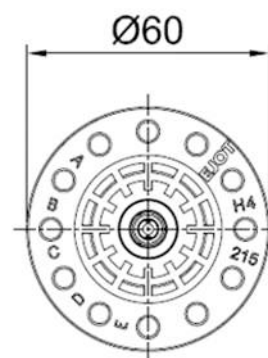

Marking of the anchor sleeve:
Identifying mark (EJOT)
Anchor type (H4 eco)
Base material group (A, B, C, D, E)
Length of anchor (e.g. 215)

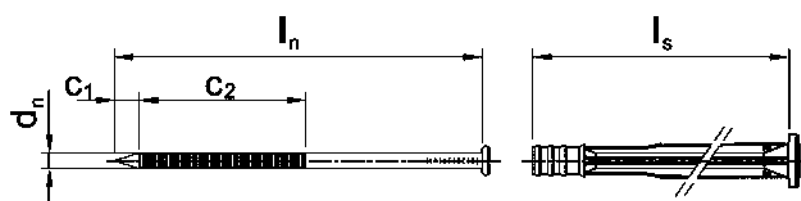

specific nail

mounting plug

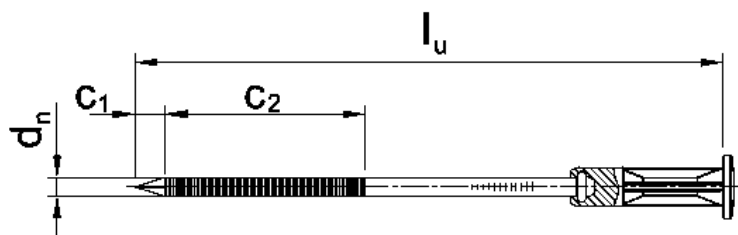

Anchor length 115 and 135 mm:
specific overmoulded nail

Table A4: Dimensions

Anchor type	Anchor sleeve			Mounting plug / overmoulding	Specific nail				
	d _{nom} [mm]	h _{ef} [mm]	min L _a max L _a [mm]		min L _s max L _s [mm]	d _n [mm]	c ₁ [mm]	c ₂ [mm]	min l _n max l _n [mm]
EJOT H4 eco	8	65	155 355	72 112	4,3	7,0	45	82 244	-
EJOT H4 eco	8	65	115 135	37	4,3	7,0	45		110 130

Determination of maximum thickness of insulation h_D [mm] EJOT H4 eco:

$$h_D = L_a - t_{tol} - h_{ef}$$

z.B. $h_D = 215 - 10 - 65$
 $h_{Dmax} = 140$

EJOT H1 eco, EJOT H4 eco, EJOT H6 and ejotherm H1

Product description

Marking and dimension of the anchor sleeve EJOT H4 eco
base material group: D, E, expansion element

Annex A 6

EJOT H6 / base material group: A, B, C

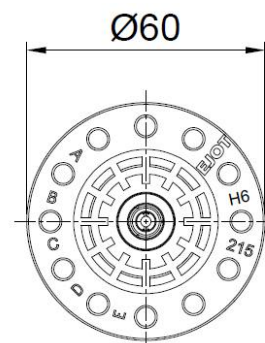
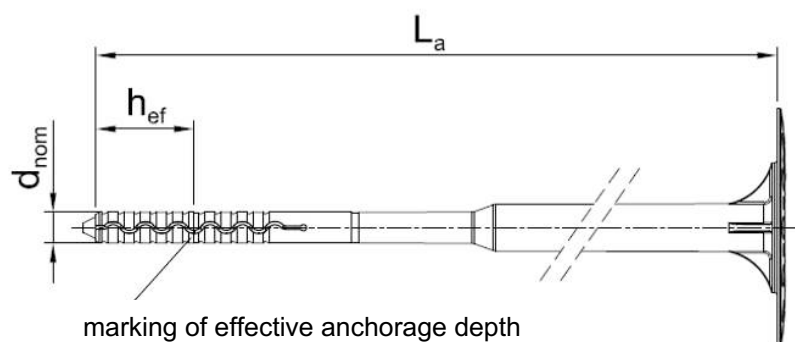

Marking of the anchor sleeve:
Identifying mark (EJOT)
Anchor type (H6)
Base material group (A, B, C, D, E)
Length of anchor (e.g. 215)

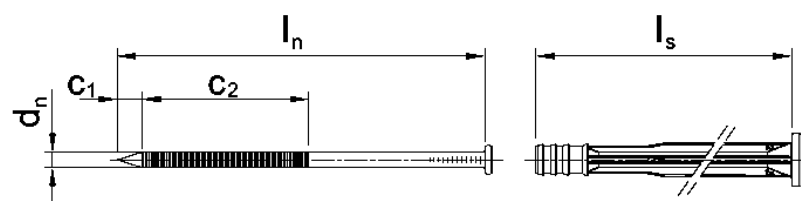

specific nail

mounting plug

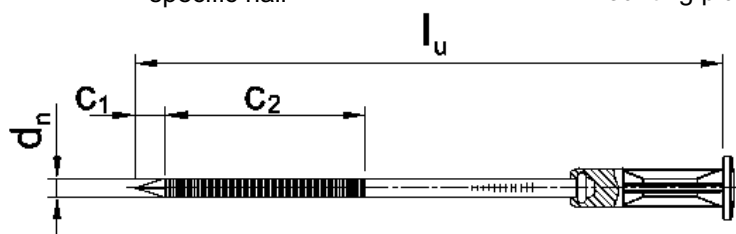

Anchor length 115 and 135 mm:
specific overmoulded nail

Table A5: Dimensions

Anchor type	Anchor sleeve			Mounting plug / overmoulding	Specific nail				
	d_{nom} [mm]	h_{ef} [mm]	min L_a max L_a [mm]		min L_s max L_s [mm]	d_n [mm]	c_1 [mm]	c_2 [mm]	min l_n max l_n [mm]
EJOT H6	8	25	155 355	72 112	4,3	7,0	45	82 244	-
EJOT H6	8	25	115 135	32	4,3	7,0	45		110 130

Determination of maximum thickness of insulation h_D [mm] EJOT H6:

$$h_D = L_a - t_{tol} - h_{ef}$$

z.B. $h_D = 215 - 10 - 25$
 $h_{Dmax} = 180$

EJOT H1 eco, EJOT H4 eco, EJOT H6 and ejotherm H1

Product description

Marking and dimension of the anchor sleeve EJOT H6
base material group: A, B, C, expansion element

Annex A 7

EJOT H6 / base material group: D and E

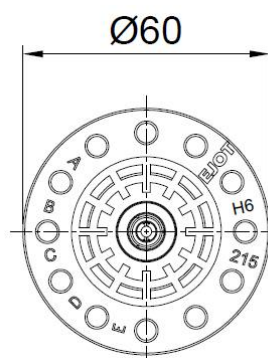
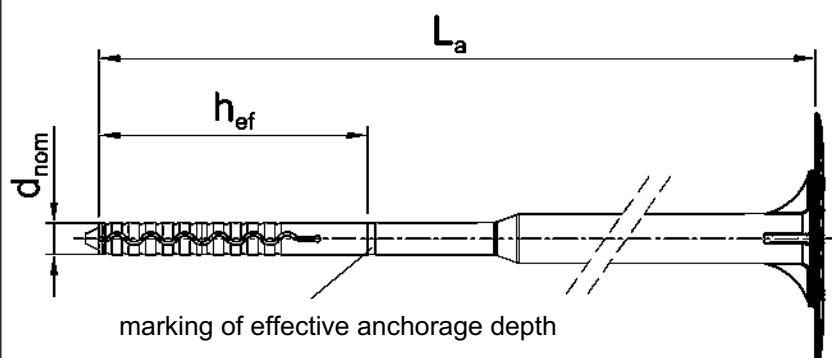

Marking of the anchor sleeve:
Identifying mark (EJOT)
Anchor type (H6)
Base material group (A, B, C, D, E)
Length of anchor (e.g. 215)

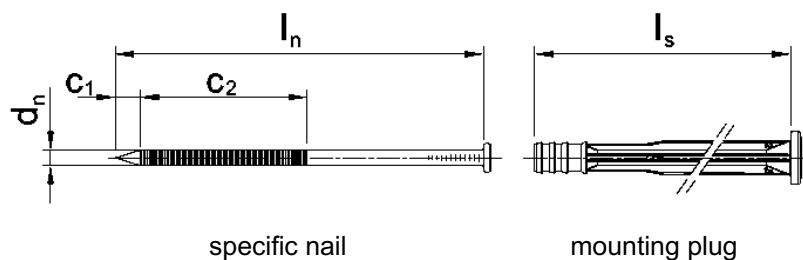

specific nail

mounting plug

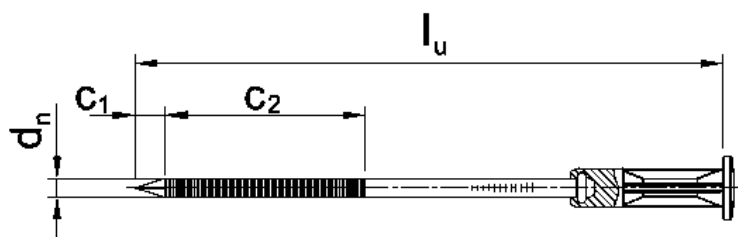

Anchor length 115 and 135 mm:
specific overmoulded nail

Table A6: Dimensions

Anchor type	Anchor sleeve			Mounting plug / overmoulding	Specific nail				
	d _{nom} [mm]	h _{ef} [mm]	min L _a max L _a [mm]		min L _s max L _s [mm]	d _n [mm]	c ₁ [mm]	c ₂ [mm]	min l _n max l _n [mm]
EJOT H6	8	65	155 355	72 112	4,3	7,0	45	82 244	-
EJOT H6	8	65	115 135	37	4,3	7,0	45		110 130

Determination of maximum thickness of insulation h_D [mm] EJOT H6:

$$h_D = L_a - t_{tol} - h_{ef}$$

z.B. $h_D = 215 - 10 - 65$
 $h_{Dmax} = 140$

EJOT H1 eco, EJOT H4 eco, EJOT H6 and ejotherm H1

Product description
Marking and dimension from EJOT H6
base material group: D, E, expansion element

Annex A 8

ejotherm H1 / base material group: A, B, C

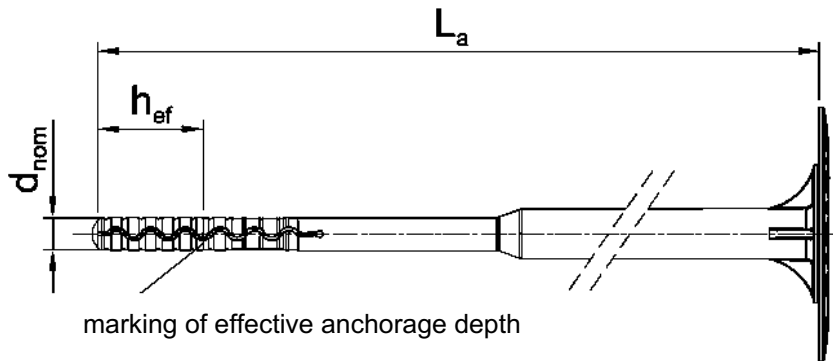

marking of effective anchorage depth

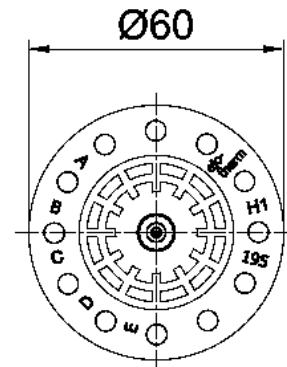

Marking of the anchor sleeve:
Identifying mark (ejotherm)
Anchor type (H1)
Base material group (A, B, C, D, E)
Length of anchor (e.g. 195)

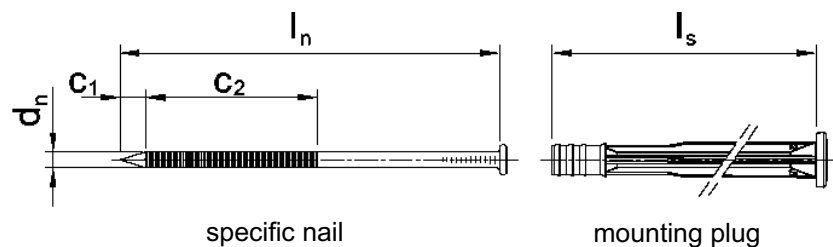

specific nail

mounting plug

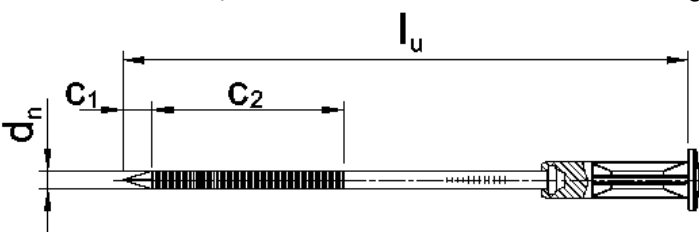

Anchor length 95 mm: specific overmoulded nail

Table A7: Dimensions

Anchor type	Anchor sleeve			Mounting plug / overmoulding	Specific nail				
	d_{nom} [mm]	h_{ef} [mm]	min L_a max L_a [mm]		min L_s max L_s [mm]	d_n [mm]	c_1 [mm]	c_2 [mm]	min l_n max l_n [mm]
ejotherm H1	8	25	115 355	52 112	4,3	7,0	45	62 244	-
ejotherm H1	8	25	95	37	4,3	7,0	45		95

Determination of maximum thickness of insulation h_D [mm] ejotherm H1:

$$h_D = L_a - t_{tol} - h_{ef}$$

z.B. $h_D = 195 - 10 - 25$
 $h_{Dmax} = 160$

EJOT H1 eco, EJOT H4 eco, EJOT H6 and ejotherm H1

Product description

Marking and dimension of the anchor sleeve ejotherm H1
base material group: A, B, C, expansion element

Annex A 9

ejotherm H1 / base material group: D and E

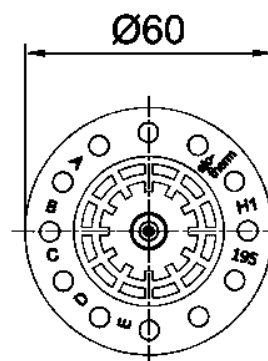
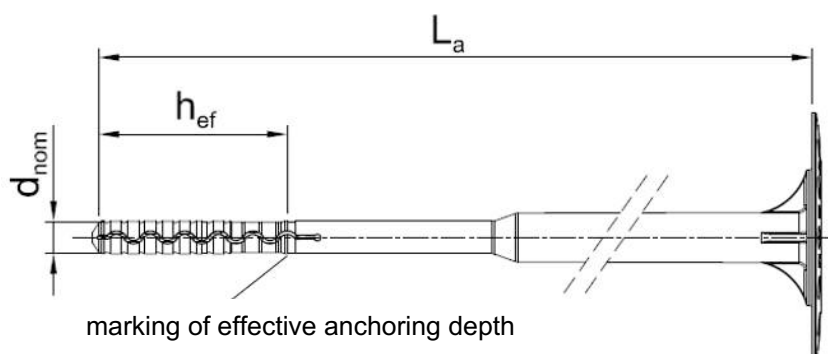

Marking of the anchor sleeve:
Identifying mark (ejotherm)
Anchor type (H1)
Base material group (A, B, C, D, E)
Length of anchor (e.g. 195)

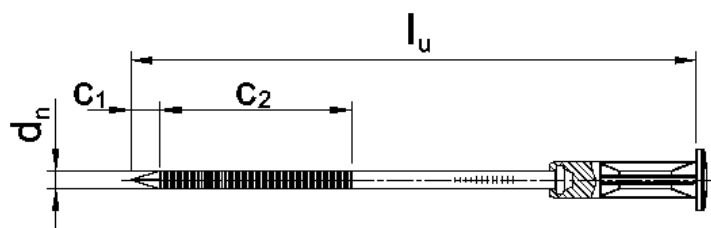
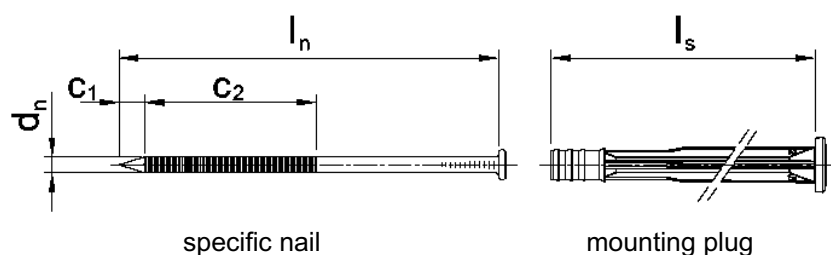

Anchor length 95 mm: specific overmoulded nail

Table A8: Dimensions

Anchor type	Anchor sleeve			Mounting plug / overmoulding	Specific nail				
	d_{nom} [mm]	h_{ef} [mm]	min L_a max L_a [mm]		min L_s max L_s [mm]	d_n [mm]	c_1 [mm]	c_2 [mm]	min l_n max l_n [mm]
ejotherm H1	8	45	115 355	52 112	4,3	7,0	45	62 244	-
ejotherm H1	8	45	95	37	4,3	7,0	45		95

Determination of maximum thickness of insulation h_D [mm] ejotherm H1:

$$h_D = L_a - t_{tol} - h_{ef}$$

z.B. $h_D = 195 - 10 - 45$
 $h_{Dmax} = 140$

EJOT H1 eco, EJOT H4 eco, EJOT H6 and ejotherm H1

Product description
Marking and dimension of the anchor sleeve ejotherm H1
base material group: D, E, expansion element

Annex A 10

Table A9: Materials EJOT H1 eco, EJOT H4 eco, EJOT H6 und ejothem H1

Name	Materials
Anchor sleeve	virgin Polyethylene, PE-HD Colours: nature, yellow, orange, red, blue, grey, white, green, anthracite
Mounting plug	virgin Polyamide, PA 6 GF 50 Colour: nature
Specific nail	Steel, electro galvanised $\geq 5 \mu\text{m}$ zinc, according EN ISO 4042: 2022 blue passivated, $f_{yk} \geq 670 \text{ N/mm}^2$
Slip on plate	Polyamide PA 6, Polyamide PA 6 GF 50

SBL 140 plus

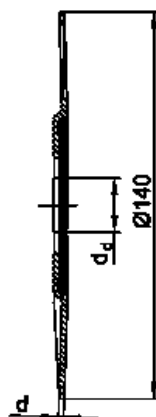
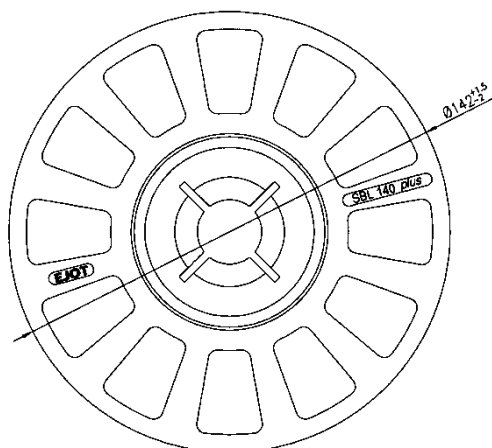

SBL 140 plus	
d_d [mm]	21,0
d [mm]	2,0

VT 90

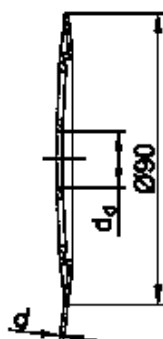
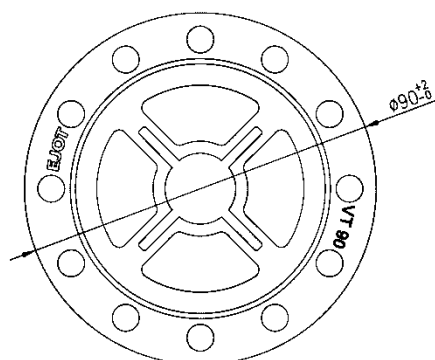

VT 90	
d_d [mm]	18,5
d [mm]	1,2

EJOT H1 eco, EJOT H4 eco, EJOT H6 and ejothem H1

Product description

Materials and slip on plates for EJOT H1 eco, EJOT H4 eco, EJOT H6 and ejothem H1

Annex A 11

Specifications of intended use

Anchorage subject to:

- The anchor may only be used for transmission of wind suction loads and shall not be used for the transmission of dead loads of the thermal insulation composite system.

Base materials:

- Compacted normal weight concrete without fibres (base material group A) according to Annex C 1.
- Solid masonry (base material group B), according to Annex C 1.
- Hollow or perforated masonry (base material group C), according to Annex C 1.
- Prefabricated reinforced components of lightweight aggregate concrete (LAC) (base material group D), according to Annex C 1.
- Autoclaved aerated concrete (base material group E), according to Annex C 1.
- For other base materials of base material groups A, B, C, D or E the characteristic resistance of the anchor may be determined by job site tests in accordance with EOTA Technical Report TR 51 edition April 2018.

Temperature Range:

- 0°C to +40°C (max. short term temperature +40°C and max. long term temperature +24°C)

Design:

- The anchorages are designed under the responsibility of an engineer experienced in accordance and masonry work with the partial safety factors $\gamma_m = 2,0$ and $\gamma_F = 1,5$ if there are no other regulations.
- Verifiable calculation notes and drawings are prepared taking account of the loads to be anchored. The position of the anchor is indicated on the design drawings.
- Fasteners are only to be used for multiple fixings of thermal insulation composite systems.

Installation:

- Hole drilling by the drill modes according to Annex C 1.
- Anchor installation carried out by appropriately qualified personnel and under the supervision of the person responsible for technical matters of the site.
- Installation temperature from 0°C to +40°C
- Exposure to UV due to solar radiation of the anchor not protected by rendering ≤ 6 weeks

EJOT H1 eco, EJOT H4 eco, EJOT H6 and ejotharm H1	
Intended use Specifications	Annex B 1

Table B1: Installation Parameters

Anchor type		EJOT H1 eco		EJOT H4 eco EJOT H6		ejotherm H1	
		A B C	D E	A B C	D E	A B C	D E
Drill hole diameter	d_0 [mm] =	8	8	8	8	8	8
Cutting diameter of drill bit	d_{cut} [mm] ≤	8,45	8,45	8,45	8,45	8,45	8,45
Depth of drilled hole to deepest point	h_1 [mm] ≥	35	55	35	75	35	55
Effective anchorage depth	h_{ef} [mm] ≥	25	45	25	65	25	45

Table B2: Anchor distances and dimensions of members

Anchor type		EJOT H1 eco / EJOT H4 eco / EJOT H6 / ejotherm H1
Minimum spacing	$s_{min} \geq$ [mm]	100
Minimum edge distance	$c_{min} \geq$ [mm]	100
Minimum thickness of member	$h \geq$ [mm]	100

Scheme of distance and spacing

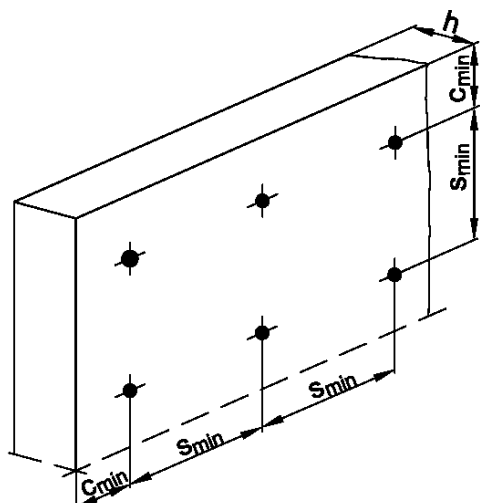

EJOT H1 eco, EJOT H4 eco, EJOT H6 and ejotherm H1

Intended use
Installation parameters,
Edge distances and spacing

Annex B 2

Installation instructions EJOT H1 eco

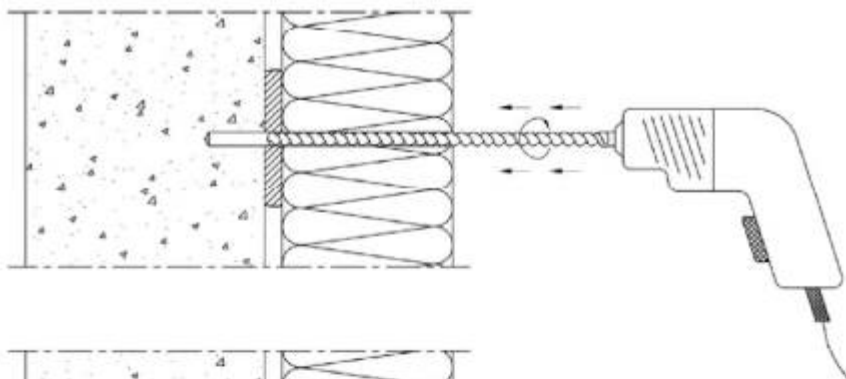

Drill the hole perpendicular to the substrate surface.
Clean the drill hole 3x.

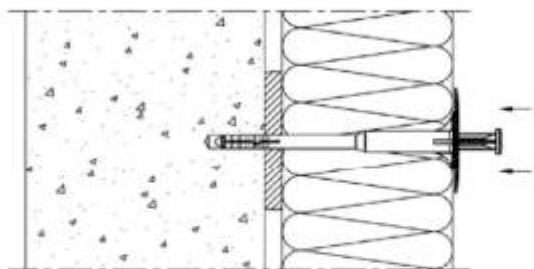

Place the anchor into the drill hole.
The bottom side of the plate must be flush with the insulation.

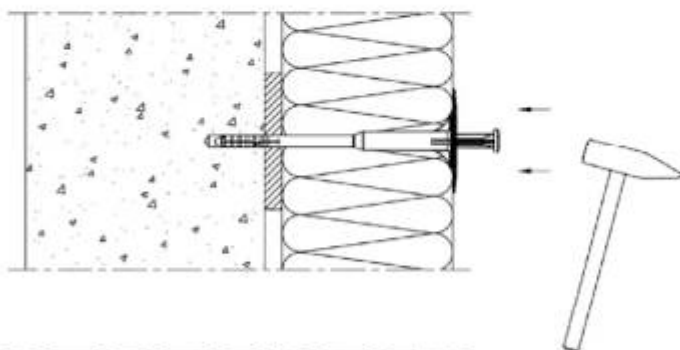

Drive in the specific nail with the hammer.

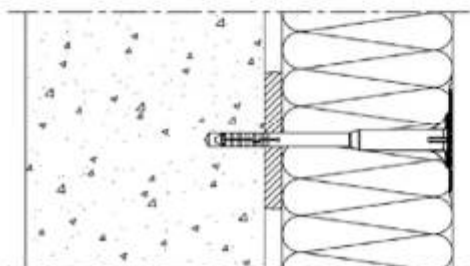

Installed condition of
EJOT H1 eco.

EJOT H1 eco, EJOT H4 eco, EJOT H6 and ejotharm H1

Intended use
Installation instructions EJOT H1 eco

Annex B 3

Installation instructions EJOT H4 eco

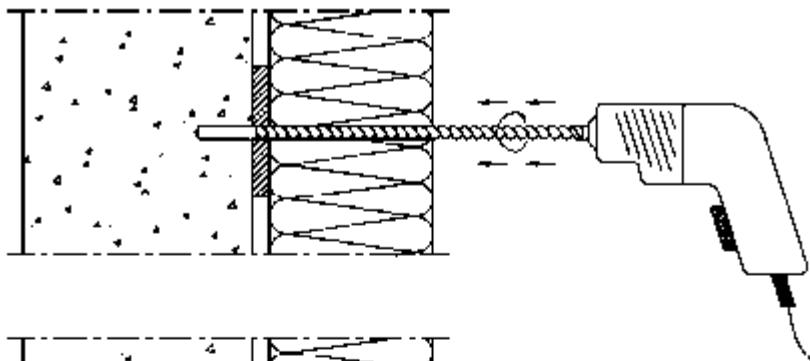

Drill the hole perpendicular to the substrate surface.
Clean the drill hole 3x.

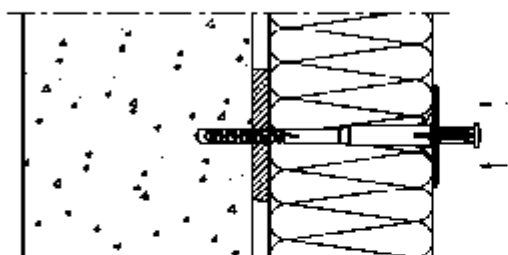

Place the anchor into the drill hole.
The bottom side of the plate must be flush with the insulation.

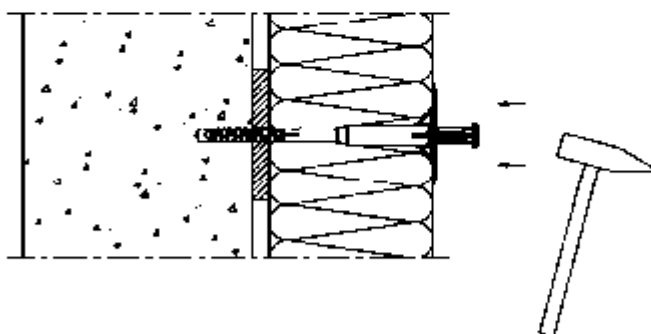

Drive in the specific nail with the hammer.

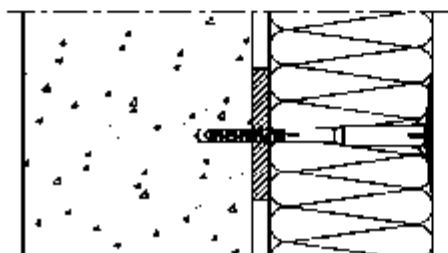

Installed condition of
EJOT H4 eco.

EJOT H1 eco, EJOT H4 eco, EJOT H6 and ejotherm H1

Intended use
Installation instructions EJOT H4 eco

Annex B 4

Installation instructions EJOT H6

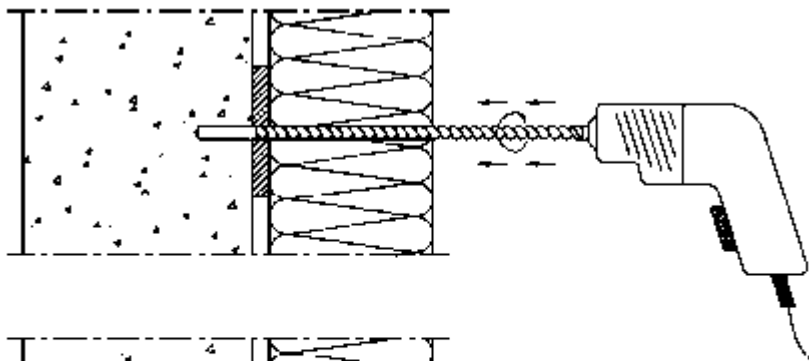

Drill the hole perpendicular to the substrate surface.
Clean the drill hole 3x.

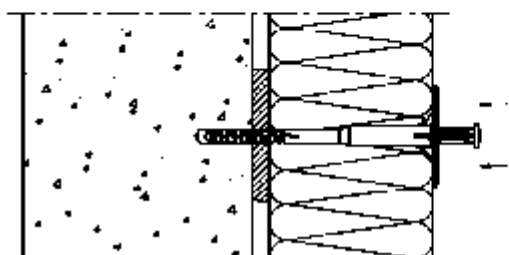

Place the anchor into the drill hole.
The bottom side of the plate must be flush with the insulation.

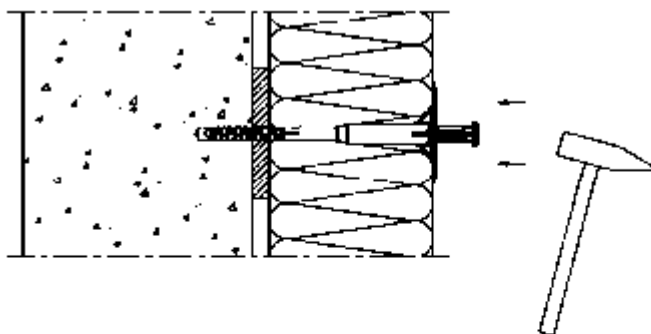

Drive in the specific nail with the hammer.

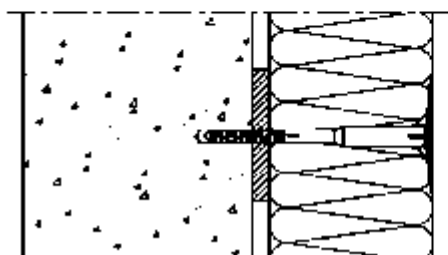

Installed condition of
EJOT H6.

EJOT H1 eco, EJOT H4 eco, EJOT H6 and ejotherm H1

Intended use
Installation instructions EJOT H6

Annex B 5

Installation instructions ejotherm H1

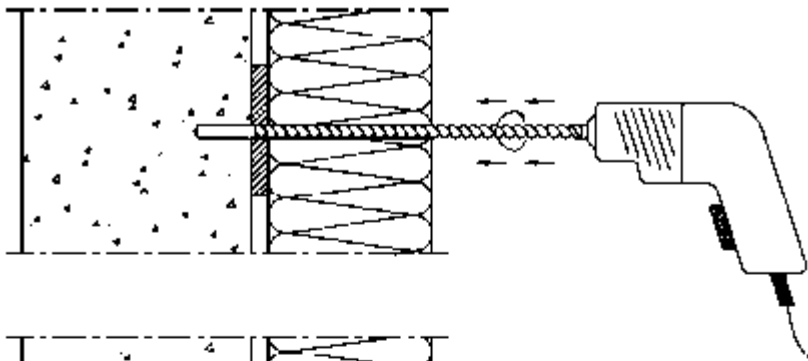

Drill the hole perpendicular to the substrate surface.
Clean the drill hole 3x.

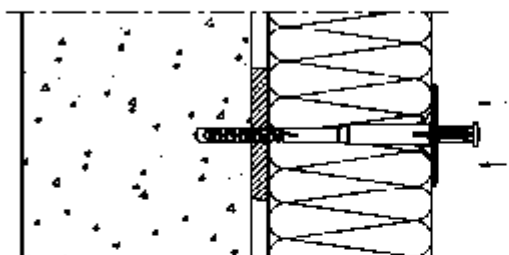

Place the anchor into the drill hole.
The bottom side of the plate must be flush with the insulation.

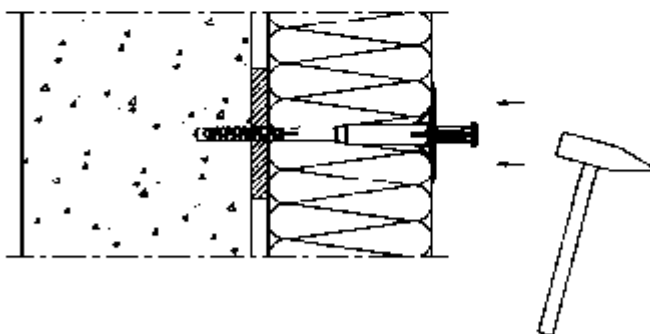

Drive in the specific nail with the hammer.

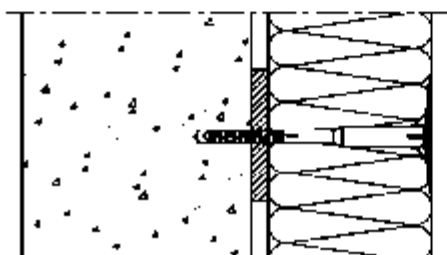

Installed condition of
ejotherm H1.

EJOT H1 eco, EJOT H4 eco, EJOT H6 and ejotherm H1

Intended use
Installation instructions ejotherm H1

Annex B 6

Table C1: Characteristic resistance to tension loads N_{Rk} in concrete and masonry for a single anchor in kN								
					EJOT H1 eco	EJOT H4 eco	EJOT H6	ejo- therm H1
Base materials	Bulk density ρ [kg/dm ³]	Min. com- pressive strength f_b [N/mm ²]	General remarks	Drill method	N_{Rk} [kN]	N_{Rk} [kN]	N_{Rk} [kN]	N_{Rk} [kN]
Concrete C 12/15			Compacted normal weight concrete without fibres, strength class as per EN 206:2013 +A1:2016	hammer	0,9	0,5	-,5)	0,9
Concrete C 20/25 – C 50/60				hammer	0,9	0,75	0,6	1,2
Concrete C 20/25 – C 50/60 thin concrete members: 100 mm > h ≥ 40 mm (thin skin)				hammer	-,5)	-,5)	-,5)	1,2
Clay bricks, Mz, as per EN 771-1:2011+A1:2015	≥ 1,8	12	perforation ⁴⁾ up to 15 %.	hammer	0,9	0,75	0,6	1,2
Sand-lime solid bricks, KS as per EN 771-2:2011+A1:2015	≥ 1,8	12	perforation ⁴⁾ up to 15 %.	hammer	0,9	0,75	0,6	1,2
Vertically perforated clay bricks, HLZ as per EN 771-1:2011+A1:2015	≥ 1,2	20	perforation ⁴⁾ >15% and ≤50%	rotary	0,75 ¹⁾	-,5)	-,5)	-,5)
Vertically perforated clay bricks, HLZ as per EN 771-1:2011+A1:2015	≥ 0,9	12	perforation ⁴⁾ >15% and ≤50%	rotary	0,6 ²⁾	0,5 ²⁾	0,45 ²⁾	-,5)
Vertically perforated clay bricks, HLZ as per EN 771-1:2011+A1:2015	≥ 0,8	12	perforation ⁴⁾ >15% and ≤50%	rotary	-,5)	-,5)	-,5)	0,75 ²⁾
Sand-lime perforated bricks, KSL as per EN 771-2:2011+A1:2015	≥ 1,4	12	perforation ⁴⁾ >15% and ≤50%	rotary	0,9 ³⁾	0,75 ³⁾	0,6 ³⁾	1,2 ³⁾
lightweight aggregate concrete, LAC as per EN 1520:2011, EN 771-3:2011+A1:2015	≥ 1,2	4		hammer	0,9	1,2	0,75	1,1
Autoclaved aerated concrete as per EN 771- 4:2011 +A1:2015	≥ 0,6	4		rotary	0,5	0,5	0,45	0,9

1) The value applies only for outer web thickness ≥ 14 mm; otherwise N_{Rk} shall be determined by job site pull-out tests.
2) The value applies only for outer web thickness ≥ 11 mm; otherwise N_{Rk} shall be determined by job site pull-out tests.
3) The value applies only for outer web thickness ≥ 20 mm; otherwise N_{Rk} shall be determined by job site pull-out tests.
4) Cross section reduced by perforation vertically to the resting area
5) No performance assessed

EJOT H1 eco, EJOT H4 eco, EJOT H6 and ejotherm H1	Annex C 1
Performances Characteristic resistance	

EJOT H1 eco

Table C2: Point thermal transmittance according EOTA Technical Report TR 025:2016-05

anchor type	insulation thickness h_D [mm]	point thermal transmittance χ [W/K]
EJOT H1 eco	60 – 260	0,001

Table C3: Plate stiffness according EOTA Technical Report TR 026:2016-05

anchor type	diameter of the anchor plate [mm]	load resistance of the anchor plate [kN]	plate stiffness [kN/mm]
EJOT H1 eco	60	1,4	0,6

Table C4: Displacements EJOT H1 eco

Base materials	Bulk density ρ [kg/dm ³]	minimum compressive strength f_b [N/mm ²]	Tension load N [kN]	Displacements $\Delta\delta_N$ [mm]
Concrete C 12/15 – C 50/60 (EN 206:2013+A1:2016)			0,3	0,3
Clay bricks, Mz (EN 771-1:2011+A1:2015)	$\geq 1,8$	12	0,3	0,3
Sand-lime solid bricks, KS (EN 771-2:2011+A1:2015)	$\geq 1,8$	12	0,3	0,3
Vertically perforated clay bricks, HLz (EN 771-1:2011+A1:2015)	$\geq 1,2$	20	0,25	0,4
Vertically perforated clay bricks, HLz (EN 771-1:2011+A1:2015)	$\geq 0,9$	12	0,2	0,2
Sand-lime perforated bricks, KSL (EN 771-2:2011+A1:2015)	$\geq 1,4$	12	0,3	0,3
Lightweight aggregate concrete, LAC (EN 1520:2011 / EN 771-3:2011+A1:2015)	$\geq 1,2$	4	0,3	1,1
Autoclaved aerated concrete (EN 771-4:2011+A1:2015)	$\geq 0,6$	4	0,17	0,7

EJOT H1 eco, EJOT H4 eco, EJOT H6 and ejotherm H1

Performances
Point thermal transmittance, plate stiffness, displacements
EJOT H1 eco

Annex C 2

EJOT H4 eco

Table C5: Point thermal transmittance according EOTA Technical Report TR 025:2016-05

anchor type	insulation thickness h_D [mm]	point thermal transmittance χ [W/K]
EJOT H4 eco	60 – 320	0,001

Table C6: Plate stiffness according EOTA Technical Report TR 026:2016-05

anchor type	diameter of the anchor plate [mm]	load resistance of the anchor plate [kN]	plate stiffness [kN/mm]
EJOT H4 eco	60	1,4	0,6

Table C7: Displacements EJOT H4 eco

Base materials	Bulk density ρ [kg/dm ³]	minimum compressive strength f_b [N/mm ²]	Tension load N [kN]	Displacements $\Delta\delta_N$ [mm]
Concrete C 12/15 – C 50/60 (EN 206:2013+A1:2016)			0,25	0,6
Clay bricks, Mz (EN 771-1:2011+A1:2015)	$\geq 1,8$	12	0,25	0,4
Sand-lime solid bricks, KS (EN 771-2:2011+A1:2015)	$\geq 1,8$	12	0,25	0,4
Vertically perforated clay bricks, HLz (EN 771-1:2011+A1:2015)	$\geq 0,9$	12	0,15	0,6
Sand-lime perforated bricks, KSL (EN 771-2:2011+A1:2015)	$\geq 1,4$	12	0,25	0,4
Lightweight aggregate concrete, LAC (EN 1520:2011 / EN 771-3:2011+A1:2015)	$\geq 1,2$	4	0,4	1,3
Autoclaved aerated concrete (EN 771-4:2011+A1:2015)	$\geq 0,6$	4	0,17	0,6

EJOT H1 eco, EJOT H4 eco, EJOT H6 and ejotherm H1

Performances
Point thermal transmittance, plate stiffness, displacements
EJOT H4 eco

Annex C 3

EJOT H6

Table C8: Point thermal transmittance according EOTA Technical Report TR 025:2016-05

anchor type	insulation thickness h_D [mm]	point thermal transmittance χ [W/K]
EJOT H6	60 – 320	0,001

Table C9: Plate stiffness according EOTA Technical Report TR 026:2016-05

anchor type	diameter of the anchor plate [mm]	load resistance of the anchor plate [kN]	plate stiffness [kN/mm]
EJOT H6	60	1,4	0,6

Table C10: Displacements EJOT H6

Base materials	Bulk density ρ [kg/dm ³]	minimum compressive strength f_b [N/mm ²]	Tension load N [kN]	Displacements $\Delta\delta_N$ [mm]
Concrete C20/25 – C50/60 (EN 206:2013+A1:2016)			0,20	0,6
Clay bricks, Mz (EN 771-1:2011+A1:2015)	$\geq 1,8$	12	0,20	0,4
Sand-lime solid bricks, KS (EN 771-2:2011+A1:2015)	$\geq 1,8$	12	0,20	0,4
Vertically perforated clay bricks, HLz (EN 771-1:2011+A1:2015)	$\geq 0,9$	12	0,15	0,6
Sand-lime perforated bricks, KSL (EN 771-2:2011+A1:2015)	$\geq 1,4$	12	0,20	0,4
Lightweight aggregate concrete, LAC (EN 1520:2011 / EN 771-3:2011+A1:2015)	$\geq 1,2$	4	0,25	1,3
Autoclaved aerated concrete (EN 771-4:2011+A1:2015)	$\geq 0,6$	4	0,15	0,6

EJOT H1 eco, EJOT H4 eco, EJOT H6 and ejotherm H1

Performances
Point thermal transmittance, plate stiffness, displacements
EJOT H6

Annex C 4

ejotherm H1

Table C11: Point thermal transmittance according EOTA Technical Report TR 025:2016-05

anchor type	insulation thickness h_D [mm]	point thermal transmittance χ [W/K]
ejotherm H1	60 – 320	0,001

Table C12: Plate stiffness according EOTA Technical Report TR 026:2016-05

anchor type	diameter of the anchor plate [mm]	load resistance of the anchor plate [kN]	plate stiffness [kN/mm]
ejotherm H1	60	1,4	0,6

Table C13: Displacements ejotherm H1

Base materials	Bulk density ρ [kg/dm ³]	minimum compressive strength f_b [N/mm ²]	Tension load N [kN]	Displacements $\Delta\delta_N$ [mm]
Concrete C 12/15 (EN 206:2013+A1:2016)			0,3	0,6
Concrete C 20/25 – C 50/60 (EN 206:2013+A1:2016)			0,4	0,6
Clay bricks, Mz (EN 771-1:2011+A1:2015)	$\geq 1,8$	12	0,4	0,6
Sand-lime solid bricks, KS (EN 771-2:2011+A1:2015)	$\geq 1,8$	12	0,4	0,6
Vertically perforated clay bricks, HLz (EN 771-1:2011+A1:2015)	$\geq 0,8$	12	0,25	0,3
Sand-lime perforated bricks, KSL (EN 771-2:2011+A1:2015)	$\geq 1,4$	12	0,4	0,4
Lightweight aggregate concrete, LAC (EN 1520:2011 / EN 771-3:2011+A1:2015)	$\geq 1,2$	4	0,37	0,5
Autoclaved aerated concrete (EN 771-4:2011+A1:2015)	$\geq 0,6$	4	0,3	0,4

EJOT H1 eco, EJOT H4 eco, EJOT H6 and ejotherm H1

Performances
Point thermal transmittance, plate stiffness, displacements
ejotherm H1

Annex C 5