

Public-law institution jointly founded by the federal states and the Federation

European Technical Assessment Body
for construction products



European Technical Assessment

ETA-13/0724
of 30 March 2026

English translation prepared by DIBt - Original version in German language

General Part

Technical Assessment Body issuing the European Technical Assessment:

Deutsches Institut für Bautechnik

Trade name of the construction product

WK THERM S

Product family to which the construction product belongs

Plastic anchor for fixing of external thermal insulation composite systems with rendering

Manufacturer

Wkret-met Sp. Z o.o.
Kuznica Kiedrzynska
ul. Wincentego Witosa 170/176
42-233 MYKANÓ
POLAND

Manufacturing plant

Plant 1, Plant 2 Poland

This European Technical Assessment contains

12 pages including 3 annexes which form an integral part of this assessment

This European Technical Assessment is issued in accordance with Article 95(4) of Regulation (EU) No 2024/3110, on the basis of

EAD 330196-01-0604

This version replaces

ETA-13/0724 issued on 9 February 2023

The European Technical Assessment is issued by the Technical Assessment Body in its official language. Translations of this European Technical Assessment in other languages shall fully correspond to the original issued document and shall be identified as such.

Communication of this European Technical Assessment, including transmission by electronic means, shall be in full. However, partial reproduction may only be made with the written consent of the issuing Technical Assessment Body. Any partial reproduction shall be identified as such.

This European Technical Assessment may be withdrawn by the issuing Technical Assessment Body, in particular pursuant to information by the Commission in accordance with Article 36(3) of Regulation (EU) No 2024/3110.

Specific part

1 Technical description of the product

The insulation plug WK THERM S is a screwed-in anchor which consists of a plastic part made of virgin polyethylene and an accompanying specific screw of steel with zinc coating. The anchor may in addition be combined with the anchor plates TDX 90 or TDX 140, according to Annex A 3.

The product description is given in Annex A.

2 Specification of the intended use in accordance with the applicable European Assessment Document

The performances given in Section 3 are only valid if the anchor is used in compliance with the specifications and conditions given in Annex B.

The verifications and assessment methods on which this European Technical Assessment is based lead to the assumption of a working life of the anchor of at least 25 years. The indications given on the working life cannot be interpreted as a guarantee given by the producer, but are to be regarded only as a means for choosing the right products in relation to the expected economically reasonable working life of the works.

3 Performance of the product and references to the methods used for its assessment

3.1 Safety and accessibility in use (BWR 4)

Essential characteristic	Performance
Characteristic load bearing capacity <ul style="list-style-type: none">- Characteristic resistance under tension load- Minimum edge distance and spacing	See Annex C 1 See Annex B 2
Displacements	See Annex C 2
Plate stiffness	See Annex C 2

3.2 Energy economy and heat retention (BWR 6)

Essential characteristic	Performance
Point thermal transmittance	See Annex C 2

4 Assessment and verification of constancy of performance (AVCP) system applied, with reference to its legal base

In accordance with EAD No. 330196-01-0604, the applicable European legal act is: [97/463/EC].
The system to be applied is: 2+

5 Technical details necessary for the implementation of the AVCP system, as provided for in the applicable European Assessment Document

Technical details necessary for the implementation of the AVCP system are laid down in the control plan deposited with Deutsches Institut für Bautechnik.

Issued in Berlin on 30 March 2026 by Deutsches Institut für Bautechnik

Dipl.-Ing. Beatrix Wittstock
Head of Section

beglaubigt:
Ziegler

WK THERM S

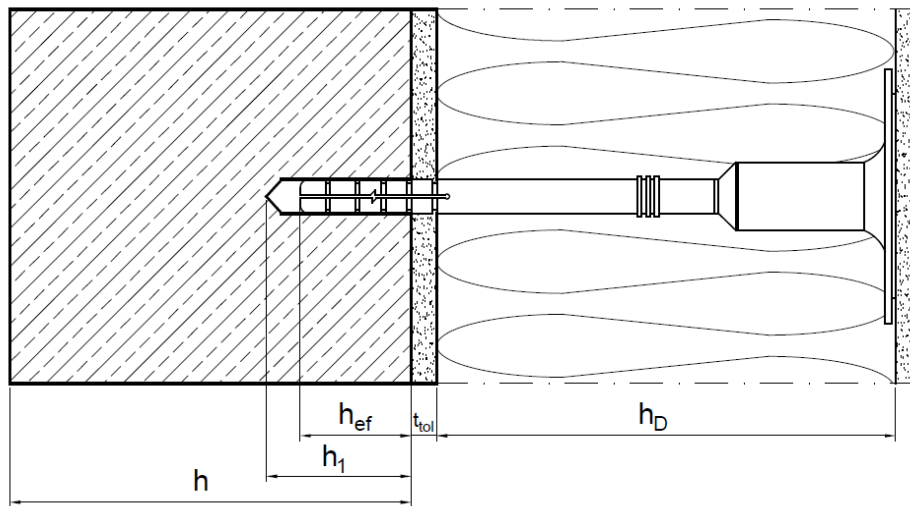

surface mount

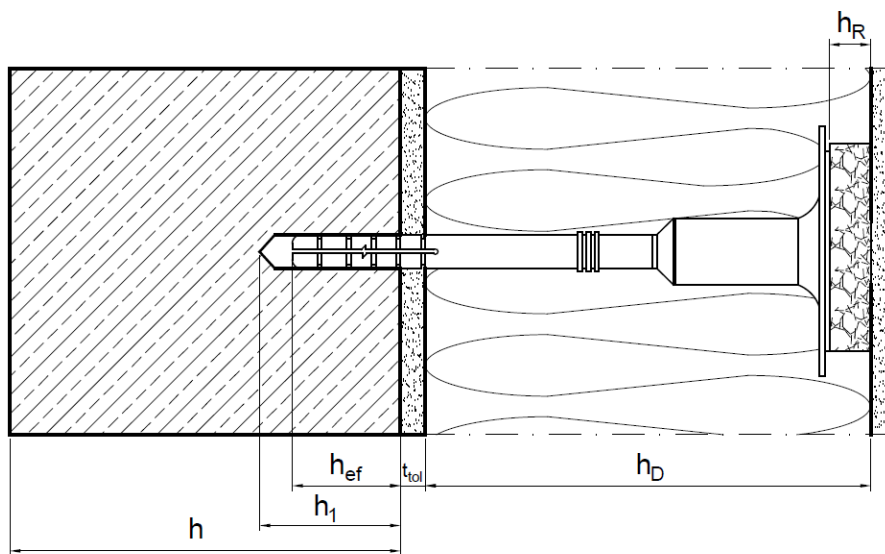

immersed mount

- Legend:
- h_D = thickness of insulation material
 - h_{ef} = effective anchorage depth
 - h = thickness of member (wall)
 - h_1 = depth of drilled hole to deepest point
 - t_{tol} = thickness of equalizing layer or non-load-bearing coating
 - h_R = thickness of insulation cover

WK THERM S

Product description
Installed condition – surface mount, immersed mount

Annex A 1

WK THERM S

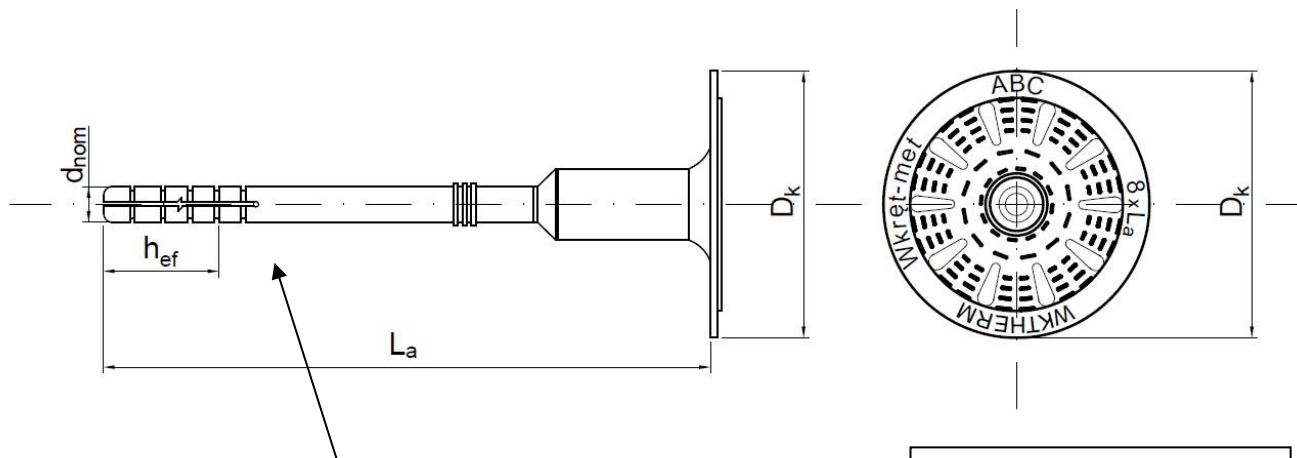

Marking of effective anchorage depth

Marking for anchor sleeve:
Identifying Mark (Wkret-Met)
Anchor sleeve – WK THERM
Anchor size – 8xL_k
Base material group (A B C)

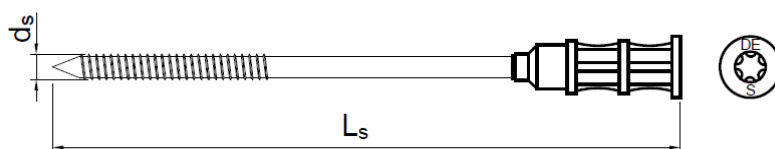

Accompanying specific screw TN-5,1

Marking for specific screw:
Identifying Mark (S)
Base material group (D E)

Table A1: Dimensions

Anchor type	Anchor sleeve					Specific screw		
	D _k [mm]	d _{nom} [mm]	min L _a [mm]	max L _a [mm]	h _{ef} [mm]	d _s [mm]	min L _s [mm]	max L _s [mm]
WK THERM S	60	8	95	355	25/65*	4,55	105	365

* effective anchorage depth for base material group E

Determination of maximum thickness of insulation h_D [mm] for WK THERM S:

$$h_D = L_a - t_{tol} - h_{ef} \quad (\text{e.g. } L_a = 195; t_{tol} = 10)$$

e.g. $h_D = 195 - 10 - 25 = 160$

WK THERM S

Product description
WK THERM S - marking and dimension of the anchor sleeve and specific screw

Annex A 2

Table A2: Materials

Name	Materials
Anchor sleeve	Polyethylene (virgin material), colour nature or grey
Specific screw	Steel with zinc coating $\geq 5 \mu\text{m}$, screw head coated with Polyamide PA6 GF, colour nature or green
Insulation cover	KS: Polystyrene (EPS), colour: white KSG: Polystyrene (EPS), colour: grey

Table A3: Additional slip on plates - diameters and material

Plate type	Outer diameter [mm]	Material
TDX-P-90	90	Polyethylene, nature or grey
TDX-90	90	Polyamide +GF, nature or grey
TDX-P-140	140	Polyethylene, nature or grey
TDX-140	140	Polyamide + GF, nature or grey

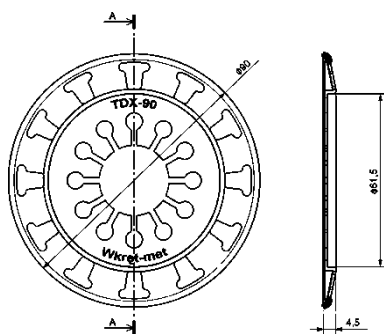

TDX-P-90/TDX-90

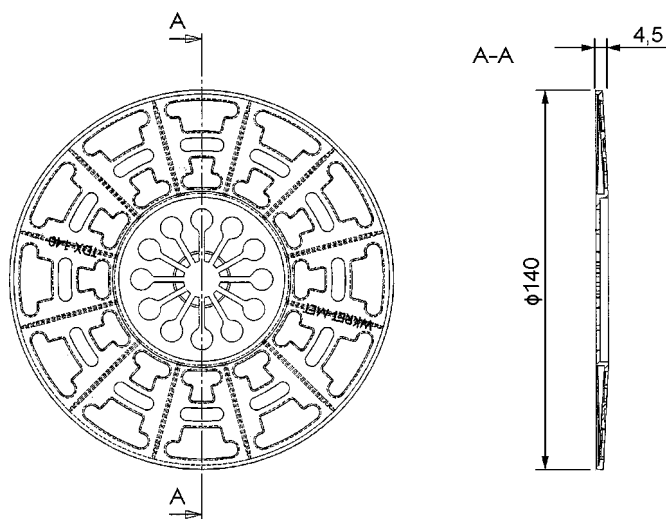

TDX-P-140/TDX-140

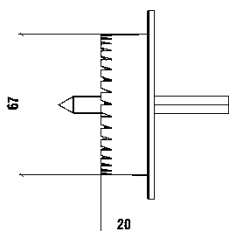

Special drill tool WK-FT for immersed installation

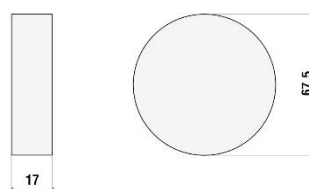

Insulation cover KS and KSG

WK THERM S

Product description
Materials,
Slip on plates with WK THERM S

Annex A 3

Specifications of intended use

Anchorage subject to:

- The anchor may only be used for transmission of wind suction loads and shall not be used for the transmission of dead loads of the thermal insulation composite system.

Base materials:

- Compacted normal weight concrete without fibres (base material group A) according to Annex C 1
- Solid masonry (base material group B), according to Annex C 1
- Hollow or perforated masonry (base material group C), according Annex C 1
- Lightweight aggregate concrete (base material group D), according to Annex C 1
- Autoclaved aerated concrete (base material group E), according to Annex C 1
- For other base materials of the base material groups A, B, C, D or E the characteristic resistance of the anchor may be determined by job site tests according to EOTA Technical Report TR 051 edition April 2018.

Temperature Range:

- 0°C to +40°C (max. short term temperature +40°C and max. long term temperature +24°C)

Design:

- The anchorages are designed under the responsibility of an engineer experienced in anchorages and masonry work with the partial safety factors $\gamma_M = 2,0$ and $\gamma_F = 1,5$ if there are no other national regulations.
- Verifiable calculation notes and drawings are prepared taking account of the loads to be anchored. The position of the anchor is indicated on the design drawings.
- Fasteners are only to be used for multiple fixings of thermal insulation composite systems.

Installation:

- Hole drilling by the drill modes according to Annex C 1
- Anchor installation carried out by appropriately qualified personnel and under the supervision of the person responsible for technical matters of the site.
- Installation temperature from 0°C to +40°C
- Exposure to UV due to solar radiation of the anchor not protected by rendering ≤ 6 weeks

WK THERM S

Intended use
Specifications

Annex B 1

Table B1: Installation parameters for WKTHERM S

		WKTHERM S	WKTHERM S
Base material group		ABCD	E
Drill hole diameter	d_o [mm] =	8	8
Cutting diameter of drill bit	d_{cut} [mm] ≤	8,45	8,45
Depth of drill hole to deepest point	h_1 [mm] ≥	35	75
Effective anchorage depth	h_{ef} [mm] ≥	25	65

Table B2: Anchor distances and dimensions of members

Minimum spacing	$s_{min} \geq$ [mm]	100
Minimum edge distance	$c_{min} \geq$ [mm]	100
Minimum thickness of member	$h \geq$ [mm]	100

Scheme of edge distance and spacing

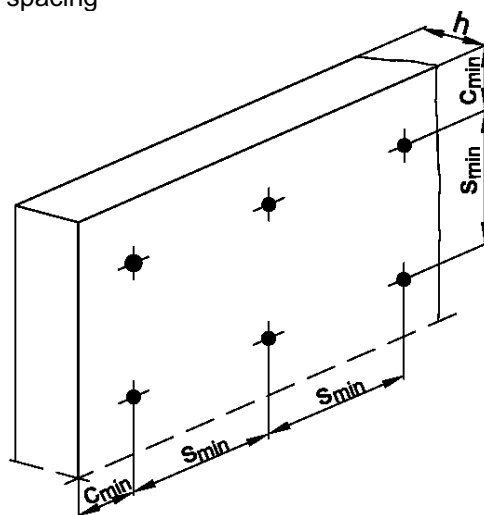

WKTHERM S

Intended use

Installation parameters, minimum thickness of base material
Edge distances and spacing

Annex B 2

Installation instructions

surface mount

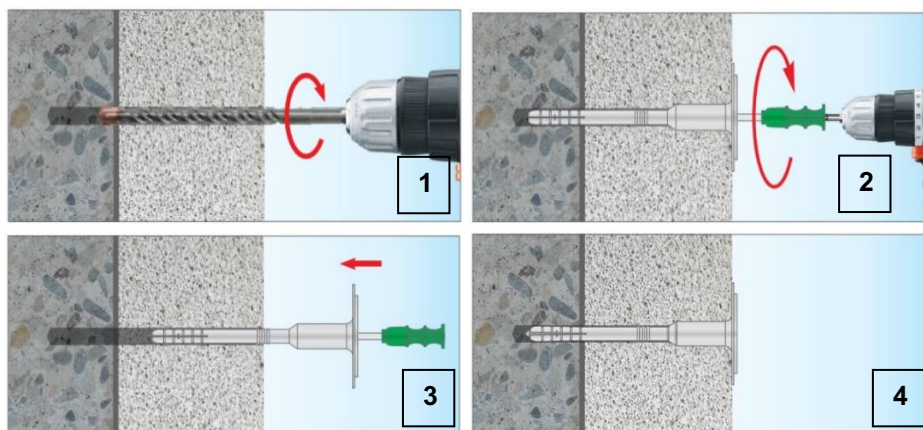

1) Drill the hole perpendicular to the substrate surface. Clean the drill hole.

2) Place the anchor into the drill hole. The bottom side of the plate must be flush with the ETICS.

3) Screw in the specific screw using the screwdriver bits type TX-40

4) Installed condition.

immersed mount

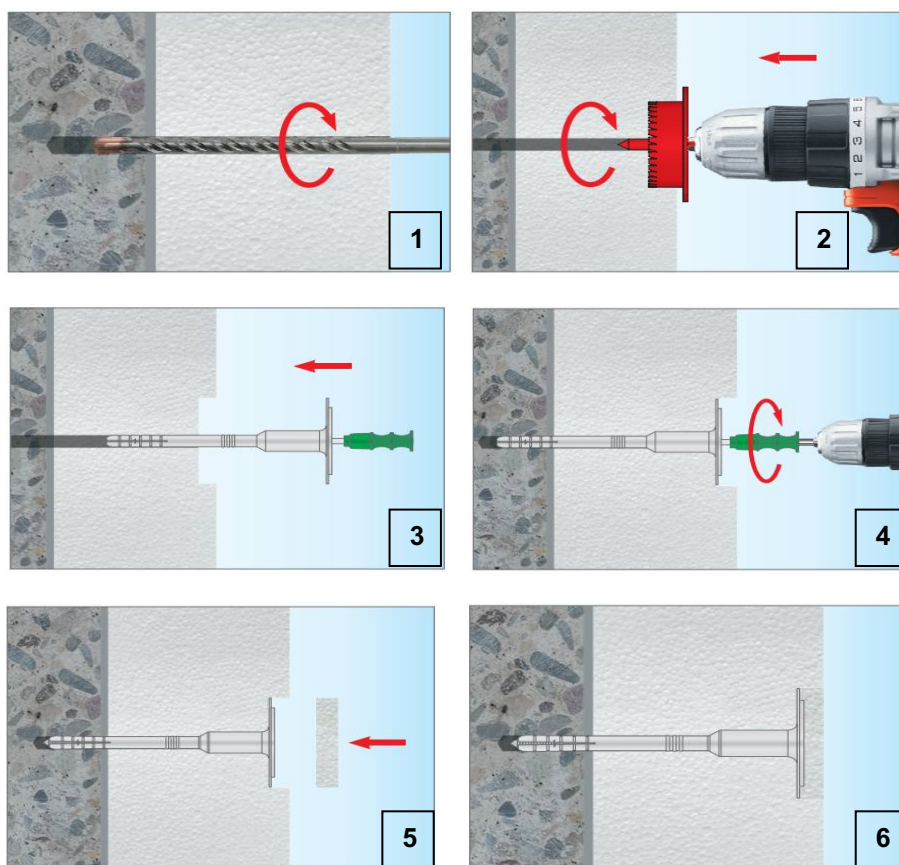

1) Drill the hole perpendicular to the substrate surface. Clean the drill hole.

2) Drill the recess for immersed installation with the special drilling tool WK-FT.

3) Place the anchor into the drill hole. The bottom side of the plate must be flush with the recess in the ETICS.

4) Screw in the specific screw using the screwdriver bits type TX-40

5) Insert the insulation cover.

6) Installed condition.



WK THERM S

Intended use

Installation instructions – surface mount, immersed mount

Annex B 3

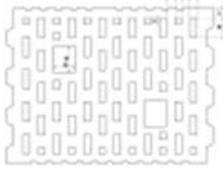
Table C1: Characteristic resistance to tension loads N_{Rk} in concrete and masonry for single anchors in kN

Anchor type				WK THERM S	
Base materials	Bulk density ρ [kg/dm ³]	Compressive strength f_b [N/mm ²]	General remarks	Drill method	N_{Rk} [kN]
Concrete C12/15 as per EN 206:2013+A1:2016	-	-	Concrete without fibres	hammer	1,20
Concrete C16/20 - C50/60 as per EN 206:2013+A1:2016	-	-	Concrete without fibres	hammer	1,50
Clay bricks MZ as per EN 771-1:2011+A1:2015	$\geq 2,0$	≥ 20		hammer	1,50
Calcium silicate bricks KS as per EN 771-2:2011+A1:2015	$\geq 2,0$	≥ 20		hammer	1,50
Calcium silicate hollow block KSL as per EN 771-2:2011+A1:2015 	$\geq 1,6$	≥ 12	Cross section > 15 % and ≤ 50 % reduced by perforation vertically to the resting area, outer web thickness ≥ 20 mm	hammer	0,9
Vertically perforated clay bricks HLZ as per EN 771-1:2011+A1:2015 	$\geq 1,2$	≥ 12	Cross section > 15 % and ≤ 50 % reduced by perforation vertically to the resting area, outer web thickness ≥ 12 mm	rotary	0,75
Lightweight concrete hollow blocks HBL as per EN 771-3:2011+A1:2015 	$\geq 0,8$	≥ 2	Cross section > 15 % and ≤ 50 % reduced by perforation vertically to the resting area, outer web thickness ≥ 30 mm	rotary	0,75
Autoclaved concrete blocks as per EN 771-4:2011+A1:2015	$\geq 0,35$	≥ 2		rotary	0,60
Autoclaved concrete blocks as per EN 771-4:2011+A1:2015	$\geq 0,65$	$\geq 3,5$		rotary	1,20
Lightweight concrete blocks LAC as per EN 1520:2011 / EN 771-3:2011+A1:2015	$\geq 1,05$	≥ 5		rotary	0,90

WK THERM S

Performances

Characteristic resistance

Annex C 1

Table C2: Point thermal transmittance according EOTA Technical Report TR 025:2016-05

anchor type	insulation thickness h_D [mm]	point thermal transmittance χ [W/K]
WK THERM S surface mount	60-320	0,002
WK THERM S immersed mount	60-320	0,002

Table C3: Plate stiffness according EOTA Technical Report TR 026:2016-05

anchor type	diameter of the anchor plate [mm]	load resistance of the anchor plate [kN]	plate stiffness [kN/mm]
WK THERM S	60	4,3	0,6

Table C4: Displacements WK THERM S

Base materials (refer Table C1)	Bulk density ρ [kg/dm ³]	Compressive strength f_b [N/mm ²]	Tension load N [kN]	Displacements $\Delta\delta_N$ [mm]
Concrete C12/15			0,40	3,9
Concrete C16/20 ÷ C50/60			0,50	4,0
Calcium silicate bricks KS	≥ 2,0	≥ 20	0,50	3,2
Clay bricks MZ	≥ 2,0	≥ 20	0,50	3,9
Vertically perforated clay bricks HLZ	≥ 1,2	≥ 12	0,25	4,2
Calcium silicate hollow block KSL	≥ 1,6	≥ 12	0,30	3,5
Lightweight concrete hollow blocks HBL	≥ 0,8	≥ 2	0,25	4,1
Autoclaved concrete blocks	≥ 0,35	≥ 2	0,2	5,0
Autoclaved concrete blocks	≥ 0,65	≥ 3,5	0,4	3,6
Lightweight concrete blocks LAC	≥ 1,05	≥ 5	0,3	3,5

WK THERM S

Performances
Point thermal transmittance, plate stiffness, displacements

Annex C 2