

Public-law institution jointly founded by the  
federal states and the Federation

European Technical Assessment Body  
for construction products



## European Technical Assessment

ETA-15/0167  
of 9 February 2026

English translation prepared by DIBt - Original version in German language

### General Part

Technical Assessment Body issuing the  
European Technical Assessment:

Deutsches Institut für Bautechnik

Trade name of the construction product

DX FAST ETA 1 and DX-I FAST ETA 1

Product family  
to which the construction product belongs

Mechanical fastener for use in concrete

Manufacturer

Ter Laare B.V.  
Postbus 355  
NL-3140 AJ MAASSLUIS  
NIEDERLANDE

Manufacturing plant

Ter Laare Verankeringsstechnieken BV  
Herstellwerk 3

This European Technical Assessment  
contains

36 pages including 3 annexes which form an integral part  
of this assessment

This European Technical Assessment is  
issued in accordance with Article 95(4) of  
Regulation (EU) No 2024/3110, on the basis of

EAD 330232-02-0601

This version replaces

ETA-15/0167 issued on 7 May 2015

The European Technical Assessment is issued by the Technical Assessment Body in its official language. Translations of this European Technical Assessment in other languages shall fully correspond to the original issued document and shall be identified as such.

Communication of this European Technical Assessment, including transmission by electronic means, shall be in full. However, partial reproduction may only be made with the written consent of the issuing Technical Assessment Body. Any partial reproduction shall be identified as such.

This European Technical Assessment may be withdrawn by the issuing Technical Assessment Body, in particular pursuant to information by the Commission in accordance with Article 36(3) of Regulation (EU) No 2024/3110.

## Specific Part

### 1 Technical description of the product

The DX FAST ETA 1 und DX-I FAST ETA 1 is a fastener made of zinc plated steel, stainless steel or high corrosion resistant steel which is placed into a drilled hole and anchored by torque-controlled expansion. The following fastener types are covered:

- Anchor type DX FAST ETA 1 with external thread, washer and hexagon nut, sizes M8 to M27,
- Anchor type DX-I FAST ETA 1 with internal thread, hexagon head nut and washer DIN 933, sizes M6 to M12,
- Anchor type DX-I FAST ETA 1 with internal thread, countersunk head screw and countersunk washer DIN 7991, sizes M6 to M12,
- Anchor type DX-I FAST ETA 1 with internal thread, hexagon nut and washer DIN 976, sizes M6 to M12.

The product description is given in Annex A.

### 2 Specification of the intended use in accordance with the applicable European Assessment Document

The performances given in Section 3 are only valid if the fastener is used in compliance with the specifications and conditions given in Annex B.

The verifications and assessment methods on which this European Technical Assessment is based lead to the assumption of a working life of the fastener of at least 50 years. The indications given on the working life cannot be interpreted as a guarantee given by the producer, but are to be regarded only as a means for choosing the right products in relation to the expected economically reasonable working life of the works.

### 3 Performance of the product and references to the methods used for its assessment

#### 3.1 Mechanical resistance and stability (BWR 1)

Essential characteristic	Performance
Characteristic resistance to tension load (static and quasi-static loading)	DX FAST ETA 1 see Annex B4, B5, C1 to C4 DX-I FAST ETA 1 see Annex B8, C11 and C12
Characteristic resistance to shear load (static and quasi-static loading)	DX FAST ETA 1 see Annex C5 DX-I FAST ETA 1 see Annex C13
Displacements (static and quasi-static loading)	DX FAST ETA 1 see Annex C9 and C10 DX-I FAST ETA 1 see Annex C15
Stiffness	No performance assessed
Characteristic resistance and displacements for seismic performance categories C1 and C2	DX FAST ETA 1 see Annex C6, C9 and C10 DX-I FAST ETA 1 No performance assessed

### 3.2 Safety in case of fire (BWR 2)

Essential characteristic	Performance
Reaction to fire	Class A1
Resistance to fire	DX FAST ETA 1 see Annex C7 and C8 DX-I FAST ETA 1 see Annex C14

### 3.3 Aspects of durability

Essential characteristic	Performance
Durability	See Annex B1

## 4 Assessment and verification of constancy of performance (AVCP) system applied, with reference to its legal base

In accordance with the European Assessment Document EAD 330232-02-0601 the applicable European legal act is: [96/582/EC].

The system to be applied is: 1

## 5 Technical details necessary for the implementation of the AVCP system, as provided for in the applicable European Assessment Document

Technical details necessary for the implementation of the AVCP system are laid down in the control plan deposited with Deutsches Institut für Bautechnik.

Issued in Berlin on 9 February 2026 by Deutsches Institut für Bautechnik

Dipl.-Ing. Beatrix Wittstock  
Head of Section

*beglaubigt:*  
Baderschneider

Fastener version	Product description	Intended use	Performance
DX FAST ETA 1	Annex A1 - Annex A4	Annex B1 – Annex B7	Annex C1 – Annex C10
DX-I FAST ETA 1	Annex A1 Annex A5 – Annex A7	Annex B1 – Annex B2 Annex B8 – Annex B10	Annex C11 – Annex C15

### DX FAST ETA 1

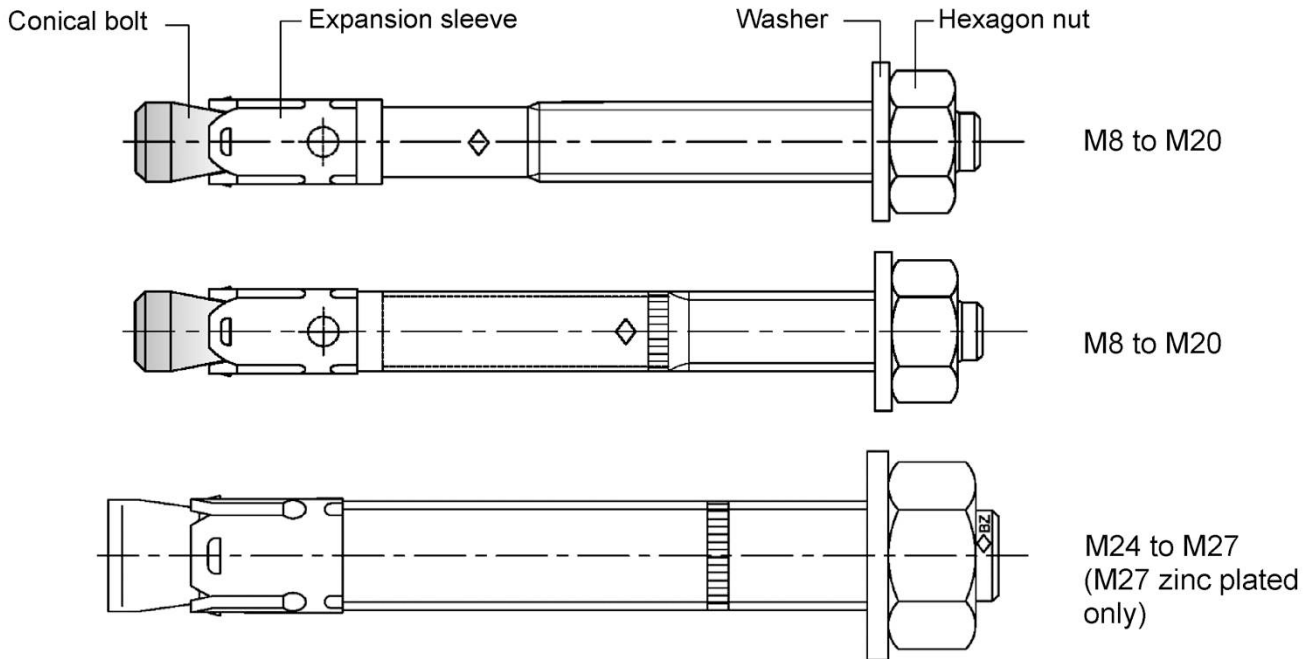

### DX-I FAST ETA 1 M6 to M12

Fastener system			
DX-I FAST ETA 1 + DIN 933	<p>Conical bolt</p> <p>Expansion sleeve</p>	<p>Washer</p>	<p>Hexagon head screw</p>
DX-I FAST ETA 1 + DIN 7991		<p>Countersunk washer</p>	<p>Countersunk head screw</p>
DX-I FAST ETA 1 + DIN 986		<p>Washer</p>	<p>Hexagon nut</p>

DX FAST ETA 1 and DX-I FAST ETA 1

Product description  
Fastener types

Annex A1

### Intended use DX FAST ETA 1

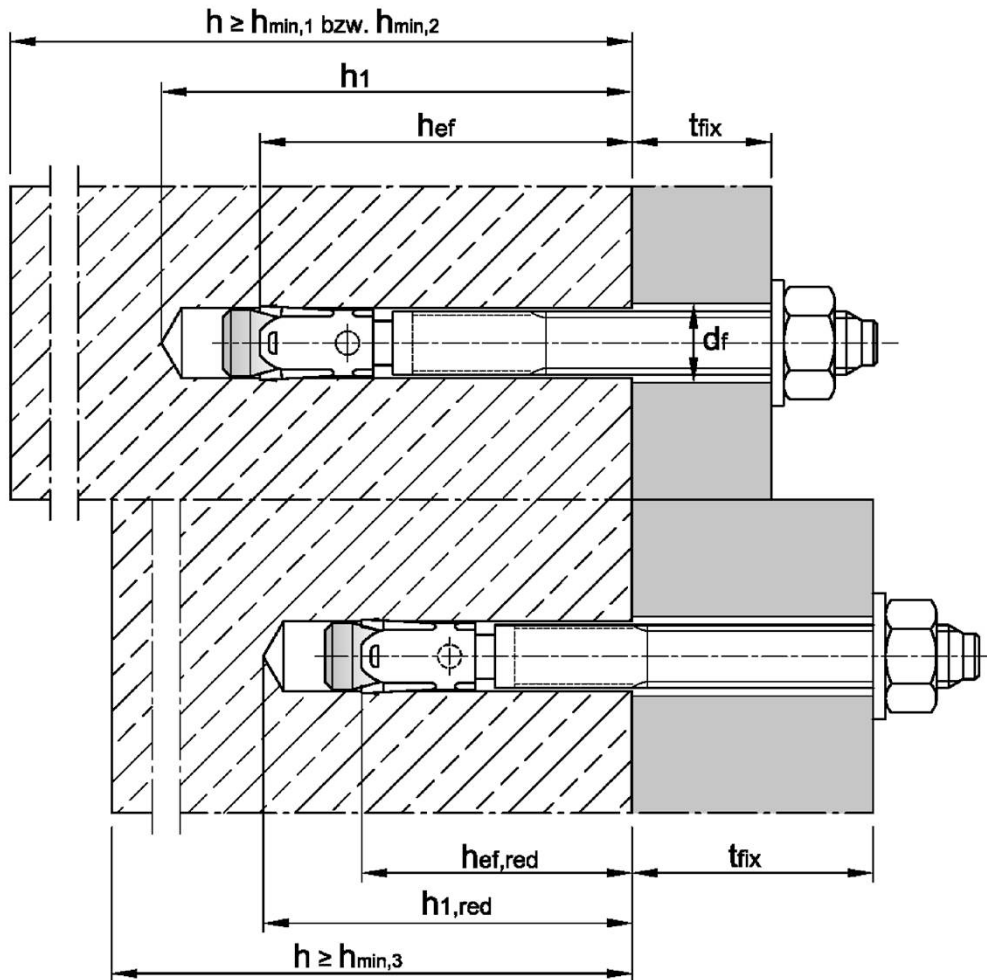

DX FAST ETA 1 and DX-I FAST ETA 1

**Product description**  
Installation situation DX FAST ETA 1

**Annex A2**

**Fastener size DX FAST ETA 1 M8 to M20:**

**Marking 1** e.g.:  $\diamond$  BZ 15/35

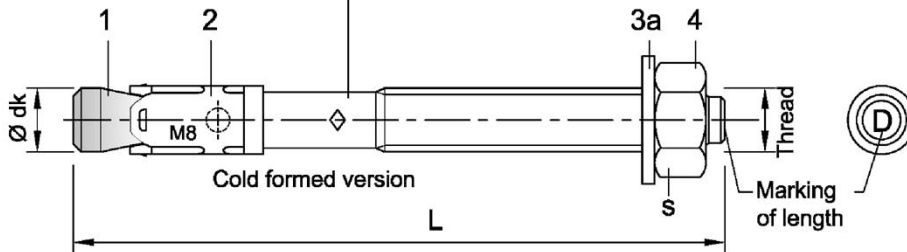

**Marking 1** e.g.:  $\diamond$  BZ 15/35

- $\diamond$  identifying mark of manufacturing plant
- BZ fastener identity
- 15 max. thickness of fixture for  $h_{ef}$
- 35 max. thickness of fixture for  $h_{ef,red}$
- M8 thread diameter
- Additional marking:
- A4 stainless steel
- HCR high corrosion resistant steel

**Marking 2** e.g.:  $\diamond$  BZ 15

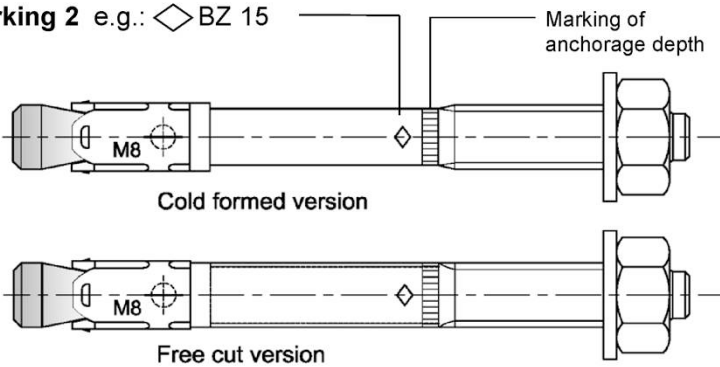

**Marking 2** e.g.:  $\diamond$  BZ 15

- $\diamond$  identifying mark of manufacturing plant
- BZ fastener identity
- 15 maximum thickness of fixture for  $h_{ef}$
- M8 thread diameter
- Additional marking:
- A4 stainless steel
- HCR high corrosion resistant steel

**Fastener size DX FAST ETA 1 M24 and M27:**

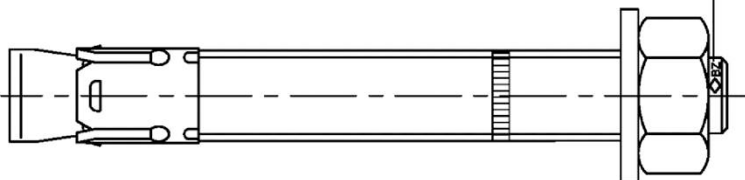

**Marking 3** e.g.:  $\diamond$  BZ M24-30

- $\diamond$  identifying mark of manufacturing plant
- BZ fastener identity
- M24 thread diameter
- 30 maximum thickness of fixture
- Additional marking:
- A4 stainless steel
- HCR high corrosion resistant steel

Marking of length	C (c)	D (d)	E (e)	F (f)	G (g)	H (h)	I (i)	J (j)	K (k)	L (l)	M (m)	N (n)
Length of fastener min $\geq$	63,5	76,2	88,9	101,6	114,3	127,0	139,7	152,4	165,1	177,8	190,5	203,2
Length of fastener max $<$	76,2	88,9	101,6	114,3	127,0	139,7	152,4	165,1	177,8	190,5	203,2	215,9

Marking of length	O (o)	P (p)	Q (q)	R (r)	S (s)	T (t)	U (u)	V (v)	W (w)	X (x)	Y (y)	Z (z)
Length of fastener min $\geq$	215,9	228,6	241,3	254,0	279,4	304,8	330,2	355,6	381,0	406,4	431,8	457,2
Length of fastener max $<$	228,6	241,3	254,0	279,4	304,8	330,2	355,6	381,0	406,4	431,8	457,2	483,0

**Filling washer VR and reducing adapter for filling the annular gap between fastener and fixture**

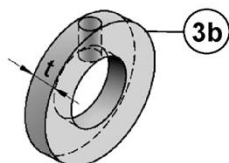

Thickness of washer for diameter  
 $< M24$ :  $t = 5$  mm  
 $\geq M24$ :  $t = 6$  mm

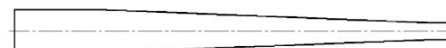

**DX FAST ETA 1 and DX-I FAST ETA 1**

**Product description**  
Fastener sizes and marking

**Annex A3**

**Table A1: Fastener dimensions DX FAST ETA 1**

Fastener size		M8	M10	M12	M16	M20	M24	M27	
Conical bolt	Thread	M8	M10	M12	M16	M20	M24	M27	
	$\varnothing d_k =$	7,9	9,8	12,0	15,7	19,7	24	28	
Length of fastener <sup>1)</sup>	Steel, zinc plated	L	65 + t <sub>fix</sub>	80 + t <sub>fix</sub>	96,5+t <sub>fix</sub>	118+t <sub>fix</sub>	137+t <sub>fix</sub>	161+t <sub>fix</sub>	178+t <sub>fix</sub>
	A4, HCR	L	65 + t <sub>fix</sub>	80 + t <sub>fix</sub>	96,5+t <sub>fix</sub>	118+t <sub>fix</sub>	137+t <sub>fix</sub>	168+t <sub>fix</sub>	-
	reduced anchorage depth	L <sub>hef,red</sub>	54 + t <sub>fix</sub>	60 + t <sub>fix</sub>	76,5+t <sub>fix</sub>	98+t <sub>fix</sub>	-	-	-
Thickness of filling washer		t [mm]	5	5	5	5	6	6	
Hexagon nut		s	13	17	19	24	30	36	41

<sup>1)</sup> With additional use of filling washer 3b the usable thickness of fixture is reduced by the thickness of filling washer t [mm] Dimensions in mm

**Table A2: Materials DX FAST ETA 1**

No.	Part	DX FAST ETA 1		DX FAST ETA 1 A4	DX FAST ETA 1 HCR
		Steel, zinc plated		Stainless steel A4 (CRC III)	High corrosion resistant steel HCR (CRC V)
		galvanized $\geq 5\mu\text{m}$	sherardized $\geq 45\mu\text{m}$		
1	Conical bolt	<u>M8 to M20:</u> Cold formed or machined steel, galvanized, cone plastic coated	<u>M8 to M20:</u> Cold formed or machined steel, sherardized, cone plastic coated	<u>M8 to M20:</u> Stainless steel (e.g. 1.4401, 1.4404, 1.4578, 1.4571) EN 10088:2014, cone plastic coated	<u>M8 to M20:</u> High corrosion resistant steel 1.4529 or 1.4565, EN 10088:2014, cone plastic coated
	Threaded bolt	<u>M24 and M27:</u> Steel, galvanized	<u>M24 and M27:</u> steel, sherardized	<u>M24:</u> Stainless steel (e.g. 1.4401, 1.4404) EN 10088:2014	<u>M24:</u> High corrosion resistant steel 1.4529 or 1.4565, EN 10088:2014
	Threaded cone		<u>M24 and M27:</u> Steel, galvanized		
2	Expansion sleeve	<u>M8 to M20:</u> Steel (e.g. 1.4301 or 1.4401) EN 10088:2014, <u>M24 and M27:</u> Steel, zinc plated	<u>M8 to M20:</u> Steel (e.g. 1.4301 or 1.4401) EN 10088:2014, <u>M24 and M27:</u> Steel, zinc plated	Stainless steel (e.g. 1.4401, 1.4404, 1.4571) EN 10088:2014	Stainless steel (e.g. 1.4401, 1.4404, 1.4571) EN 10088:2014
3a	Washer	Steel, zinc plated	Steel, zinc plated	Stainless steel (e.g. 1.4401, 1.4571) EN 10088:2014	High corrosion resistant steel 1.4529 or 1.4565, EN 10088:2014
3b	Filling washer				
4	Hexagon nut	Steel, galvanized, coated	Steel, zinc plated	Stainless steel (e.g. 1.4401, 1.4571) EN 10088:2014, coated	High corrosion resistant steel 1.4529 or 1.4565, EN 10088:2014, coated

**DX FAST ETA 1 and DX-I FAST ETA 1**

**Product description**  
Dimensions and materials

**Annex A4**

**Intended use DX-I FAST ETA 1**

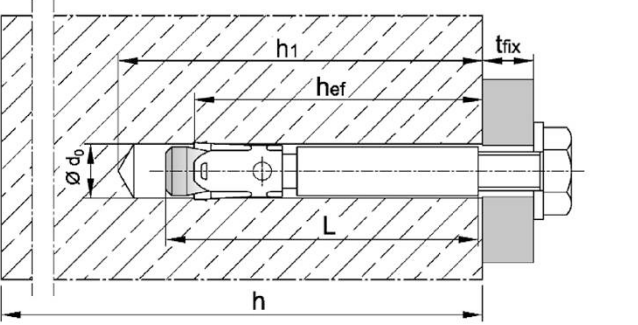
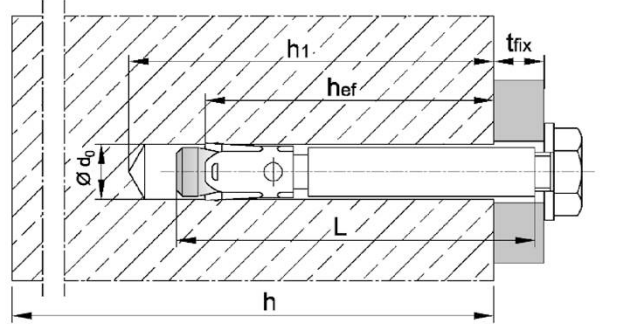
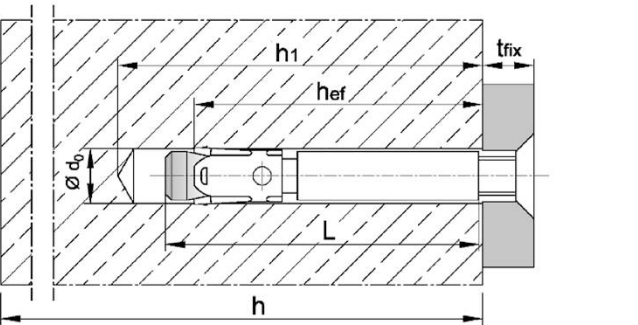
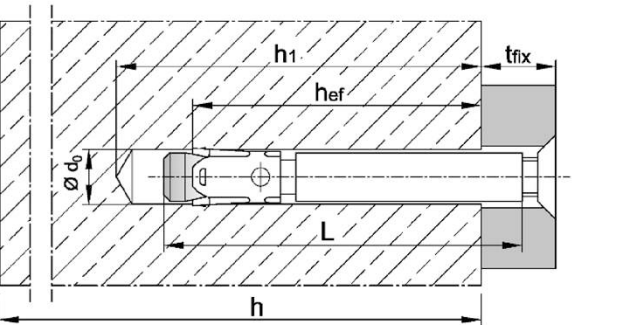
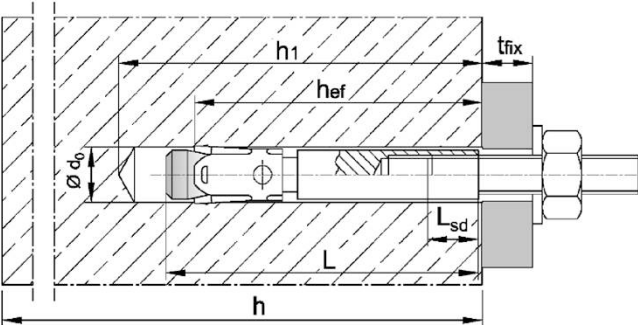
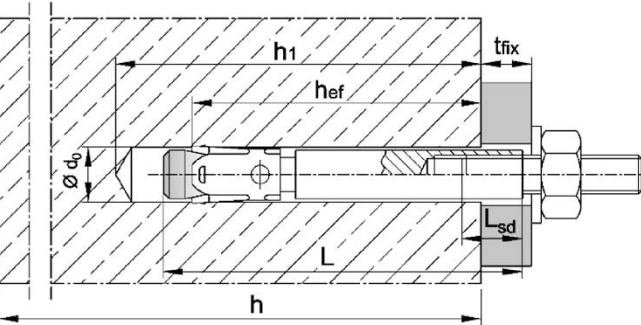
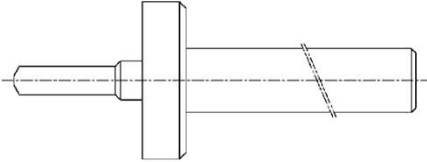
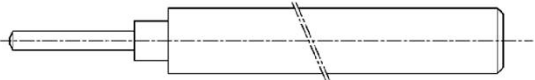
Pre-setting installation (V)	Through-setting installation (D)
Pre-set fastener body DX-I V FAST ETA 1, the fixture bears on the screw or thread rod only	The fastener is set through the fixture, the fixture bears on the conical bolt DX-I D FAST ETA 1
<b>DX-I V+DIN 933</b> consisting of DX-I V+DIN 933	<b>DX-I D+DIN 933</b> consisting of DX-I D+DIN 933
	
<b>DX-I V+DIN 7991</b> consisting of DX-I V+DIN 7991	<b>DX-I D+DIN 7991</b> consisting of DX-I D+DIN 7991
	
<b>DX-I V+DIN 976</b> consisting of DX-I V+DIN 976	<b>DX-I D+DIN 976</b> consisting of DX-I D+DIN 976
	
<b>Setting tool</b>	
	
BZ-IGS M8 V, BZ-IGS M10 V, BZ-IGS M12 V oder BZ-IGS M16 V	BZ-IGS M8 D, BZ-IGS M10 D, BZ-IGS M12 D oder BZ-IGS M16 D
<b>DX FAST ETA 1 and DX-I FAST ETA 1</b>	
<b>Product description</b> Installation situation <b>DX-I FAST ETA 1</b>	<b>Annex A5</b>

**Marking:**  identifying mark of manufacturing plant  
 BZ fastener identity  
 M6 size of internal thread  
 10 max. thickness of fixture  
 (only Through-setting installation)  
**Additional marking:**  
 A4 stainless steel  
 HCR high corrosion resistant steel

e.g.:  BZ M6-10 A4

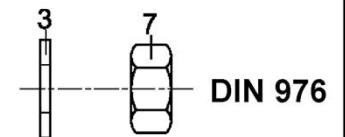
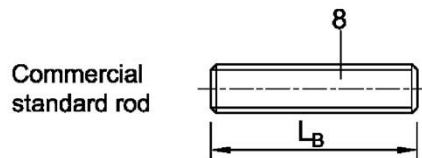
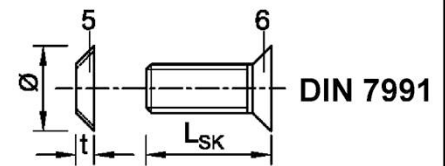
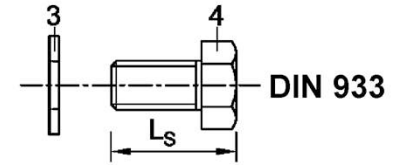
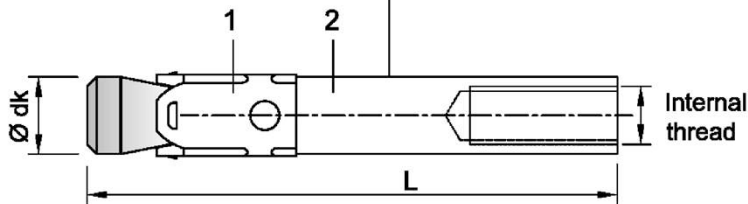

**Table A3: Fastener dimensions DX-I FAST ETA 1**

No.	Fastener size		M6	M8	M10	M12	
1	Conical bolt with internal thread	$\varnothing d_k$	7,9	9,8	11,8	15,7	
		Pre-setting installation	L	50	62	70	86
		Through-setting installation	L	50 + t <sub>fix</sub>	62 + t <sub>fix</sub>	70 + t <sub>fix</sub>	86 + t <sub>fix</sub>
2	Expansion sleeve		see table A4				
3	Washer		see table A4				
4	Hexagon head screw	width across flats	10	13	17	19	
		Pre-setting installation	L <sub>s</sub>	t <sub>fix</sub> + (13 to 21)	t <sub>fix</sub> + (17 to 23)	t <sub>fix</sub> + (21 to 25)	t <sub>fix</sub> + (24 to 29)
		Through-setting installation	L <sub>s</sub>	14 to 20	18 to 22	20 to 22	25 to 28
5	Countersunk washer	$\varnothing$ countersunk	17,3	21,5	25,9	30,9	
		t	3,9	5,0	5,7	6,7	
6	Countersunk head screw	bit size	Torx T30	Torx T45 (Steel, zinc plated) T40 (Stainless steel A4, HCR)	Hexagon socket 6 mm	Hexagon socket 8 mm	
		Pre-setting installation	L <sub>sk</sub>	t <sub>fix</sub> + (11 to 19)	t <sub>fix</sub> + (15 to 21)	t <sub>fix</sub> + (19 to 23)	t <sub>fix</sub> + (21 to 27)
		Through-setting installation	L <sub>sk</sub>	16 to 20	20 to 25	25	30
7	Hexagon nut	width across flats	10	13	17	19	
8	Commercial standard rod <sup>1)</sup>	type V	L <sub>B</sub> ≥	t <sub>fix</sub> + 21	t <sub>fix</sub> + 28	t <sub>fix</sub> + 34	t <sub>fix</sub> + 41
		type D	L <sub>B</sub> ≥	21	28	34	41

<sup>1)</sup> Acc. to specifications (Table A4)

Dimensions in mm

**DX FAST ETA 1 and DX-I FAST ETA 1**

**Product description**  
Fastener parts, marking and dimensions DX-I FAST ETA 1

**Annex A6**

**Table A4: Materials DX-I FAST ETA 1**

No.	Part	DX-I FAST ETA 1	DX-I FAST ETA 1 A4	DX-I FAST ETA 1 HCR
		Steel, galvanized $\geq 5 \mu\text{m}$ acc. to EN ISO 4042:1999	Stainless steel A4 (CRC III)	High corrosion resistant steel HCR (CRC V)
1	Conical bolt DX-I FAST ETA 1 with internal thread	Machined steel, Cone plastic coated	Stainless steel (e.g. 1.4401, 1.4404, 1.4571) EN 10088:2014, Cone plastic coated	High corrosion resistant steel, 1.4529, 1.4565, EN 10088:2014, Cone plastic coated
2	Expansion sleeve DX-I FAST ETA 1	Stainless steel (e.g. 1.4301, 1.4401) EN 10088:2014	Stainless steel (e.g. 1.4401, 1.4571) EN 10088:2014	Stainless steel (e.g. 1.4401, 1.4571) EN 10088:2014
3	Washer DIN 125A	Steel, galvanized	Stainless steel (e.g. 1.4401, 1.4571) EN 10088:2014	High corrosion resistant steel, 1.4529, 1.4565, EN 10088:2014
4	Hexagon head screw DIN 933	Steel, galvanized, coated	Stainless steel (e.g. 1.4401, 1.4571) EN 10088:2014, coated	High corrosion resistant steel, 1.4529, 1.4565, EN 10088:2014, coated
5	Countersunk washer DIN 7991	Steel, galvanized	Stainless steel (e.g. 1.4401, 1.4404, 1.4571) EN 10088:2014, zinc plated, coated	High corrosion resistant steel, 1.4529, 1.4565, EN 10088:2014, zinc plated, coated
6	Countersunk head screw DIN 7991	Steel, galvanized coated	Stainless steel (e.g. 1.4401, 1.4571) EN 10088:2014, coated	High corrosion resistant steel, 1.4529, 1.4565, EN 10088:2014, coated
7	Hexagon nut DIN 976	Steel, galvanized coated	Stainless steel (e.g. 1.4401, 1.4571) EN 10088:2014, coated	High corrosion resistant steel, 1.4529, 1.4565, EN 10088:2014, coated
8	Commercial standard rod	Property class 8.8, EN ISO 898-1:2013 A <sub>5</sub> > 8 % ductile	Stainless steel (e.g. 1.4401, 1.4571) EN 10088:2014, property class 70, EN ISO 3506:2009	High corrosion resistant steel, 1.4529, 1.4565, EN 10088:2014, property class 70, EN ISO 3506:2009

**DX FAST ETA 1 and DX-I FAST ETA 1**

**Product description**  
Materials DX-I FAST ETA 1

**Annex A7**

## Specifications of intended use

DX FAST ETA 1							
Standard anchorage depth	M8	M10	M12	M16	M20	M24	M27
Steel, galvanized				✓			
Steel, sherardized				✓			
Stainless steel A4 and high corrosion resistant steel HCR			✓				_{2)}
Static or quasi-static action				✓			
Fire exposure				✓			
Seismic action (C1 and C2) <sup>1)</sup>			✓			_{2)}	_{2)}
Reduced anchorage depth <sup>1)</sup>	M8	M10	M12	M16			
Steel, galvanized			✓				
Steel, sherardized			✓				
Stainless steel A4 and high corrosion resistant steel HCR			✓				
Static or quasi-static action			✓				
Fire exposure			✓				
Seismic action (C1 and C2)			_{2)}				

<sup>1)</sup> Only cold formed anchors acc. to Annex A3

<sup>2)</sup> No performance assessed

DX-I FAST ETA 1	M6	M8	M10	M12
Steel, galvanized			✓	
Stainless steel A4 and high corrosion resistant steel HCR			✓	
Static or quasi-static action			✓	
Fire exposure			✓	
Seismic action (C1 and C2)			_{1)}	

<sup>1)</sup> No performance assessed

### Base materials:

- Compacted, reinforced or unreinforced normal weight concrete (without fibers) according to EN 206:2013+A2:2021
- Strength classes C20/25 to C50/60 according to EN 206:2013+A2:2021
- Cracked or uncracked concrete

### Use conditions (Environmental conditions):

- Structures subject to dry internal conditions: all materials
- For all other conditions: Intended use of materials according to Annex A4, Table A2 or Annex A7, Table A4 corresponding corrosion resistance classes CRC according to EN 1993-1-4:2006+A1:2015

## DX FAST ETA 1 and DX-I FAST ETA 1

Intended use  
Specifications

Annex B1

## Specifications of intended use

### Design:

- Anchorages are designed under the responsibility of an engineer experienced in anchorages and concrete work
- Verifiable calculation notes and drawings are prepared taking account of the loads to be anchored. The position of the fastener is indicated on the design drawings (e.g. position of the fastener relative to reinforcement or to supports, etc.).
- Dimensioning of fasteners under static or quasi-static action, seismic action or fire exposure according to EN 1992-4:2018 in conjunction with Technical Report TR 055, Edition February 2018

### Installation:

- Fastener installation carried out by appropriately qualified personnel and under the supervision of the person responsible for technical matters of the site
- Hole drilling by hammer drill bit or vacuum drill bit
- Use of the fastener only as supplied by the manufacturer without exchanging the components of the fastener
- Optionally, the annular gap between fixture and stud of the DX FAST ETA 1 can be filled to reduce the hole. For this purpose, the filling washer (3b) must be used in addition to the supplied washer (3a). For filling use high-strength mortar with compressive strength  $\geq 40 \text{ N/mm}^2$ .
- In case of aborted hole: new drilling at a minimum distance away of twice the depth of the aborted hole or smaller distance if the aborted drill hole is filled with high strength mortar and if under shear or oblique tension load it is not in the direction of load application

**DX FAST ETA 1 and DX-I FAST ETA 1**

**Intended use  
Specifications**

**Annex B2**

**Table B1: Installation parameters, DX FAST ETA 1**

Fastener size			M8	M10	M12	M16	M20	M24	M27	
Nominal drill hole diameter	$d_0$	[mm]	8	10	12	16	20	24	28	
Cutting diameter of drill bit	$d_{cut} \leq$	[mm]	8,45	10,45	12,5	16,5	20,55	24,55	28,55	
Installation torque	Steel, galvanized	$T_{inst}$	[Nm]	20	25	45	90	160	200	300
	Steel, sherardized	$T_{inst}$	[Nm]	16	22	40	90	160	260	300
	Stainless steel A4, HCR	$T_{inst}$	[Nm]	20	35	50	110	200	290	- <sup>1)</sup>
Diameter of clearance hole in the fixture	$d_f \leq$	[mm]	9	12	14	18	22	26	30	
<b>Standard anchorage depth</b>										
Depth of drill hole	Steel, zinc plated	$h_1 \geq$	[mm]	60	75	90	110	125	145	160
	Stainless steel A4, HCR	$h_1 \geq$	[mm]	60	75	90	110	125	155	- <sup>1)</sup>
Effective anchorage depth	Steel, zinc plated	$h_{ef}$	[mm]	46	60	70	85	100	115	125
	Stainless steel A4, HCR	$h_{ef}$	[mm]	46	60	70	85	100	125	- <sup>1)</sup>
<b>Reduced anchorage depth</b>										
Depth of drill hole	$h_{1,red} \geq$	[mm]	49	55	70	90	- <sup>1)</sup>	- <sup>1)</sup>	- <sup>1)</sup>	
Reduced effective anchorage depth	$h_{ef,red}$	[mm]	35	40	50	65	- <sup>1)</sup>	- <sup>1)</sup>	- <sup>1)</sup>	

<sup>1)</sup> No performance assessed

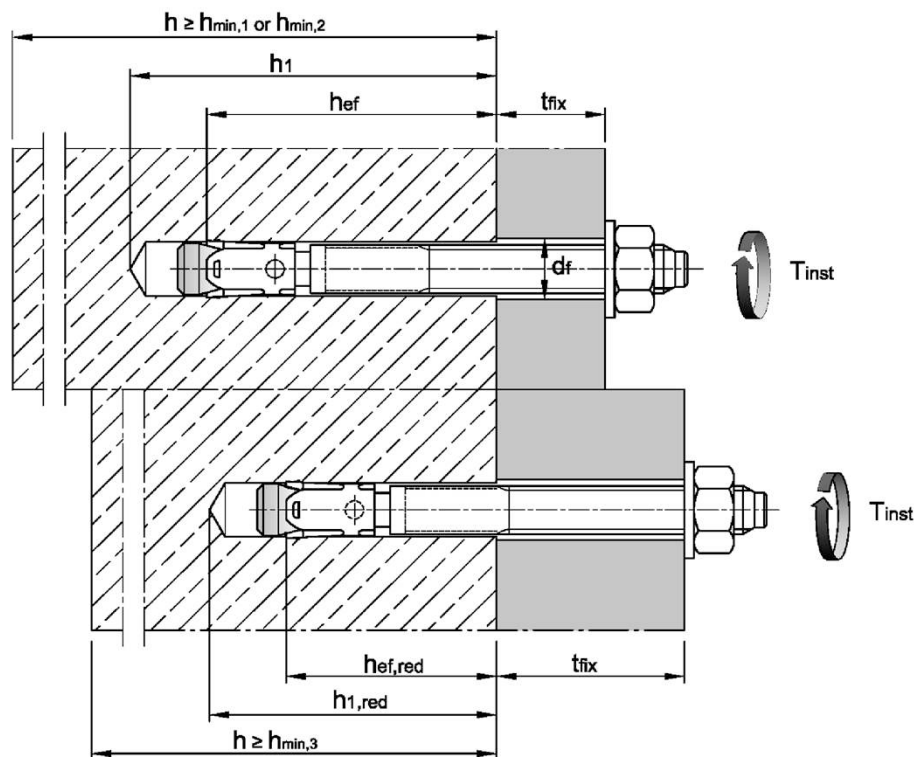

**DX FAST ETA 1 and DX-I FAST ETA 1**

**Intended use**  
Installation parameters

**Annex B3**

**Table B2: Minimum spacings and edge distances, standard anchorage depth,  
DX FAST ETA 1**

Fastener size		M8	M10	M12	M16	M20	M24	M27
<b>Standard thickness of concrete member</b>								
<b>Steel zinc plated</b>								
Standard thickness of member	$h_{min,1}$ [mm]	100	120	140	170	200	230	250
<b>Cracked concrete</b>								
Minimum spacing	$s_{min}$ [mm]	40	45	60	60	95	100	125
	für $c \geq$ [mm]	70	70	100	100	150	180	300
Minimum edge distance	$c_{min}$ [mm]	40	45	60	60	95	100	180
	für $s \geq$ [mm]	80	90	140	180	200	220	540
<b>Uncracked concrete</b>								
Minimum spacing	$s_{min}$ [mm]	40	45	60	65	90	100	125
	für $c \geq$ [mm]	80	70	120	120	180	180	300
Minimum edge distance	$c_{min}$ [mm]	50	50	75	80	130	100	180
	für $s \geq$ [mm]	100	100	150	150	240	220	540
<b>Stainless steel A4, HCR</b>								
Standard thickness of member	$h_{min,1}$ [mm]	100	120	140	160	200	250	- <sup>1)</sup>
<b>Cracked concrete</b>								
Minimum spacing	$s_{min}$ [mm]	40	50	60	60	95	125	- <sup>1)</sup>
	für $c \geq$ [mm]	70	75	100	100	150	125	
Minimum edge distance	$c_{min}$ [mm]	40	55	60	60	95	125	
	für $s \geq$ [mm]	80	90	140	180	200	125	
<b>Uncracked concrete</b>								
Minimum spacing	$s_{min}$ [mm]	40	50	60	65	90	125	- <sup>1)</sup>
	für $c \geq$ [mm]	80	75	120	120	180	125	
Minimum edge distance	$c_{min}$ [mm]	50	60	75	80	130	125	
	für $s \geq$ [mm]	100	120	150	150	240	125	
<b>Minimum thickness of concrete member</b>								
<b>Steel zinc plated, stainless steel A4, HCR</b>								
Minimum thickness of member	$h_{min,2}$ [mm]	80	100	120	140	- <sup>1)</sup>	- <sup>1)</sup>	- <sup>1)</sup>
<b>Cracked concrete</b>								
Minimum spacing	$s_{min}$ [mm]	40	45	60	70	- <sup>1)</sup>	- <sup>1)</sup>	- <sup>1)</sup>
	für $c \geq$ [mm]	70	90	100	160			
Minimum edge distance	$c_{min}$ [mm]	40	50	60	80			
	für $s \geq$ [mm]	80	115	140	180			
<b>Uncracked concrete</b>								
Minimum spacing	$s_{min}$ [mm]	40	60	60	80	- <sup>1)</sup>	- <sup>1)</sup>	- <sup>1)</sup>
	für $c \geq$ [mm]	80	140	120	180			
Minimum edge distance	$c_{min}$ [mm]	50	90	75	90			
	für $s \geq$ [mm]	100	140	150	200			
<b>Fire exposure from one side</b>								
Minimum spacing	$s_{min,fi}$ [mm]	See normal ambient temperature						
Minimum edge distance	$c_{min,fi}$ [mm]	See normal ambient temperature						
<b>Fire exposure from more than one side</b>								
Minimum spacing	$s_{min,fi}$ [mm]	See normal ambient temperature						
Minimum edge distance	$c_{min,fi}$ [mm]	$\geq 300$ mm						

Intermediate values by linear interpolation.

<sup>1)</sup> No performance assessed

**DX FAST ETA 1 and DX-I FAST ETA 1**

**Intended use**  
Minimum spacings and edge distances for standard anchorage depth

**Annex B4**

**Table B3: Minimum spacings and edge distances, reduced anchorage depth,  
DX FAST ETA 1**

Fastener size		M8	M10	M12	M16
Minimum thickness of concrete member	$h_{min,3}$ [mm]	80	80	100	140
<b>Cracked concrete</b>					
Minimum spacing	$s_{min}$ [mm]	50	50	50	65
	für $c \geq$ [mm]	60	100	160	170
Minimum edge distance	$c_{min}$ [mm]	40	65	65	100
	für $s \geq$ [mm]	185	180	250	250
<b>Uncracked concrete</b>					
Minimum spacing	$s_{min}$ [mm]	50	50	50	65
	für $c \geq$ [mm]	60	100	160	170
Minimum edge distance	$c_{min}$ [mm]	40	65	100	170
	für $s \geq$ [mm]	185	180	185	65
<b>Fire exposure from one side</b>					
Minimum spacing	$s_{min,fi}$ [mm]	See normal ambient temperature			
Minimum edge distance	$c_{min,fi}$ [mm]	See normal ambient temperature			
<b>Fire exposure from more than one side</b>					
Minimum spacing	$s_{min,fi}$ [mm]	See normal ambient temperature			
Minimum edge distance	$c_{min,fi}$ [mm]	$\geq 300$ mm			

Intermediate values by linear interpolation.

**DX FAST ETA 1 and DX-I FAST ETA 1**

**Intended use**  
Minimum spacings and edge distances for reduced anchorage depth

**Annex B5**

### Installation instructions DX FAST ETA 1

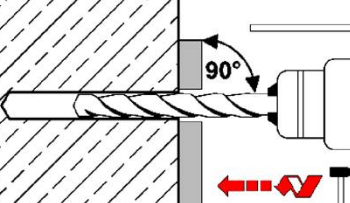
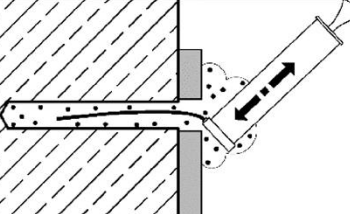
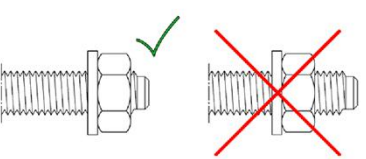
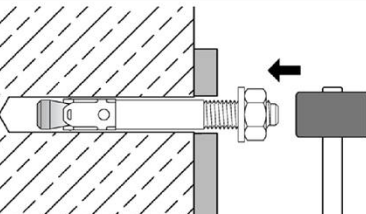
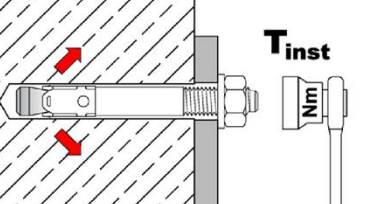
1		<p>Drill hole perpendicular to concrete surface. If using a vacuum drill bit, proceed with step 3.</p>
2		<p>Blow out dust. Alternatively vacuum clean down to the bottom of the hole.</p>
3		<p>Check position of nut.</p>
4		<p>Drive in fastener, such that <math>h_{ef}</math> or <math>h_{ef,red}</math> depth is met. This compliance is ensured, if the thickness of fixture is not greater than the maximum thickness of fixture marked on the fastener in accordance with Annex A3.</p>
5		<p>Installation torque <math>T_{inst}</math> shall be applied by using calibrated torque wrench.</p>

DX FAST ETA 1 and DX-I FAST ETA 1

Intended Use  
Installation instructions

Annex B6

### Installation instructions DX FAST ETA 1 with filling of annular gap

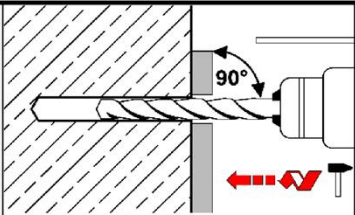
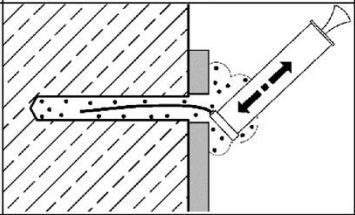
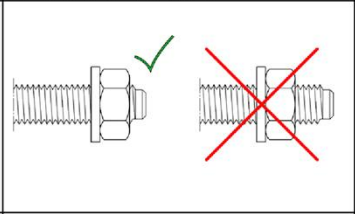
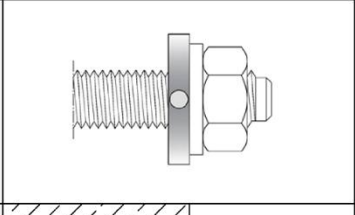
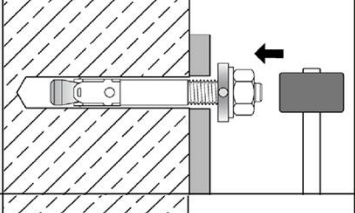
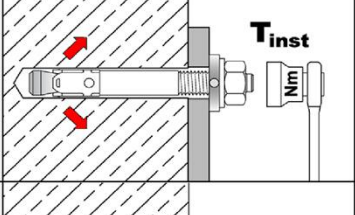
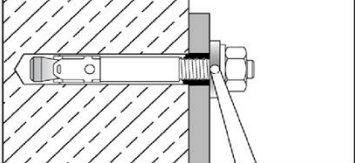
1		<p>Drill hole perpendicular to concrete surface. If using a vacuum drill bit, proceed with step 3a.</p>
2		<p>Blow out dust. Alternatively vacuum clean down to the bottom of the hole.</p>
3a		<p>Check position of nut.</p>
3b		<p>Fit the filling washer to the fastener. The thickness of the filling washer must be taken into account with <math>t_{fix}</math>.</p>
4		<p>Drive in fastener with filling washer, such that <math>h_{ef}</math> or <math>h_{ef,red}</math> depth is met. This compliance is ensured, if the thickness of fixture is 5mm smaller (or 6mm when <math>\geq M24</math>) than the maximum thickness of fixture marked on the fastener in accordance with Annex A3.</p>
5		<p>Installation torque <math>T_{inst}</math> shall be applied by using calibrated torque wrench.</p>
6		<p>Fill the annular gap between stud and fixture with high strength mortar with compressive strength <math>\geq 40 \text{ N/mm}^2</math>. Use enclosed reducing adapter. Observe the processing information of the mortar! The annular gap is completely filled, when excess mortar seeps out.</p>

DX FAST ETA 1 and DX-I FAST ETA 1

**Intended Use**  
Installation instructions with filling washer

**Annex B7**

**Table B4: Installation parameters DX-I FAST ETA 1**

Fastener size			M6	M8	M10	M12	
Effective anchorage depth	$h_{ef}$	[mm]	45	58	65	80	
Drill hole diameter	$d_0$	[mm]	8	10	12	16	
Cutting diameter of drill bit	$d_{cut} \leq$	[mm]	8,45	10,45	12,5	16,5	
Depth of drill hole	$h_1 \geq$	[mm]	60	75	90	105	
Screwing depth of threaded rod	$L_{sd}^{2)} \geq$	[mm]	9	12	15	18	
Installation torque, steel zinc plated	$T_{inst}$	DX-I+DIN 933	[Nm]	10	30	30	55
		DX-I+DIN 7991	[Nm]	10	25	40	50
		DX-I+DIN 976	[Nm]	8	25	30	45
Installation torque, stainless steel A4, HCR	$T_{inst}$	DX-I+DIN 933	[Nm]	15	40	50	100
		DX-I+DIN 7991	[Nm]	12	25	45	60
		DX-I+DIN 976	[Nm]	8	25	40	80
<b>Pre-setting installation</b>							
Diameter of clearance hole in the fixture	$d_f \leq$	[mm]	7	9	12	14	
Minimum thickness of fixture	$t_{fix} \geq$	DX-I+DIN 933	[mm]	1	1	1	1
		DX-I+DIN 7991	[mm]	5	7	8	9
		DX-I+DIN 976	[mm]	1	1	1	1
<b>Through-setting installation</b>							
Diameter of clearance hole in the fixture	$d_f \leq$	[mm]	9	12	14	18	
Minimum thickness of fixture <sup>1)</sup>	$t_{fix} \geq$	DX-I+DIN 933	[mm]	5	7	8	9
		DX-I+DIN 7991	[mm]	9	12	14	16
		DX-I+DIN 976	[mm]	5	7	8	9

<sup>1)</sup> The minimum thickness of fixture can be reduced to the value of pre-setting installation, if the shear load at steel failure is designed with lever arm.

<sup>2)</sup> see Annex A5

**Table B5: Minimum spacings and edge distances DX-I FAST ETA 1**

Fastener size			M6	M8	M10	M12
Minimum thickness of concrete member	$h_{min}$	[mm]	100	120	130	160
<b>Cracked concrete</b>						
Minimum spacing	$s_{min}$	[mm]	50	60	70	80
	für $c \geq$	[mm]	60	80	100	120
Minimum edge distance	$c_{min}$	[mm]	50	60	70	80
	für $s \geq$	[mm]	75	100	100	120
<b>Uncracked concrete</b>						
Minimum spacing	$s_{min}$	[mm]	50	60	65	80
	für $c \geq$	[mm]	80	100	120	160
Minimum edge distance	$c_{min}$	[mm]	50	60	70	100
	für $s \geq$	[mm]	115	155	170	210
<b>Fire exposure from one side</b>						
Minimum spacing	$s_{min,fi}$	[mm]	See normal temperature			
Minimum edge distance	$c_{min,fi}$	[mm]	See normal temperature			
<b>Fire exposure from more than one side</b>						
Minimum spacing	$s_{min,fi}$	[mm]	See normal temperature			
Minimum edge distance	$c_{min,fi}$	[mm]	$\geq 300$ mm			

Intermediate values by linear interpolation.

**DX FAST ETA 1 and DX-I FAST ETA 1**

**Intended use**

Installation parameters, minimum spacings and edge distances DX-I FAST ETA 1

**Annex B8**

## Installation instructions DX-I FAST ETA 1

### Pre-setting installation

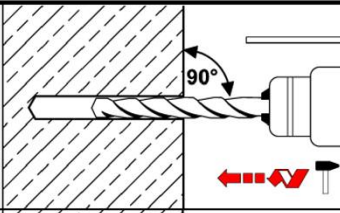
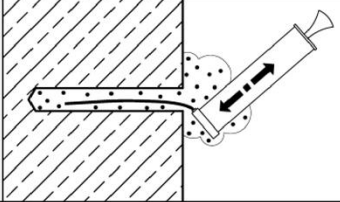
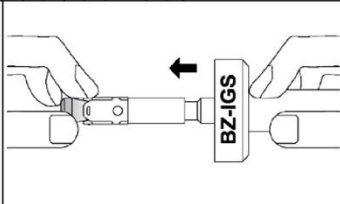
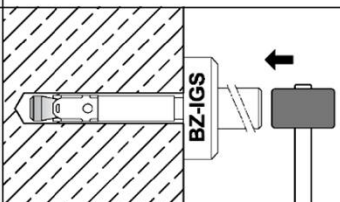
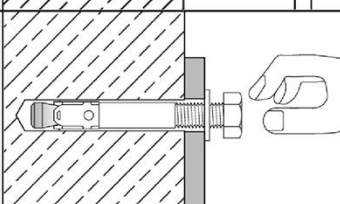
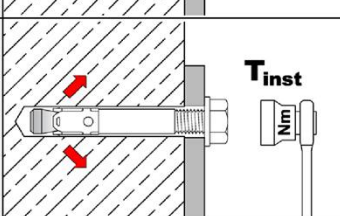
1		<p>Drill hole perpendicular to concrete surface. If using vacuum drill bit, proceed with step 3.</p>
2		<p>Blow out dust. Alternatively vacuum clean down to the bottom of the hole.</p>
3		<p>Setting tool for <b>pre-setting installation</b> insert in fastener.</p>
4		<p>Drive in fastener with setting tool.</p>
5		<p>Drive in screw.</p>
6		<p>Installation torque <math>T_{inst}</math> may be applied by using calibrated torque wrench.</p>

DX FAST ETA 1 and DX-I FAST ETA 1

**Intended Use**  
Installation instructions for pre-setting installation DX-I FAST ETA 1

**Annex B9**

## Installation instructions DX-I FAST ETA 1

### Through-setting installation

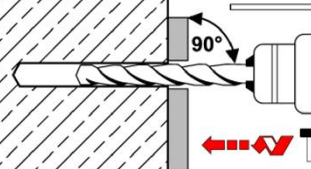
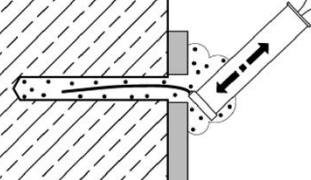
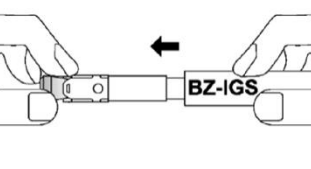
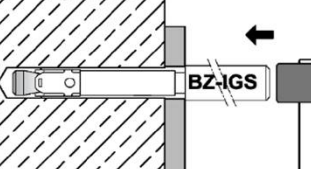
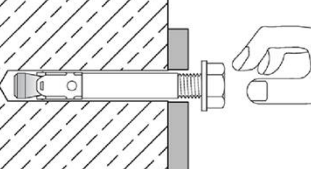
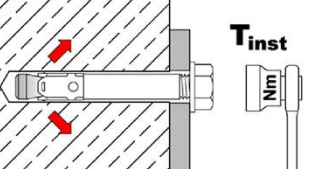
1		<p>Drill hole perpendicular to concrete surface. If using a vacuum drill bit, proceed with step 3.</p>
2		<p>Blow out dust. Alternatively vacuum clean down to the bottom of the hole.</p>
3		<p>Setting tool for <b>through-setting installation</b> insert in fastener.</p>
4		<p>Drive in fastener with setting tool.</p>
5		<p>Drive in screw.</p>
6		<p>Installation torque <math>T_{inst}</math> may be applied by using calibrated torque wrench.</p>

DX FAST ETA 1 and DX-I FAST ETA 1

**Intended Use**  
Installation instructions for through-setting installation DX-I FAST ETA 1

**Annex B10**

**Table C1: Characteristic values for tension loads, DX FAST ETA 1, (zinc plated), cracked concrete, static and quasi-static action**

Fastener size			M8	M10	M12	M16	M20	M24	M27
Installation factor	$\gamma_{inst}$	[-]	1,0						
<b>Steel failure</b>									
Characteristic resistance	$N_{Rk,s}$	[kN]	16	27	40	60	86	126	196
Partial factor	$\gamma_{Ms}$	[-]	1,53		1,5		1,6	1,5	
<b>Pull-out</b>									
<b>Standard anchorage depth</b>									
Characteristic resistance in cracked concrete C20/25	$N_{Rk,p}$	[kN]	5	9	16	25	36	44,4	50,3
<b>Reduced anchorage depth</b>									
Characteristic resistance in cracked concrete C20/25	$N_{Rk,p}$	[kN]	5	7,5	12,7	18,9	- <sup>1)</sup>	- <sup>1)</sup>	- <sup>1)</sup>
Increasing factor for $N_{Rk,p} = \psi_c \cdot N_{Rk,p} (C20/25)$	$\psi_c$	[-]	$\left(\frac{f_{ck}}{20}\right)^{0,5}$						
<b>Concrete cone failure</b>									
Effective anchorage depth	$h_{ef}$	[mm]	46	60	70	85	100	115	125
Reduced anchorage depth	$h_{ef,red}$	[mm]	35 <sup>2)</sup>	40	50	65	- <sup>1)</sup>	- <sup>1)</sup>	- <sup>1)</sup>
Factor for cracked concrete	$k_{cr,N}$	[-]	7,7						

<sup>1)</sup> No performance assessed

<sup>2)</sup> Restricted to the use of structural components with  $h_{ef} < 40\text{mm}$  which are statically indeterminate and subject to dry internal exposure conditions only

**DX FAST ETA 1 and DX-I FAST ETA 1**

**Performance**  
Characteristic values for **tension loads, DX FAST ETA 1 (zinc plated), cracked concrete**, static and quasi-static action

**Annex C1**

**Table C2: Characteristic values for tension loads, DX FAST ETA 1 (A4 / HCR), cracked concrete, static and quasi-static action**

Fastener size		M8	M10	M12	M16	M20	M24
Installation factor	$\gamma_{inst}$ [-]	1,0					
<b>Steel failure</b>							
Characteristic resistance	$N_{Rk,s}$ [kN]	16	27	40	64	108	110
Partial factor	$\gamma_{Ms}$ [-]	1,5				1,68	1,5
<b>Pull-out</b>							
<b>Standard anchorage depth</b>							
Characteristic resistance in cracked concrete C20/25	$N_{Rk,p}$ [kN]	5	9	16	25	36	40
<b>Reduced anchorage depth</b>							
Characteristic resistance in cracked concrete C20/25	$N_{Rk,p}$ [kN]	5	7,5	12,7	18,9	- <sup>1)</sup>	- <sup>1)</sup>
Increasing factor for $N_{Rk,p} = \psi_c \cdot N_{Rk,p} (C20/25)$	$\psi_c$ [-]	$\left(\frac{f_{ck}}{20}\right)^{0,5}$					
<b>Concrete cone failure</b>							
Effective anchorage depth	$h_{ef}$ [mm]	46	60	70	85	100	125
Reduced anchorage depth	$h_{ef,red}$ [mm]	35 <sup>2)</sup>	40	50	65	- <sup>1)</sup>	- <sup>1)</sup>
Factor for cracked concrete	$k_{cr,N}$ [-]	7,7					

<sup>1)</sup> No performance assessed.

<sup>2)</sup> Restricted to the use of structural components with  $h_{ef} < 40\text{mm}$  which are statically indeterminate and subject to dry internal exposure conditions only

**DX FAST ETA 1 and DX-I FAST ETA 1**

**Performance**

Characteristic values for **tension loads, DX FAST ETA 1 (A4 / HCR), cracked concrete**, static and quasi-static action

**Annex C2**

**Table C3: Characteristic values for tension loads, DX FAST ETA 1 (zinc plated), uncracked concrete, static and quasi-static action**

Fastener size		M8	M10	M12	M16	M20	M24	M27	
Installation factor	$\gamma_{inst}$ [-]	1,0							
<b>Steel failure</b>									
Characteristic resistance	$N_{Rk,s}$ [kN]	16	27	40	60	86	126	196	
Partial factor	$\gamma_{Ms}$ [-]	1,53		1,5		1,6	1,5		
<b>Pull-out</b>									
<b>Standard anchorage depth</b>									
Characteristic resistance in uncracked concrete C20/25	$N_{Rk,p}$ [kN]	12	16	25	35	51	62,9	71,3	
<b>Reduced anchorage depth</b>									
Characteristic resistance in uncracked concrete C20/25	$N_{Rk,p}$ [kN]	7,5	9	18	26,7	- <sup>1)</sup>	- <sup>1)</sup>	- <sup>1)</sup>	
<b>Splitting</b>									
<b>Standard anchorage depth</b>									
<u>Splitting for standard thickness of concrete member</u> (The higher resistance of case 1 and case 2 may be applied; $C_{cr,sp}$ may be linearly interpolated for the member thickness $h_{min,2} < h < h_{min,1}$ (Case 2); $\psi_{h,sp} = 1,0$ )									
Standard thickness of concrete	$h_{min,1} \geq$ [mm]	100	120	140	170	200	230	250	
<b>Case 1</b>									
Characteristic resistance in uncracked concrete C20/25	$N^0_{Rk,sp}$ [kN]	9	12	20	30	40	62,3	50	
Edge distance	$C_{cr,sp}$ [mm]	1,5 $h_{ef}$							
<b>Case 2</b>									
Characteristic resistance in uncracked concrete C20/25	$N^0_{Rk,sp}$ [kN]	12	16	25	35	50,5	62,3	70,6	
Edge distance	$C_{cr,sp}$ [mm]	2 $h_{ef}$				2,2 $h_{ef}$	1,5 $h_{ef}$	2,5 $h_{ef}$	
<u>Splitting for minimum thickness of concrete member</u>									
Minimum thickness of concrete	$h_{min,2} \geq$ [mm]	80	100	120	140	- <sup>1)</sup>	- <sup>1)</sup>	- <sup>1)</sup>	
Characteristic resistance in uncracked concrete C20/25	$N^0_{Rk,sp}$ [kN]	12	16	25	35				
Edge distance	$C_{cr,sp}$ [mm]	2,5 $h_{ef}$							
<b>Reduced anchorage depth</b>									
Minimum thickness of concrete	$h_{min,3} \geq$ [mm]	80	80	100	140	- <sup>1)</sup>	- <sup>1)</sup>	- <sup>1)</sup>	
Characteristic resistance in uncracked concrete C20/25	$N^0_{Rk,sp}$ [kN]	7,5	9	17,9	26,5				
Edge distance	$C_{cr,sp}$ [mm]	100	100	125	150				
Increasing factor	$\psi_c$ [-]	$\left(\frac{f_{ck}}{20}\right)^{0,5}$							
<b>Concrete cone failure</b>									
Effective anchorage depth	$h_{ef}$ [mm]	46	60	70	85	100	115	125	
Reduced anchorage depth	$h_{ef,red}$ [mm]	35 <sup>2)</sup>	40	50	65	- <sup>1)</sup>	- <sup>1)</sup>	- <sup>1)</sup>	
Factor for uncracked concrete	$k_{ucr,N}$ [-]	11,0							

<sup>1)</sup> No performance assessed.

<sup>2)</sup> Restricted to the use of structural components with  $h_{ef} < 40$ mm which are statically indeterminate and subject to dry internal exposure conditions only

**DX FAST ETA 1 and DX-I FAST ETA 1**

**Performance**  
Characteristic values for **tension loads, DX FAST ETA 1 (zinc plated), uncracked concrete**, static and quasi-static action

**Annex C3**

**Table C4: Characteristic values for tension loads, DX FAST ETA 1 (A4 / HCR), uncracked concrete, static and quasi-static action**

Fastener size			M8	M10	M12	M16	M20	M24
Installation factor	$\gamma_{inst}$	[-]	1,0					
<b>Steel failure</b>								
Characteristic resistance	$N_{Rk,s}$	[kN]	16	27	40	64	108	110
Partial factor	$\gamma_{Ms}$	[-]	1,5				1,68	1,5
<b>Pull-out</b>								
<b>Standard anchorage depth</b>								
Characteristic resistance in uncracked concrete C20/25	$N_{Rk,p}$	[kN]	12	16	25	35	51	71,3
<b>Reduced anchorage depth</b>								
Characteristic resistance in uncracked concrete C20/25	$N_{Rk,p}$	[kN]	7,5	9	18	26,7	- <sup>1)</sup>	- <sup>1)</sup>
<b>Splitting</b>								
<b>Standard anchorage depth</b>								
<u>Splitting for standard thickness of concrete member</u> (The higher resistance of case 1 and case 2 may be applied; $C_{cr,sp}$ may be linearly interpolated for the member thickness $h_{min,2} < h < h_{min,1}$ (Case 2); $\psi_{h,sp} = 1,0$ )								
Standard thickness of concrete	$h_{min,1} \geq$	[mm]	100	120	140	160	200	250
<b>Case 1</b>								
Characteristic resistance in uncracked concrete C20/25	$N^0_{Rk,sp}$	[kN]	9	12	20	30	40	- <sup>1)</sup>
Edge distance	$C_{cr,sp}$	[mm]	1,5 $h_{ef}$					- <sup>1)</sup>
<b>Case 2</b>								
Characteristic resistance in uncracked concrete C20/25	$N^0_{Rk,sp}$	[kN]	12	16	25	35	50,5	70,6
Edge distance	$C_{cr,sp}$	[mm]	115	125	140	200	220	250
<u>Splitting for minimum thickness of concrete member</u>								
Minimum thickness of concrete	$h_{min,2} \geq$	[mm]	80	100	120	140	- <sup>1)</sup>	- <sup>1)</sup>
Characteristic resistance in uncracked concrete C20/25	$N^0_{Rk,sp}$	[kN]	12	16	25	35		
Edge distance	$C_{cr,sp}$	[mm]	2,5 $h_{ef}$					
<b>Reduced anchorage depth</b>								
Minimum thickness of concrete	$h_{min,3} \geq$	[mm]	80	80	100	140	- <sup>1)</sup>	- <sup>1)</sup>
Characteristic resistance in uncracked concrete C20/25	$N^0_{Rk,sp}$	[kN]	7,5	9	17,9	26,5		
Edge distance	$C_{cr,sp}$	[mm]	100	100	125	150		
Increasing factor	$\psi_c$	[-]	$\left(\frac{f_{ck}}{20}\right)^{0,5}$					
<b>Concrete cone failure</b>								
Effective anchorage depth	$h_{ef}$	[mm]	46	60	70	85	100	125
Reduced anchorage depth	$h_{ef,red}$	[mm]	35 <sup>2)</sup>	40	50	65	- <sup>1)</sup>	- <sup>1)</sup>
Factor for uncracked concrete	$k_{ucr,N}$	[-]	11,0					

<sup>1)</sup> No performance assessed.

<sup>2)</sup> Restricted to the use of structural components with  $h_{ef} < 40$ mm which are statically indeterminate and subject to dry internal exposure conditions only

**DX FAST ETA 1 and DX-I FAST ETA 1**

**Performance**

Characteristic values for tension loads, DX FAST ETA 1 (A4 / HCR), uncracked concrete, static and quasi-static action

**Annex C4**

**Table C5: Characteristic values for shear loads, DX FAST ETA 1, cracked and uncracked concrete, static or quasi static action**

Fastener size			M8	M10	M12	M16	M20	M24	M27	
Installation factor	$\gamma_{inst}$	[-]	1,0							
<b>Steel failure without lever arm, Steel zinc plated</b>										
Characteristic resistance	$V_{RK,s}^0$	[kN]	12,2	20,1	30	55	69	114	169,4	
Ductility factor	$k_7$	[-]	1,0							
Partial factor	$\gamma_{Ms}$	[-]	1,25				1,33	1,25	1,25	
<b>Steel failure without lever arm, Stainless steel A4, HCR</b>										
Characteristic resistance	$V_{RK,s}^0$	[kN]	13	20	30	55	86	123,6	- <sup>1)</sup>	
Ductility factor	$k_7$	[-]	1,0							
Partial factor	$\gamma_{Ms}$	[-]	1,25				1,4	1,25		
<b>Steel failure with lever arm, Steel zinc plated</b>										
Characteristic bending resistance	$M_{RK,s}^0$	[Nm]	23	47	82	216	363	898	1331,5	
Partial factor	$\gamma_{Ms}$	[-]	1,25				1,33	1,25	1,25	
<b>Steel failure with lever arm, Stainless steel A4, HCR</b>										
Characteristic bending resistance	$M_{RK,s}^0$	[Nm]	26	52	92	200	454	785,4	- <sup>1)</sup>	
Partial factor	$\gamma_{Ms}$	[-]	1,25				1,4	1,25		
<b>Concrete pry-out failure</b>										
Pry-out factor	$k_8$	[-]	2,4				2,8			
<b>Concrete edge failure</b>										
Effective length of fastener in shear loading with $h_{ef}$	Steel zinc plated	$l_f$	[mm]	46	60	70	85	100	115	125
	Stainless steel A4, HCR	$l_f$	[mm]	46	60	70	85	100	125	- <sup>1)</sup>
Effective length of fastener in shear loading with $h_{ef,red}$	Steel zinc plated	$l_{f,red}$	[mm]	35 <sup>2)</sup>	40	50	65	- <sup>1)</sup>	- <sup>1)</sup>	- <sup>1)</sup>
	Stainless steel A4, HCR	$l_{f,red}$	[mm]	35 <sup>2)</sup>	40	50	65			
Outside diameter of fastener	$d_{nom}$	[mm]	8	10	12	16	20	24	27	

<sup>1)</sup> No performance assessed.

<sup>2)</sup> Restricted to the use of structural components with  $h_{ef} < 40$ mm which are statically indeterminate and subject to dry internal exposure conditions only

**DX FAST ETA 1 and DX-I FAST ETA 1**

**Performance**  
Characteristic values for **shear loads, DX FAST ETA 1, cracked and uncracked concrete, static or quasi static action**

**Annex C5**

**Table C6: Characteristic resistance for seismic loading, DX FAST ETA 1, standard anchorage depth, performance category C1 and C2**

Fastener size		M8	M10	M12	M16	M20	
<b>Tension loads</b>							
Installation factor	$\gamma_{inst}$	[-]	1,0				
<b>Steel failure, Steel zinc plated</b>							
Characteristic resistance C1	$N_{Rk,s,eq,C1}$	[kN]	16	27	40	60	86
Characteristic resistance C2	$N_{Rk,s,eq,C2}$	[kN]	16	27	40	60	86
Partial factor	$\gamma_{Ms}$	[-]	1,53		1,5		1,6
<b>Steel failure, Stainless steel A4, HCR</b>							
Characteristic resistance C1	$N_{Rk,s,eq,C1}$	[kN]	16	27	40	64	108
Characteristic resistance C2	$N_{Rk,s,eq,C2}$	[kN]	16	27	40	64	108
Partial factor	$\gamma_{Ms}$	[-]	1,5				1,68
<b>Pull-out (steel zinc plated, stainless steel A4 and HCR)</b>							
Characteristic resistance C1	$N_{Rk,p,eq,C1}$	[kN]	5	9	16	25	36
Characteristic resistance C2	$N_{Rk,p,eq,C2}$	[kN]	2,3	3,6	10,2	13,8	24,4
<b>Shear loads</b>							
<b>Steel failure without lever arm, Steel zinc plated</b>							
Characteristic resistance C1	$V_{Rk,s,eq,C1}$	[kN]	9,3	20	27	44	69
Characteristic resistance C2	$V_{Rk,s,eq,C2}$	[kN]	6,7	14	16,2	35,7	55,2
Partial factor	$\gamma_{Ms}$	[-]	1,25				1,33
<b>Steel failure without lever arm, Stainless steel A4, HCR</b>							
Characteristic resistance C1	$V_{Rk,s,eq,C1}$	[kN]	9,3	20	27	44	69
Characteristic resistance C2	$V_{Rk,s,eq,C2}$	[kN]	6,7	14	16,2	35,7	55,2
Partial factor	$\gamma_{Ms}$	[-]	1,25				1,4
Factor for annular gap	<b>without</b> filling of annular gap	$\alpha_{gap}$	[-]	0,5			
	<b>with</b> filling of annular gap	$\alpha_{gap}$	[-]	1,0			

DX FAST ETA 1 and DX-I FAST ETA 1

**Performance**  
Characteristic resistance for **seismic loading, DX FAST ETA 1, standard anchorage depth, performance category C1 and C2**

**Annex C6**

**Table C7: Characteristic values for tension and shear load under fire exposure, DX FAST ETA 1, standard anchorage depth, cracked and uncracked concrete C20/25 to C50/60**

Fastener size		M8	M10	M12	M16	M20	M24	M27		
<b>Tension load</b>										
<b>Steel failure</b>										
<b>Steel, zinc plated</b>										
Characteristic resistance	R30	$N_{Rk,s,fi}$	[kN]	1,5	2,6	4,1	7,7	9,4	13,6	17,6
	R60			1,1	1,9	3,0	5,6	8,2	11,8	15,3
	R90			0,8	1,4	2,4	4,4	6,9	10,0	13,0
	R120			0,7	1,2	2,2	4,0	6,3	9,1	11,8
<b>Stainless steel A4, HCR</b>										
Characteristic resistance	R30	$N_{Rk,s,fi}$	[kN]	3,8	6,9	12,7	23,7	33,5	48,2	_1)
	R60			2,9	5,3	9,4	17,6	25,0	35,9	
	R90			2,0	3,6	6,1	11,5	16,4	23,6	
	R120			1,6	2,8	4,5	8,4	12,1	17,4	
<b>Shear load</b>										
<b>Steel failure without lever arm</b>										
<b>Steel, zinc plated</b>										
Characteristic resistance	R30	$V_{Rk,s,fi}$	[kN]	1,6	2,6	4,1	7,7	11	16	20,6
	R60			1,5	2,5	3,6	6,8	11	15	19,8
	R90			1,2	2,1	3,5	6,5	10	15	19,0
	R120			1,0	2,0	3,4	6,4	10	14	18,6
<b>Stainless steel A4, HCR</b>										
Characteristic resistance	R30	$V_{Rk,s,fi}$	[kN]	3,8	6,9	12,7	23,7	33,5	48,2	_1)
	R60			2,9	5,3	9,4	17,6	25,0	35,9	
	R90			2,0	3,6	6,1	11,5	16,4	23,6	
	R120			1,6	2,8	4,5	8,4	12,1	17,4	
<b>Steel failure with lever arm</b>										
<b>Steel, zinc plated</b>										
Characteristic resistance	R30	$M^0_{Rk,s,fi}$	[Nm]	1,7	3,3	6,4	16,3	29	50	75
	R60			1,6	3,2	5,6	14	28	48	72
	R90			1,2	2,7	5,4	14	27	47	69
	R120			1,1	2,5	5,3	13	26	46	68
<b>Stainless steel A4, HCR</b>										
Characteristic resistance	R30	$M^0_{Rk,s,fi}$	[Nm]	3,8	9,0	19,7	50,1	88,8	153,5	_1)
	R60			2,9	6,8	14,6	37,2	66,1	114,3	
	R90			2,1	4,7	9,5	24,2	43,4	75,1	
	R120			1,6	3,6	7,0	17,8	32,1	55,5	

<sup>1)</sup> No performance assessed

**DX FAST ETA 1 and DX-I FAST ETA 1**

**Performance**

Characteristic values for tension and shear load under fire exposure, DX FAST ETA 1, standard anchorage depth, cracked and uncracked concrete C20/25 to C50/60

**Annex C7**

**Table C8: Characteristic values for tension and shear load under fire exposure, DX FAST ETA 1, reduced anchorage depth, cracked and uncracked concrete C20/25 to C50/60**

Fastener size		M8	M10	M12	M16		
<b>Tension load</b>							
<b>Steel failure</b>							
<b>Steel, zinc plated</b>							
Characteristic resistance	R30	$N_{Rk,s,fi}$	[kN]	1,5	2,6	4,1	7,7
	R60			1,1	1,9	3,0	5,6
	R90			0,8	1,3	1,9	3,5
	R120			0,6	1,0	1,3	2,5
<b>Stainless steel A4, HCR</b>							
Characteristic resistance	R30	$N_{Rk,s,fi}$	[kN]	3,2	6,9	12,7	23,7
	R60			2,5	5,3	9,4	17,6
	R90			1,9	3,6	6,1	11,5
	R120			1,6	2,8	4,5	8,4
<b>Shear load</b>							
<b>Steel failure without lever arm</b>							
<b>Steel, zinc plated</b>							
Characteristic resistance	R30	$V_{Rk,s,fi}$	[kN]	1,5	2,6	4,1	7,7
	R60			1,1	1,9	3,0	5,6
	R90			0,8	1,3	1,9	3,5
	R120			0,6	1,0	1,3	2,5
<b>Stainless steel A4, HCR</b>							
Characteristic resistance	R30	$V_{Rk,s,fi}$	[kN]	3,2	6,9	12,7	23,7
	R60			2,5	5,3	9,4	17,6
	R90			1,9	3,6	6,1	11,5
	R120			1,6	2,8	4,5	8,4
<b>Steel failure with lever arm</b>							
<b>Steel, zinc plated</b>							
Characteristic resistance	R30	$M^0_{Rk,s,fi}$	[Nm]	1,5	3,3	6,4	16,3
	R60			1,2	2,5	4,7	11,9
	R90			0,8	1,7	3,0	7,5
	R120			0,6	1,2	2,1	5,3
<b>Stainless steel A4, HCR</b>							
Characteristic resistance	R30	$M^0_{Rk,s,fi}$	[Nm]	3,2	8,9	19,7	50,1
	R60			2,6	6,8	14,6	37,2
	R90			2,0	4,7	9,5	24,2
	R120			1,6	3,6	7,0	17,8

**DX FAST ETA 1 and DX-I FAST ETA 1**

**Performance**  
Characteristic values for tension and shear load under fire exposure, DX FAST ETA 1, reduced anchorage depth, cracked and uncracked concrete C20/25 to C50/60

**Annex C8**

**Table C9: Displacements under tension load, DX FAST ETA 1**

Fastener size			M8	M10	M12	M16	M20	M24	M27
<b>Standard anchorage depth</b>									
<b>Steel zinc plated</b>									
Tension load in cracked concrete	N	[kN]	2,4	4,3	7,6	11,9	17,1	21,1	24
Displacement	$\delta_{N0}$	[mm]	0,6	1,0	0,4	1,0	0,9	0,7	0,9
	$\delta_{N\infty}$	[mm]	1,4	1,2	1,4	1,3	1,0	1,2	1,4
Tension load in uncracked concrete	N	[kN]	5,7	7,6	11,9	16,7	23,8	29,6	34
Displacement	$\delta_{N0}$	[mm]	0,4	0,5	0,7	0,3	0,4	0,5	0,3
	$\delta_{N\infty}$	[mm]	0,8		1,4	0,8		1,4	
<b>Displacements under seismic tension loads C2</b>									
Displacements	$\delta_{N,eq(0,5)}$	[mm]	2,3	4,1	4,9	3,6	5,1	- <sup>1)</sup>	- <sup>1)</sup>
Displacements	$\delta_{N,eq(0,8)}$	[mm]	8,2	13,8	15,7	9,5	15,2	- <sup>1)</sup>	- <sup>1)</sup>
<b>Stainless steel A4, HCR</b>									
Tension load in cracked concrete	N	[kN]	2,4	4,3	7,6	11,9	17,1	19,0	- <sup>1)</sup>
Displacement	$\delta_{N0}$	[mm]	0,7	1,8	0,4	0,7	0,9	0,5	
	$\delta_{N\infty}$	[mm]	1,2	1,4	1,4	1,4	1,0	1,8	
Tension load in uncracked concrete	N	[kN]	5,8	7,6	11,9	16,7	23,8	33,5	- <sup>1)</sup>
Displacement	$\delta_{N0}$	[mm]	0,6	0,5	0,7	0,2	0,4	0,5	
	$\delta_{N\infty}$	[mm]	1,2	1,0	1,4	0,4	0,8	1,1	
<b>Displacements under seismic tension loads C2</b>									
Displacements	$\delta_{N,eq(0,5)}$	[mm]	2,3	4,1	4,9	3,6	5,1	- <sup>1)</sup>	- <sup>1)</sup>
Displacements	$\delta_{N,eq(0,8)}$	[mm]	8,2	13,8	15,7	9,5	15,2	- <sup>1)</sup>	- <sup>1)</sup>
<b>Reduced anchorage depth</b>									
<b>Steel zinc plated, stainless steel A4, HCR</b>									
Tension load in cracked concrete	N	[kN]	2,4	3,6	6,1	9,0	- <sup>1)</sup>	- <sup>1)</sup>	- <sup>1)</sup>
Displacement	$\delta_{N0}$	[mm]	0,8	0,7	0,5	1,0			
	$\delta_{N\infty}$	[mm]	1,2	1,0	0,8	1,1			
Tension load in uncracked concrete	N	[kN]	3,7	4,3	8,5	12,6	- <sup>1)</sup>	- <sup>1)</sup>	- <sup>1)</sup>
Displacement	$\delta_{N0}$	[mm]	0,1	0,2	0,2	0,2			
	$\delta_{N\infty}$	[mm]	0,7	0,7	0,7	0,7			

<sup>1)</sup> No performance assessed

**DX FAST ETA 1 and DX-I FAST ETA 1**

**Performance**  
Displacements under tension load, DX FAST ETA 1

**Annex C9**

**Table C10: Displacements under shear load, DX FAST ETA 1**

Fastener size			M8	M10	M12	M16	M20	M24	M27
<b>Standard anchorage depth</b>									
<b>Steel zinc plated</b>									
Shear load in cracked and uncracked concrete	V	[kN]	6,9	11,4	17,1	31,4	36,8	64,9	96,8
Displacement	$\delta_{V0}$	[mm]	2,0	3,2	3,6	3,5	1,8	3,5	3,6
	$\delta_{V\infty}$	[mm]	3,0	4,7	5,5	5,3	2,7	5,3	5,4
<b>Displacements under seismic shear loads C2</b>									
Displacements	$\delta_{V,eq(0,5)}$	[mm]	3,0	2,7	3,5	4,3	4,7	- <sup>1)</sup>	- <sup>1)</sup>
Displacements	$\delta_{V,eq(0,8)}$	[mm]	5,9	5,3	9,5	9,6	10,1		
<b>Stainless steel A4, HCR</b>									
Shear load in cracked and uncracked concrete	V	[kN]	7,3	11,4	17,1	31,4	43,8	70,6	- <sup>1)</sup>
Displacement	$\delta_{V0}$	[mm]	1,9	2,4	4,0	4,3	2,9	2,8	
	$\delta_{V\infty}$	[mm]	2,9	3,6	5,9	6,4	4,3	4,2	
<b>Displacements under seismic shear loads C2</b>									
Displacements	$\delta_{V,eq(0,5)}$	[mm]	3,0	2,7	3,5	4,3	4,7	- <sup>1)</sup>	- <sup>1)</sup>
Displacements	$\delta_{V,eq(0,8)}$	[mm]	5,9	5,3	9,5	9,6	10,1		
<b>Reduced anchorage depth</b>									
<b>Steel zinc plated</b>									
Shear load in cracked and uncracked concrete	V	[kN]	6,9	11,4	17,1	31,4	- <sup>1)</sup>	- <sup>1)</sup>	- <sup>1)</sup>
Displacement	$\delta_{V0}$	[mm]	2,0	3,2	3,6	3,5			
	$\delta_{V\infty}$	[mm]	3,0	4,7	5,5	5,3			
<b>Stainless steel A4, HCR</b>									
Shear load in cracked and uncracked concrete	V	[kN]	7,3	11,4	17,1	31,4	- <sup>1)</sup>	- <sup>1)</sup>	- <sup>1)</sup>
Displacement	$\delta_{V0}$	[mm]	1,9	2,4	4,0	4,3			
	$\delta_{V\infty}$	[mm]	2,9	3,6	5,9	6,4			

<sup>1)</sup> No performance assessed

**DX FAST ETA 1 and DX-I FAST ETA 1**

**Performance**  
Displacements under shear load, DX FAST ETA 1

**Annex C10**

**Table C11: Characteristic values for tension loads, DX-I FAST ETA 1, cracked concrete, static and quasi-static action**

Fastener size			M6	M8	M10	M12
Installation factor	$\gamma_{inst}$	[-]	1,2			
<b>Steel failure</b>						
Characteristic resistance, steel zinc plated	$N_{Rk,s}$	[kN]	16,1	22,6	26,0	56,6
Partial factor	$\gamma_{Ms}$	[-]	1,5			
Characteristic resistance, stainless steel A4, HCR	$N_{Rk,s}$	[kN]	14,1	25,6	35,8	59,0
	$\gamma_{Ms}$	[-]	1,87			
<b>Pull-out failure</b>						
Characteristic resistance in cracked concrete C20/25	$N_{Rk,p}$	[kN]	5	9	12	20
Increasing factor for $N_{Rk,p} = \psi_c \cdot N_{Rk,p} (C20/25)$	$\psi_c$	[-]	$\left(\frac{f_{ck}}{20}\right)^{0,5}$			
<b>Concrete cone failure</b>						
Effective anchorage depth	$h_{ef}$	[mm]	45	58	65	80
Factor for cracked concrete	$k_{cr,N}$	[-]	7,7			

DX FAST ETA 1 and DX-I FAST ETA 1

**Performance**  
Characteristic values for tension loads, DX-I FAST ETA 1, cracked concrete, static and quasi-static action

**Annex C11**

**Table C12: Characteristic values for tension loads, DX-I FAST ETA 1, uncracked concrete, static and quasi-static action**

Fastener size			M6	M8	M10	M12
Installation factor	$\gamma_{inst}$	[-]	1,2			
<b>Steel failure</b>						
Characteristic resistance, steel zinc plated	$N_{RK,s}$	[kN]	16,1	22,6	26,0	56,6
Partial factor	$\gamma_{Ms}$	[-]	1,5			
Characteristic resistance, stainless steel A4, HCR	$N_{RK,s}$	[kN]	14,1	25,6	35,8	59,0
Partial factor	$\gamma_{Ms}$	[-]	1,87			
<b>Pull-out</b>						
Characteristic resistance in uncracked concrete C20/25	$N_{RK,p}$	[kN]	12	16	20	30
<b>Splitting</b> (the higher resistance of Case 1 and Case 2 may be applied)						
Minimum thickness of concrete member	$h_{min}$	[mm]	100	120	130	160
<b>Case 1</b>						
Characteristic resistance in uncracked concrete C20/25	$N^0_{RK,sp}$	[kN]	9	12	16	25
Edge distance	$c_{cr,sp}$	[mm]	1,5 $h_{ef}$			
<b>Case 2</b>						
Characteristic resistance in uncracked concrete C20/25	$N^0_{RK,sp}$	[kN]	12	16	20	30
Edge distance	$c_{cr,sp}$	[mm]	2,5 $h_{ef}$			
Increasing factor for $N_{RK,p} = \psi_c \cdot N_{RK,p} (C20/25)$ $N^0_{RK,sp} = \psi_c \cdot N^0_{RK,sp} (C20/25)$	$\psi_c$	[-]	$\left(\frac{f_{ck}}{20}\right)^{0,5}$			
<b>Concrete cone failure</b>						
Effective anchorage depth	$h_{ef}$	[mm]	45	58	65	80
Factor for uncracked concrete	$k_{ucr,N}$	[-]	11,0			

DX FAST ETA 1 and DX-I FAST ETA 1

**Performance**  
Characteristic values for **tension loads, DX-I FAST ETA 1, uncracked concrete**, static and quasi-static action

**Annex C12**

**Table C13: Characteristic values for shear loads, DX-I FAST ETA 1, cracked and uncracked concrete, static and quasi-static action**

Fastener size		M6	M8	M10	M12
Installation factor	$\gamma_{inst}$ [-]	1,0			
<b>DX-I FAST ETA 1, steel zinc plated</b>					
<b>Steel failure without lever arm, pre-setting installation</b>					
Characteristic resistance	$V_{RK,s}^0$ [kN]	5,8	6,9	10,4	25,8
<b>Steel failure without lever arm, through-setting installation</b>					
Characteristic resistance	$V_{RK,s}^0$ [kN]	5,1	7,6	10,8	24,3
<b>Steel failure with lever arm, pre-setting installation</b>					
Characteristic bending resistance	$M_{RK,s}^0$ [Nm]	12,2	30,0	59,8	104,6
<b>Steel failure with lever arm, through-setting installation</b>					
Characteristic bending resistance	$M_{RK,s}^0$ [Nm]	36,0	53,2	76,0	207
Partial factor for $V_{RK,s}$ and $M_{RK,s}^0$	$\gamma_{Ms}$ [-]	1,25			
Ductility factor	$k_7$ [-]	1,0			
<b>DX-I FAST ETA 1, stainless steel A4, HCR</b>					
<b>Steel failure without lever arm, pre-setting installation</b>					
Characteristic resistance	$V_{RK,s}^0$ [kN]	5,7	9,2	10,6	23,6
Partial factor	$\gamma_{Ms}$ [-]	1,25			
<b>Steel failure without lever arm, through-setting installation</b>					
Characteristic resistance	$V_{RK,s}^0$ [kN]	7,3	7,6	9,7	29,6
Partial factor	$\gamma_{Ms}$ [-]	1,25			
<b>Steel failure with lever arm, pre-setting installation</b>					
Characteristic bending resistance	$M_{RK,s}^0$ [Nm]	10,7	26,2	52,3	91,6
Partial factor	$\gamma_{Ms}$ [-]	1,56			
<b>Steel failure with lever arm, through-setting installation</b>					
Characteristic bending resistance	$M_{RK,s}^0$ [Nm]	28,2	44,3	69,9	191,2
Partial factor	$\gamma_{Ms}$ [-]	1,25			
Ductility factor	$k_7$ [-]	1,0			
<b>Concrete pry-out failure</b>					
Pry-out factor	$k_8$ [-]	1,5	1,5	2,0	2,0
<b>Concrete edge failure</b>					
Effective length of fastener in shear loading	$l_f$ [mm]	45	58	65	80
Effective diameter of fastener	$d_{nom}$ [mm]	8	10	12	16

**DX FAST ETA 1 and DX-I FAST ETA 1**

**Performance**  
Characteristic values for **shear loads, DX-I FAST ETA 1, cracked and uncracked concrete, static and quasi-static action**

**Annex C13**

**Table C14: Characteristic values for tension and shear load under fire exposure, DX-I FAST ETA 1, cracked and uncracked concrete C20/25 to C50/60**

Fastener size		M6	M8	M10	M12	
<b>Tension load</b>						
<b>Steel failure</b>						
<b>Steel zinc plated</b>						
Characteristic resistance	R30	$N_{Rk,s,fi}$ [kN]	0,7	1,4	2,5	3,7
	R60		0,6	1,2	2,0	2,9
	R90		0,5	0,9	1,5	2,2
	R120		0,4	0,8	1,3	1,8
<b>Stainless steel A4, HCR</b>						
Characteristic resistance	R30	$N_{Rk,s,fi}$ [kN]	2,9	5,4	8,7	12,6
	R60		1,9	3,8	6,3	9,2
	R90		1,0	2,1	3,9	5,7
	R120		0,5	1,3	2,7	4,0
<b>Shear load</b>						
<b>Steel failure without lever arm</b>						
<b>Steel zinc plated</b>						
Characteristic resistance	R30	$V_{Rk,s,fi}$ [kN]	0,7	1,4	2,5	3,7
	R60		0,6	1,2	2,0	2,9
	R90		0,5	0,9	1,5	2,2
	R120		0,4	0,8	1,3	1,8
<b>Stainless steel A4, HCR</b>						
Characteristic resistance	R30	$V_{Rk,s,fi}$ [kN]	2,9	5,4	8,7	12,6
	R60		1,9	3,8	6,3	9,2
	R90		1,0	2,1	3,9	5,7
	R120		0,5	1,3	2,7	4,0
<b>Steel failure with lever arm</b>						
<b>Steel zinc plated</b>						
Characteristic resistance	R30	$M^0_{Rk,s,fi}$ [Nm]	0,5	1,4	3,3	5,7
	R60		0,4	1,2	2,6	4,6
	R90		0,4	0,9	2,0	3,4
	R120		0,3	0,8	1,6	2,8
<b>Stainless steel A4, HCR</b>						
Characteristic resistance	R30	$M^0_{Rk,s,fi}$ [Nm]	2,2	5,5	11,2	19,6
	R60		1,5	3,9	8,1	14,3
	R90		0,7	2,2	5,1	8,9
	R120		0,4	1,3	3,5	6,2

DX FAST ETA 1 and DX-I FAST ETA 1

**Performance**  
Characteristic values for **tension** and **shear loads** under **fire exposure**,  
**DX-I FAST ETA 1**, cracked and uncracked concrete C20/25 to C50/60

**Annex C14**

**Table C15: Displacements under tension load, DX-I FAST ETA 1**

Fastener size			M6	M8	M10	M12
Tension load in cracked concrete	N	[kN]	2,0	3,6	4,8	8,0
Displacements	$\delta_{N0}$	[mm]	0,6	0,6	0,8	1,0
	$\delta_{N\infty}$	[mm]	0,8	0,8	1,2	1,4
Tension load in uncracked concrete	N	[kN]	4,8	6,4	8,0	12,0
Displacements	$\delta_{N0}$	[mm]	0,4	0,5	0,7	0,8
	$\delta_{N\infty}$	[mm]	0,8	0,8	1,2	1,4

**Table C16: Displacements under shear load, DX-I FAST ETA 1**

Fastener size			M6	M8	M10	M12
Shear load in cracked and uncracked concrete	V	[kN]	4,2	5,3	6,2	16,9
Displacements	$\delta_{V0}$	[mm]	2,8	2,9	2,5	3,6
	$\delta_{V\infty}$	[mm]	4,2	4,4	3,8	5,3

**DX FAST ETA 1 and DX-I FAST ETA 1**

**Performance**  
Displacements under tension load and under shear load, **DX-I FAST ETA 1**

**Annex C15**