

Public-law institution jointly founded by the
federal states and the Federation

European Technical Assessment Body
for construction products



European Technical Assessment

ETA-15/0271
of 9 February 2026

English translation prepared by DIBt - Original version in German language

General Part

Technical Assessment Body issuing the
European Technical Assessment:

Deutsches Institut für Bautechnik

Trade name of the construction product

Injection system IM XTREME ETA 1

Product family
to which the construction product belongs

Bonded fasteners and bonded expansion fasteners for
use in concrete

Manufacturer

Ter Laare B.V.
Postbus 355
NL-3140 AJ MAASSLUIS
NIEDERLANDE

Manufacturing plant

Ter Laare Verankeringsstechnieken BV
Herstellwerk 3
Herstellwerk 1

This European Technical Assessment
contains

32 pages including 3 annexes which form an integral part
of this assessment

This European Technical Assessment is
issued in accordance with Article 95(4) of
Regulation (EU) No 2024/3110, on the basis of

EAD 330499-02-0601

This version replaces

ETA-15/0271 issued on 5 June 2015

The European Technical Assessment is issued by the Technical Assessment Body in its official language. Translations of this European Technical Assessment in other languages shall fully correspond to the original issued document and shall be identified as such.

Communication of this European Technical Assessment, including transmission by electronic means, shall be in full. However, partial reproduction may only be made with the written consent of the issuing Technical Assessment Body. Any partial reproduction shall be identified as such.

This European Technical Assessment may be withdrawn by the issuing Technical Assessment Body, in particular pursuant to information by the Commission in accordance with Article 36(3) of Regulation (EU) No 2024/3110.

Specific Part

1 Technical description of the product

The "Injection System IM XRTEME ETA 1" is a torque controlled bonded anchor consisting of a cartridge with injection mortar IM XTREME ETA 1 or IM XTREME ETA express and an anchor rod with expansion cones and external connection thread (type AX XTREME ETA 1) or with internal connection thread (type AX-I XTREME ETA 1).

The load transfer is realised by mechanical interlock of several cones in the bonding mortar and then via a combination of bonding and friction forces in the anchorage ground (concrete).

The product description is given in Annex A.

2 Specification of the intended use in accordance with the applicable European Assessment Document

The performances given in Section 3 are only valid if the anchor is used in compliance with the specifications and conditions given in Annex B.

The verifications and assessment methods on which this European Technical Assessment is based lead to the assumption of a working life of the anchor of at least 50 years. The indications given on the working life cannot be interpreted as a guarantee given by the producer, but are to be regarded only as a means for choosing the right products in relation to the expected economically reasonable working life of the works.

3 Performance of the product and references to the methods used for its assessment

3.1 Mechanical resistance and stability (BWR 1)

| Essential characteristic | Performance |
|--|---------------------------------|
| Characteristic resistance to tension load (static and quasi-static loading) | See Annex C1 – C3, C10, B4 – B6 |
| Characteristic resistance to shear load (static and quasi-static loading) | See Annex C4 – C5, C11 |
| Displacements under short-term and long-term loading | See Annex C8 – C9, C11 |
| Characteristic resistance and displacements for seismic performance categories C1 and C2 | See Annex C6 – C9 |

3.2 Safety in case of fire (BWR 2)

| Essential characteristic | Performance |
|--------------------------|-------------------------|
| Reaction to fire | Class A1 |
| Resistance to fire | No performance assessed |

3.3 Hygiene, health and the environment (BWR 3)

| Essential characteristic | Performance |
|--|-------------------------|
| Content, emission and/or release of dangerous substances | No performance assessed |

4 Assessment and verification of constancy of performance (AVCP) system applied, with reference to its legal base

In accordance with EAD 330499-02-0601 the applicable European legal act is: [96/582/EC]

The system to be applied is: 1

5 Technical details necessary for the implementation of the AVCP system, as provided for in the applicable European Assessment Document

Technical details necessary for the implementation of the AVCP system are laid down in the control plan deposited at Deutsches Institut für Bautechnik.

Issued in Berlin on 9 February 2026 by Deutsches Institut für Bautechnik

Dipl.-Ing. Beatrix Wittstock
Head of Section

beglaubigt:
Baderschneider

Anchor rod AX XTREME ETA 1

Pre-setting installation (and through-setting installation AX XTREME ETA 1 75 M12, see Annex B11)

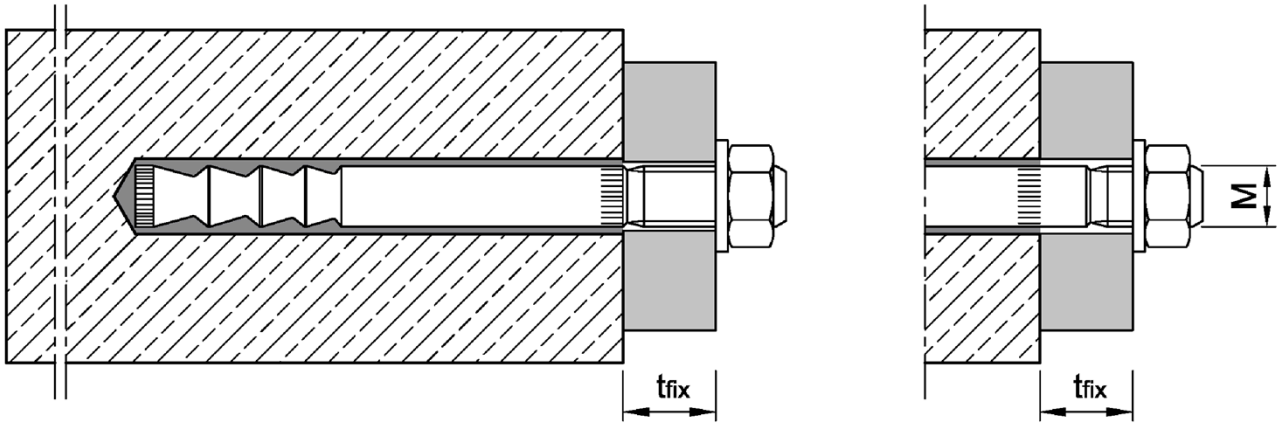

Through-setting installation

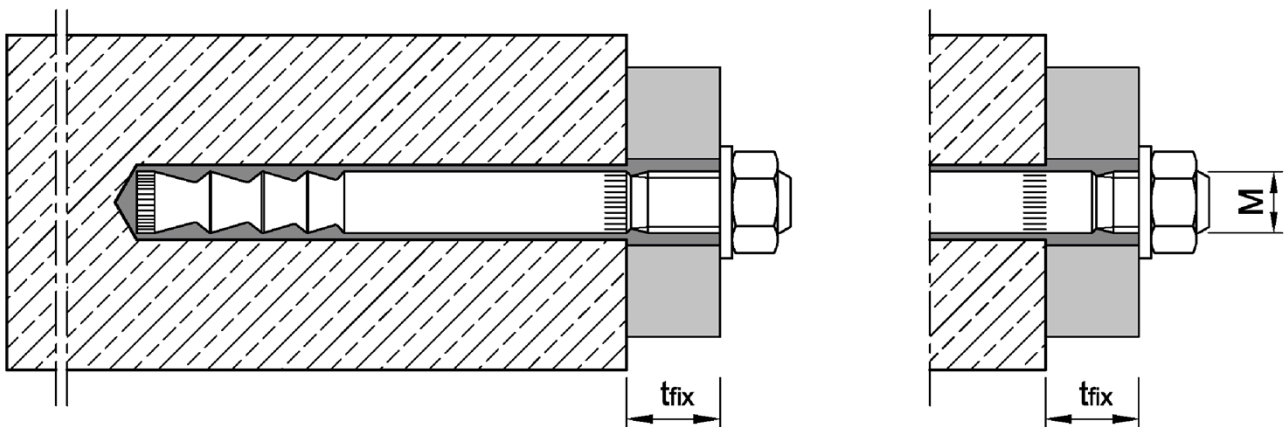

Anchor rod AX-I XTREME ETA 1 with internal thread¹⁾

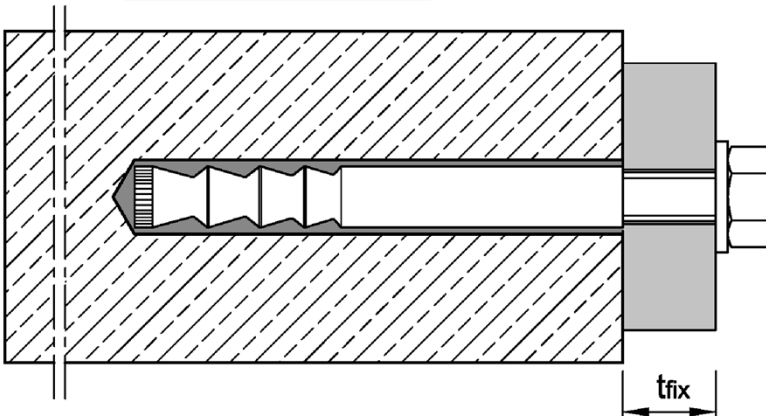

¹⁾ Illustration with hexagon head screw exemplified; other screws or threaded rods also permitted (see Annex A5, requirements of the fastening screw or threaded rod).

Injection System IM XTREME ETA 1

Product description
Installation situation

Annex A1

Injection System IM XTREME ETA 1

Coaxial cartridge

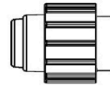

Imprint:
IM XTREME ETA 1 or **IM XTREME ETA express**
processing and safety instructions, shelf life,
charge number, manufacturer's information,
quantity information

Side-by-side cartridge

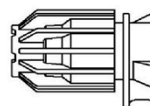

Imprint:
IM XTREME ETA 1 or **IM XTREME ETA express**
processing and safety instructions, shelf life,
charge number, manufacturer's information,
quantity information



Reducing adapter

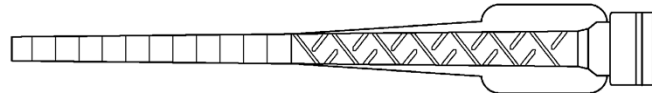

Static mixer VM-X



Blow-out pump VM-AP



Air Blower VM-ABP

Cleaning Brush RB



**Anchor rod
AX XTREME ETA 1**

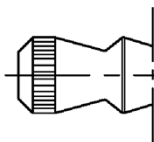

**Washer
(optional: filling washer)**

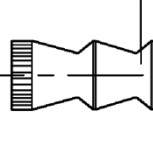

Hexagon nut

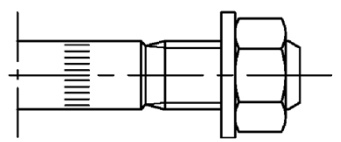

Anchor rod AX-I XTREME ETA 1

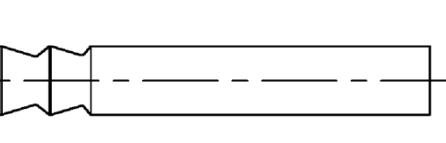
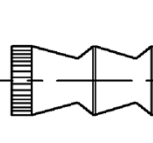
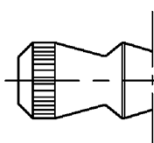

Injection System IM XTREME ETA 1

Product description
Cartridges, Cleaning tools, Anchor types

Annex A2

Table A1: Materials AX XTREME ETA 1

| Part | Designation | Steel, zinc plated | | | Stainless steel A4 (CRC III) | High corrosion resistant steel HCR (CRC V) |
|------|---------------------|---|--|--|--|---|
| | | galvanized ≥ 5 µm | hot-dip galvanized ≥ 50 µm (on average) | sherardized ≥ 45 µm | | |
| 1 | Anchor rod | Steel acc. to EN ISO 683-4:2018 | | | Stainless steel, 1.4401, 1.4404, 1.4571, EN 10088:2023, coated | High corrosion resistant steel 1.4529, 1.4565 EN 10088:2023, coated |
| | | galvanized and coated | hot-dip galvanized and coated | sherardized and coated | | |
| 2a | Washer | Steel, zinc plated | | | Stainless steel, EN 10088:2023 | High corrosion resistant steel 1.4529, 1.4565 EN 10088:2023 |
| 2b | Filling washer | | | | | |
| 3 | Hexagon nut | Property class 8 acc to EN ISO 898-2:2022 | | | EN ISO 3506-2: 2020, A4-70, A4-80 1.4401, 1.4571 EN 10088:2023 | EN ISO 3506-2:2020, Property class 70, high corrosion resistant steel 1.4529, 1.4565 EN 10088:2023 |
| | | galvanized | hot-dip galvanized | sherardized or hot dip- galvanized | | |
| 4 | Mortar cartridge | Vinylester resin, styrene free, mixing ratio 1:10 | | | | |

Marking e.g.: \diamond 80 VMZ 12-25 Marking of anchorage depth

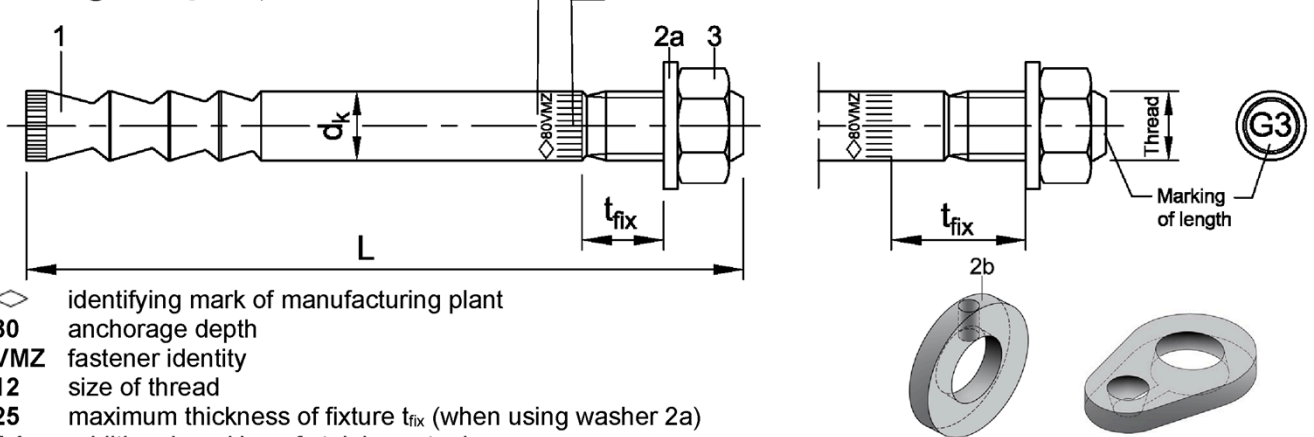

Filling washer VR or alternative filling washer

| Marking of length | | B | C | D | E | F | G | H | I | J | K | L | M | N |
|-------------------|-------|------|------|------|-------|-------|-------|-------|-------|-------|-------|-------|-------|-------|
| Length of anchor | min ≥ | 50,8 | 63,5 | 76,2 | 88,9 | 101,6 | 114,3 | 127,0 | 139,7 | 152,4 | 165,1 | 177,8 | 190,5 | 203,2 |
| | max < | 63,5 | 76,2 | 88,9 | 101,6 | 114,3 | 127,0 | 139,7 | 152,4 | 165,1 | 177,8 | 190,5 | 203,2 | 215,9 |

| Marking of length | | O | P | Q | R | S | T | U | V | W | X | Y | Z | >Z |
|-------------------|-------|-------|-------|-------|-------|-------|-------|-------|-------|-------|-------|-------|-------|-------|
| Length of anchor | min ≥ | 215,9 | 228,6 | 241,3 | 254,0 | 279,4 | 304,8 | 330,2 | 355,6 | 381,0 | 406,4 | 431,8 | 457,2 | 482,6 |
| | max < | 228,6 | 241,3 | 254,0 | 279,4 | 304,8 | 330,2 | 355,6 | 381,0 | 406,4 | 431,8 | 457,2 | 482,6 | |

Injection System IM XTREME ETA 1

Product description
AX XTREME ETA 1: Materials, Marking, Marking of length

Annex A3

Table A2: Dimensions of anchor rod, AX XTREME ETA 1 M8 – M12

| Anchor size | AX XTREME ETA 1 | 40 M8 | 50 M8 | 60 M10 | 75 M10 | 75 M12 | 70 M12 | 80 M12 | 95 M12 | 100 M12 | 110 M12 | 125 M12 | |
|--------------------|-----------------|---|-------------------|-------------------|-------------------|-------------------|-------------------|-------------------|--------------------|--------------------|--------------------|--------------------|--------------------|
| Additional marking | | 1 | 2 | 1 | 2 | 1 | 2 | 3 | 4 | 5 | 6 | 7 | |
| 1 | Anchor rod | Thread | M8 | | M10 | | M12 | | | | | | |
| | | Number of cones | 2 | 3 | 3 | 3 | 3 | 3 | 4 | 4 | 6 | 6 | 6 |
| | | $d_k =$ | 8,0 | 8,0 | 9,7 | 9,7 | 10,7 | 12,5 | 12,5 | 12,5 | 12,5 | 12,5 | 12,5 |
| | | Length L (with washer 2a) | 52 + t_{fix} | 63 + t_{fix} | 75 + t_{fix} | 90 + t_{fix} | 95 + t_{fix} | 90 + t_{fix} | 100 + t_{fix} | 115 + t_{fix} | 120 + t_{fix} | 130 + t_{fix} | 145 + t_{fix} |
| | | Reduction $t_{fix}^{(1)}$ (with filling washer 2b) | 3,4 | 3,4 | 3 | 3 | 2,5 | 2,5 | 2,5 | 2,5 | 2,5 | 2,5 | 2,5 |
| 3 | Hexagon nut SW | 13 | 13 | 17 | 17 | 19 | 19 | 19 | 19 | 19 | 19 | 19 | |

¹⁾ When using filling washer (2b) the thickness of fixture is reduced by the specified value.

Dimensions in mm

Table A3: Dimensions of anchor rod, AX XTREME ETA 1 M16 – M24

| Anchor size | AX XTREME ETA 1 | 90 M16 | 105 M16 | 125 M16 | 145 M16 | 160 M16 | 115 M20 | 170 M20 (LG) | 190 M20 (LG) | 170 M24 (LG) | 200 M24 (LG) | 225 M24 (LG) | |
|--------------------|-----------------|---|--------------------|--------------------|--------------------|--------------------|--------------------|--------------------|--------------------|--------------------|--------------------|--------------------|--------------------|
| Additional marking | | 1 | 2 | 3 | 4 | 5 | 1 | 2 | 3 | 1 | 2 | 3 | |
| 1 | Anchor rod | Thread | M16 | | | | M20 | | | M24 | | | |
| | | Number of cones | 3 | 4 | 6 | 6 | 6 | 3 | 6 | 6 | 6 | 6 | 6 |
| | | $d_k =$ | 16,5 | 16,5 | 16,5 | 16,5 | 16,5 | 19,7 | 22,0 | 22,0 | 24,0 | 24,0 | 24,0 |
| | | Length L (with washer 2a) | 114 + t_{fix} | 129 + t_{fix} | 150 + t_{fix} | 170 + t_{fix} | 185 + t_{fix} | 143 + t_{fix} | 203 + t_{fix} | 223 + t_{fix} | 210 + t_{fix} | 240 + t_{fix} | 265 + t_{fix} |
| | | Reduction $t_{fix}^{(1)}$ (with filling washer 2b) | 2 | 2 | 2 | 2 | 2 | 2 | 2 | 2 | 2 | 2 | 2 |
| 3 | Hexagon nut SW | 24 | 24 | 24 | 24 | 24 | 30 | 30 | 30 | 36 | 36 | 36 | |

¹⁾ When using filling washer (2b) the thickness of fixture is reduced by the specified value.

Dimensions in mm

Injection System IM XTREME ETA 1

Product description
AX XTREME ETA 1: Anchor dimensions

Annex A4

Table A4: Materials AX-I XTREME ETA 1

| Part | Designation | Steel, zinc plated ≥ 5µm | Stainless steel A4 (CRC III) | High corrosion resistant steel HCR (CRC V) |
|------|---------------------|--|---|---|
| 1 | Anchor rod | Steel acc. to EN ISO 683-4:2018, galvanized and coated | Stainless steel, 1.4401, 1.4404, 1.4571 acc. to EN 10088:2023, coated | High corrosion resistant steel 1.4529, 1.4565 acc. to EN 10088:2023, coated |
| 4 | Mortar cartridge | Vinylester resin, styrene free, mixing ratio 1:10 | | |

Marking: e.g. \diamond 80 VMZ M10

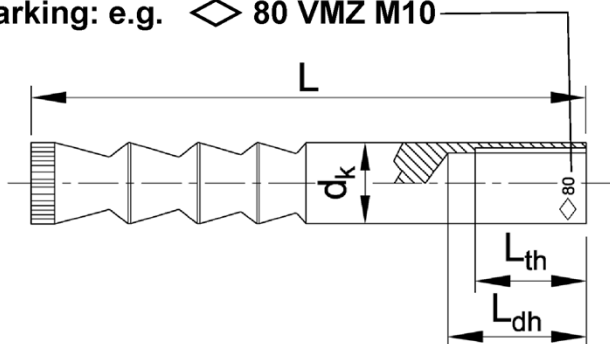

- \diamond identifying mark of manufacturing plant
- 80 anchorage depth
- VMZ fastener identity
- M10 size of internal thread
- A4 additional marking of stainless steel
- HCR additional marking of high corrosion resistant steel

Table A5: Dimensions of anchor rod AX-I XTREME ETA 1

| Anchor size | AX-I XTREME ETA 1 | 40 M6 | 50 M6 | 60 M8 | 75 M8 | 70 M10 | 80 M10 | 90 M12 | 105 M12 | 125 M12 | 115 M16 | 170 M16 | 170 M20 |
|-------------------|-------------------|------------------|------------------|--------------------|--------------------|------------------|------------------|--------------------|--------------------|------------------------------|------------------|---------------|------------|
| Internal thread | - | M6 | | M8 | | M10 | | M12 | | | M16 | | M20 |
| Number of cones | - | 2 | 3 | 3 | 3 | 3 | 4 | 3 | 4 | 6 | 3 | 6 | 6 |
| Outer diameter | d_k [mm] | 8,0 | 8,0 | 9,7 | 10,7 | 12,5 | 12,5 | 16,5 | 16,5 | 16,5 | 19,7 | 22,0 | 24,0 |
| Thread length | L_{th} [mm] | 12 | 15 | 16 | 19 | 20 | 23 | 24 | 27 | 30 | 32 | 32 | 40 |
| Total length | L [mm] | 41 | 52 | 63 | 78 | 74 | 84 | 94 | 109 | 130 | 120 | 180 | 182 |
| Length identifier | [mm] | L_{dh} < 18 | L_{dh} > 19 | L_{dh} < 22,5 | L_{dh} > 23,5 | L_{dh} < 27 | L_{dh} > 28 | L_{dh} < 31,5 | L_{dh} < 34,5 | 32,5 < L_{dh} > 35,5 | L_{dh} < 21 | d_k > 21 | - |

Requirements of the fastening screw or the threaded rod and nut

- Minimum screw-in depth L_{smin} see Table B7
- The length of screw or the threaded rod must depending on the thickness of fixture t_{fix} , available thread length L_{th} (=maximum available thread length, see Table B7) and the minimum screw-in depth L_{smin} be established
- $A_5 > 8\%$ ductility
- Material
 - **Steel, zinc plated:** Minimum property class 8.8 according to EN ISO 898-1:2013 or EN ISO 898-2:2022
 - **Stainless steel A4 or high corrosion resistant steel (HCR):** Minimum property class 70 according to EN ISO 3506-1:2020 or according to EN ISO 3506-2:2020

Injection System IM XTREME ETA 1

Product description
AX-I XTREME ETA 1: Werkstoffe, Prägung, Abmessungen

Annex A5

Specifications of intended use

| Injection System IM XTREME ETA 1 | | | | | | | |
|---|---|---|-----------------|-----------------|-----|-----|-----|
| Static and quasi-static action | AX XTREME ETA 1 | M8 | M10 | M12 | M16 | M20 | M24 |
| | AX-I XTREME ETA 1 | M6 | M8 | M10 | M12 | M16 | M20 |
| Base materials | | cracked concrete uncracked concrete | | | | | |
| | | Concrete strength classes C20/25 to C90/105 , without fibres Concrete strength classes C20/25 to C90/105 , with fibres | | | | | |
| Drilling method | Hammer drill bit (HD) | ✓ | ✓ | ✓ | ✓ | ✓ | ✓ |
| | Vacuum drill bit ³⁾ (VD) | - ¹⁾ | ✓ | ✓ | ✓ | ✓ | ✓ |
| | Diamond drill bit (DD) (C20/25 - C50/60; without fibres) | - ¹⁾ | ✓ | ✓ | ✓ | ✓ | ✓ |
| Seismic action | VMZ-A | M8 | M10 | M12 | M16 | M20 | M24 |
| Performance Category | | C1 and C2 | | | | | |
| Base materials | | cracked concrete uncracked concrete | | | | | |
| | | Concrete strength classes C20/25 to C50/60 , without fibres | | | | | |
| Drilling method | Hammer drill bit (HD) | - ¹⁾ | ✓ | ✓ | ✓ | ✓ | ✓ |
| | Vacuum drill bit ³⁾ (VD) | - ¹⁾ | ✓ | ✓ | ✓ | ✓ | ✓ |
| | Diamond drill bit (DD) | No performance assessed | | | | | |
| Installation | AX XTREME ETA 1 | M8 | M10 | M12 | M16 | M20 | M24 |
| | AX-I XTREME ETA 1 | M6 | M8 | M10 | M12 | M16 | M20 |
| Dry concrete | | ✓ | ✓ | ✓ | ✓ | ✓ | ✓ |
| Wet concrete | | ✓ | ✓ | ✓ | ✓ | ✓ | ✓ |
| Water-filled hole | | - ¹⁾ | - ¹⁾ | ✓ ²⁾ | ✓ | ✓ | ✓ |
| Overhead installation | | ✓ | ✓ | ✓ | ✓ | ✓ | ✓ |
| Pre-setting installation | | ✓ | ✓ | ✓ | ✓ | ✓ | ✓ |
| Through-setting installation (AX XTREME ETA 1) | | - ¹⁾ | ✓ | ✓ | ✓ | ✓ | ✓ |
| Temperature Range | | | | | | | |
| I: -40°C to +80°C | | max. long term temperature +50°C and max. short term temperature +80°C | | | | | |
| II: -40°C to +120°C | | max. long term temperature +72°C and max. short term temperature +120°C | | | | | |

¹⁾ No performance assessed

²⁾ Exception: AX XTREME ETA 1 75 M12 (Installation in water-filled drill hole is not allowed)

³⁾ e.g. MKT vacuum drill bit, Würth hammer drill bit with suction or Heller Duster Expert

Injection System IM XTREME ETA 1

Intended use
Specifications and installation conditions

Annex B1

Specifications of intended use

Base material:

- Compacted, reinforced or unreinforced normal weight concrete with strength classes C20/25 to C90/105 acc. to EN 206:2013+A2:2021
- Steel fiber reinforced concrete according to EN 206:2013+A2:2021. with steel fibers according to EN 14889-1:2006, section 5, group 1, with a maximum fiber content of 80kg/m³

Use conditions (Environmental conditions):

- Structures subject to dry internal conditions: all versions AX XTREME ETA 1 and AX-I XTREME ETA 1
- For all other conditions:
Intended use of materials according to Annex A3, Table A1 and Annex A5, Table A4 corresponding to the corrosion resistance class CRC acc. to EN 1993-1-4:2006+A1:2015

Design:

- Anchorages are designed under the responsibility of an engineer experienced in anchorages and concrete work.
- Verifiable calculation notes and drawings are prepared taking account of the loads to be anchored. The position of the anchor is indicated on the design drawings (e.g. position of the anchor relative to reinforcement or to supports, etc.).
- Anchorages are designed in accordance with EN 1992-4:2018 and Technical Report TR 055, Edition February 2018

Installation:

- Drill hole must be cleaned directly prior to installation of the anchor or the drill hole has to be protected against re-contamination in an appropriate way until dispensing the mortar in the drill hole.
- Water filled drill holes must not be polluted – otherwise the cleaning of the drill hole must be repeated.
- The anchor component installation temperature shall be at least +5 °C; during curing of the injection mortar the temperature of the concrete must not fall below -15 °C (for the standard variation of temperature after installation).
- It must be ensured that icing does not occur in the drill hole.
- Optionally, the annular gap between anchor rod and fixture may be filled with injection adhesive IM XTREME ETA 1 using the filling washer (Part 2b, Annex A3) instead of the washer (Part 2a, Annex A3).

Injection System IM XTREME ETA 1

**Intended use
Specifications**

Annex B2

Table B1: Working and curing time IM XTREME ETA 1

| Temperature in the drill hole | Maximum working time | Minimum curing time dry concrete ¹⁾ |
|-------------------------------|----------------------|--|
| - 15 °C to - 10 °C | 45 min | 7 d |
| - 9 °C to - 5 °C | 45 min | 10:30 h |
| - 4 °C to - 1 °C | 45 min | 6:00 h |
| 0 °C to + 4 °C | 20 min | 3:00 h |
| +5 °C to + 9 °C | 12 min | 2:00 h |
| +10 °C to +19 °C | 6 min | 1:20 h |
| +20 °C to +29 °C | 4 min | 45 min |
| +30 °C to +34 °C | 2 min | 25 min |
| +35 °C to +39 °C | 1,4 min | 20 min |
| + 40 °C | 1,4 min | 15 min |
| Cartridge temperature | ≥ 5° C | |

¹⁾ Curing time in wet concrete shall be doubled.

Table B2: Working and curing time IM XTREME ETA 1 express

| Temperature in the drill hole | Maximum working time | Minimum curing time dry concrete ¹⁾ |
|-------------------------------|----------------------|--|
| - 5 °C to - 1 °C | 20 min | 4:00 h |
| 0 °C to + 4 °C | 10 min | 2:00 h |
| + 5 °C to + 9 °C | 6 min | 1:00 h |
| +10 °C to +19 °C | 3 min | 40 min |
| +20 °C to +29 °C | 1 min | 20 min |
| + 30 °C | 1 min | 10 min |
| Cartridge temperature | ≥ 5° C | |

¹⁾ Curing time in wet concrete shall be doubled.

I Injection System IM XTREME ETA 1

Intended use
Working and curing time

Annex B3

Table B3: Installation parameters, AX XTREME ETA 1 M8 – M12

| Anchor size | AX XTREME ETA 1 | 40 M8 | 50 M8 | 60 M10 | 75 M10 | 75 M12 | 70 M12 | 80 M12 | 95 M12 | 100 M12 | 110 M12 | 125 M12 |
|---|----------------------|------------------|------------------|--------|--------|-----------------------|--------|--------|--------|---------|---------|---------|
| Effective anchorage depth | $h_{ef} \geq$ [mm] | 40 | 50 | 60 | 75 | 75 | 70 | 80 | 95 | 100 | 110 | 125 |
| Nominal diameter of drill hole | $d_0 =$ [mm] | 10 | 10 | 12 | 12 | 12 | 14 | 14 | 14 | 14 | 14 | 14 |
| Depth of drill hole | $h_0 \geq$ [mm] | 42 | 55 | 65 | 80 | 80 | 75 | 85 | 100 | 105 | 115 | 130 |
| Diameter of cleaning brush | $D \geq$ [mm] | 10,8 | 10,8 | 13,0 | 13,0 | 13,0 | 15,0 | 15,0 | 15,0 | 15,0 | 15,0 | 15,0 |
| Installation torque | $T_{inst} \leq$ [Nm] | 10 ¹⁾ | 10 ¹⁾ | 15 | 15 | 25 | 25 | 25 | 25 | 30 | 30 | 30 |
| Diameter of clearance hole in the fixture | | | | | | | | | | | | |
| Pre-setting installation | $d_f \leq$ [mm] | 9 | 9 | 12 | 12 | 14 | 14 | 14 | 14 | 14 | 14 | 14 |
| Through-setting installation | $d_f \leq$ [mm] | - ²⁾ | - ²⁾ | 14 | 14 | 14 ³⁾ / 16 | 16 | 16 | 16 | 16 | 16 | 16 |

1) AX XTREME ETA 1 M8: $T_{inst} = 10Nm$

2) No performance assessed

3) See Annex B11

Table B4: Installation parameters, AX XTREME ETA 1 M16 – M24

| Anchor size | AX XTREME ETA 1 | 90 M16 | 105 M16 | 125 M16 | 145 M16 | 160 M16 | 115 M20 | 170 M20 (LG) | 190 M20 (LG) | 170 M24 (LG) | 200 M24 (LG) | 225 M24 (LG) |
|---|----------------------|--------|---------|---------|---------|---------|---------|--------------|--------------|--------------|--------------|--------------|
| Effective anchorage depth | $h_{ef} \geq$ [mm] | 90 | 105 | 125 | 145 | 160 | 115 | 170 | 190 | 170 | 200 | 225 |
| Nominal diameter of drill hole | $d_0 =$ [mm] | 18 | 18 | 18 | 18 | 18 | 22 | 24 | 24 | 26 | 26 | 26 |
| Depth of drill hole | $h_0 \geq$ [mm] | 98 | 113 | 133 | 153 | 168 | 120 | 180 | 200 | 185 | 215 | 240 |
| Diameter of cleaning brush | $D \geq$ [mm] | 19,0 | 19,0 | 19,0 | 19,0 | 19,0 | 23,0 | 25,0 | 25,0 | 27,0 | 27,0 | 27,0 |
| Installation torque | $T_{inst} \leq$ [Nm] | 50 | 50 | 50 | 50 | 50 | 80 | 80 | 80 | 100 | 120 | 120 |
| Diameter of clearance hole in the fixture | | | | | | | | | | | | |
| Pre-setting installation | $d_f \leq$ [mm] | 18 | 18 | 18 | 18 | 18 | 22 | 24 (22) | 24 (22) | 26 | 26 | 26 |
| Through-setting installation | $d_f \leq$ [mm] | 20 | 20 | 20 | 20 | 20 | 24 | 26 | 26 | 28 | 28 | 28 |

Pre-setting installation

Size M8 to M16, Size M20 + M24
M20 LG, M24 LG

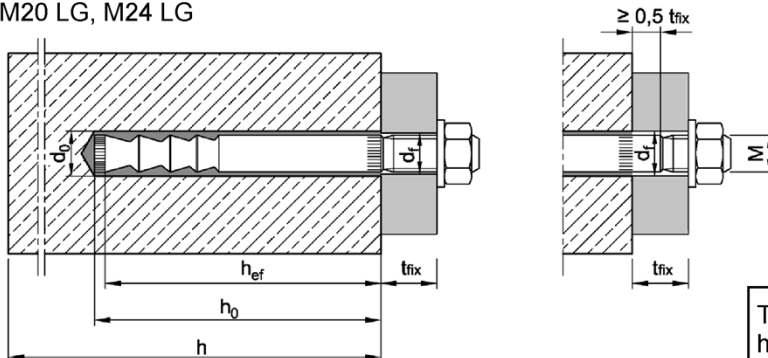

Through-setting installation

Size M10 - M16, Size M20 + M24
M20 LG, M24 LG

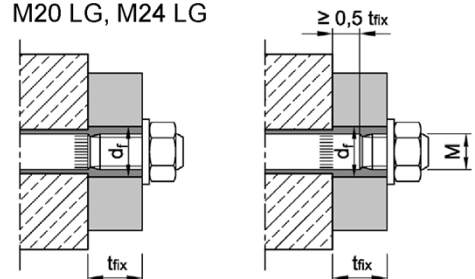

The annular gap in the clearance hole in the fixture has to be filled completely by excess mortar!

Injection System IM XTREME ETA 1

Intended use
Installation parameters AX XTREME ETA 1

Annex B4

Table B5: Minimum spacing and edge distance, AX XTREME ETA 1 M8 – M12

| Anchor size | AX XTREME ETA 1 | 40 M8 | 50 M8 | 60 M10 | 75 M10 | 75 M12 | 70 M12 | 80 M12 | 95 M12 | 100 M12 | 110 M12 | 125 M12 |
|-------------------------------|-----------------|-------|-------|--------|--------------------------|--------|--------|--------|--------------------------|------------------|------------------|------------------|
| Minimum thickness of concrete | h_{min} [mm] | 80 | 80 | 100 | 110 100 ¹⁾ | 110 | 110 | 110 | 130 125 ¹⁾ | 130 | 140 | 160 |
| Cracked concrete | | | | | | | | | | | | |
| Minimum spacing | s_{min} [mm] | 40 | 40 | 40 | 40 | 50 | 55 | 40 | 40 | 50 | 50 | 50 |
| Minimum edge distance | c_{min} [mm] | 40 | 40 | 40 | 40 | 50 | 55 | 50 | 50 | 50 | 50 | 50 |
| Uncracked concrete | | | | | | | | | | | | |
| Minimum spacing | s_{min} [mm] | 40 | 40 | 50 | 50 | 50 | 55 | 55 | 55 | 80 ²⁾ | 80 ²⁾ | 80 ²⁾ |
| Minimum edge distance | c_{min} [mm] | 40 | 40 | 50 | 50 | 50 | 55 | 55 | 55 | 55 ²⁾ | 55 ²⁾ | 55 ²⁾ |

¹⁾ The reverse of the concrete member must not be damaged after drilling and must be filled with high-strength mortar if drilled through.

²⁾ For an edge distance $c \geq 80$ mm a minimum spacing $s_{min} = 55$ mm is applicable.

Table B6: Minimum spacing and edge distance, AX XTREME ETA 1 M16 – M24

| Anchor size | AX XTREME ETA 1 | 90 M16 | 105 M16 | 125 M16 | 145 M16 | 160 M16 | 115 M20 | 170 M20 (LG) | 190 M20 (LG) | 170 M24 (LG) | 200 M24 (LG) | 225 M24 (LG) |
|-------------------------------|-----------------|--------|---------|--------------------------|--------------------------|--------------------------|---------|--------------------------|--------------------------|--------------------------|--------------------------|--------------------------|
| Minimum thickness of concrete | h_{min} [mm] | 130 | 150 | 170 160 ¹⁾ | 190 180 ¹⁾ | 205 200 ¹⁾ | 160 | 230 220 ¹⁾ | 250 240 ¹⁾ | 230 220 ¹⁾ | 270 260 ¹⁾ | 300 290 ¹⁾ |
| Cracked concrete | | | | | | | | | | | | |
| Minimum spacing | s_{min} [mm] | 50 | 50 | 60 | 60 | 60 | 80 | 80 | 80 | 80 | 80 | 80 |
| Minimum edge distance | c_{min} [mm] | 50 | 50 | 60 | 60 | 60 | 80 | 80 | 80 | 80 | 80 | 80 |
| Uncracked concrete | | | | | | | | | | | | |
| Minimum spacing | s_{min} [mm] | 50 | 60 | 60 | 60 | 60 | 80 | 80 | 80 | 80 | 105 | 105 |
| Minimum edge distance | c_{min} [mm] | 50 | 60 | 60 | 60 | 60 | 80 | 80 | 80 | 80 | 105 | 105 |

¹⁾ The reverse of the concrete member must not be damaged after drilling and must be filled with high-strength mortar if drilled through.

I Injection System IM XTREME ETA 1

Intended use
Minimum spacing and edge distance, AX XTREME ETA 1

Annex B5

Table B7: Installation parameters AX-I XTREME ETA 1

| Anchor size | AX-I XTREME ETA 1 | 40 M6 | 50 M6 | 60 M8 | 75 M8 | 70 M10 | 80 M10 | 90 M12 | 105 M12 | 125 M12 | 115 M16 | 170 M16 | 170 M20 |
|---|----------------------|-------|-------|-------|-------|--------|--------|--------|---------|--------------------------|---------|--------------------------|--------------------------|
| Effective anchorage depth | h_{ef} [mm] | 40 | 50 | 60 | 75 | 70 | 80 | 90 | 105 | 125 | 115 | 170 | 170 |
| Nominal diameter of drill hole | d_0 [mm] | 10 | 10 | 12 | 12 | 14 | 14 | 18 | 18 | 18 | 22 | 24 | 26 |
| Depth of drill hole | $h_0 \geq$ [mm] | 42 | 55 | 65 | 80 | 80 | 85 | 98 | 113 | 133 | 120 | 180 | 185 |
| Diameter of cleaning brush | $D \geq$ [mm] | 10,8 | 10,8 | 13,0 | 13,0 | 15,0 | 15,0 | 19,0 | 19,0 | 19,0 | 23,0 | 25,0 | 27,0 |
| Installation torque | $T_{inst} \leq$ [Nm] | 8 | 8 | 10 | 10 | 15 | 15 | 25 | 25 | 25 | 50 | 50 | 80 |
| Diameter of clearance hole in the fixture | $d_f \leq$ [mm] | 7 | 7 | 9 | 9 | 12 | 12 | 14 | 14 | 14 | 18 | 18 | 22 |
| Available thread length | L_{th} [mm] | 12 | 15 | 16 | 19 | 20 | 23 | 24 | 27 | 30 | 32 | 32 | 40 |
| Minimum screw-in depth | L_{sdmin} [mm] | 7 | 7 | 9 | 9 | 12 | 12 | 14 | 14 | 14 | 18 | 18 | 22 |
| Minimum thickness of concrete | h_{min} [mm] | 80 | 80 | 100 | 110 | 110 | 110 | 130 | 150 | 170 160 ¹⁾ | 160 | 230 220 ¹⁾ | 230 220 ¹⁾ |
| Cracked concrete | | | | | | | | | | | | | |
| Minimum spacing | s_{min} [mm] | 40 | 40 | 40 | 40 | 55 | 40 | 50 | 50 | 60 | 80 | 80 | 80 |
| Minimum edge distance | c_{min} [mm] | 40 | 40 | 40 | 40 | 55 | 50 | 50 | 50 | 60 | 80 | 80 | 80 |
| Uncracked concrete | | | | | | | | | | | | | |
| Minimum spacing | s_{min} [mm] | 40 | 40 | 50 | 50 | 55 | 55 | 50 | 60 | 60 | 80 | 80 | 80 |
| Minimum edge distance | c_{min} [mm] | 40 | 40 | 50 | 50 | 55 | 55 | 50 | 60 | 60 | 80 | 80 | 80 |

¹⁾ The reverse of the concrete member must not be damaged after drilling and must be filled with high-strength mortar if drilled through.

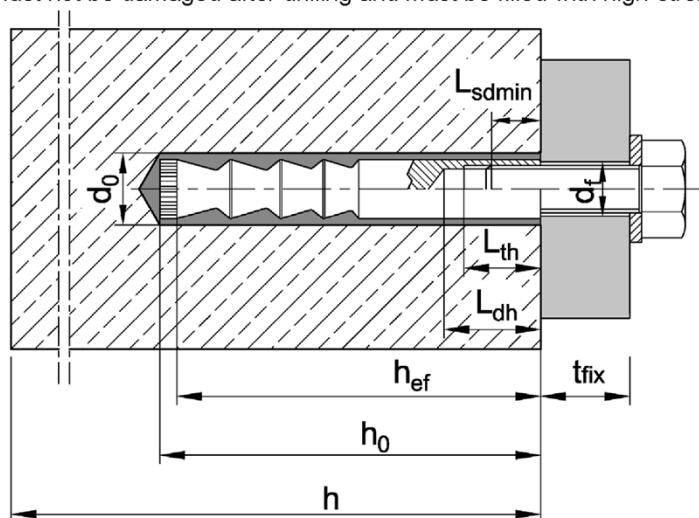



Injection System IM XTREME ETA 1

Intended use
Installation parameters **AX-I XTREME ETA 1**

Annex B6

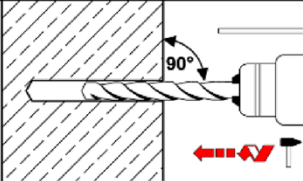
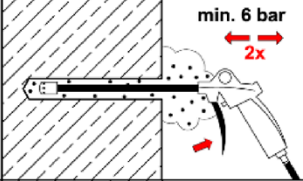
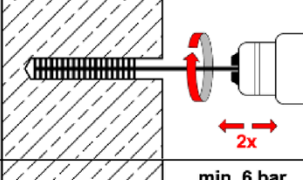
Installation instructions - Hammer drill bit

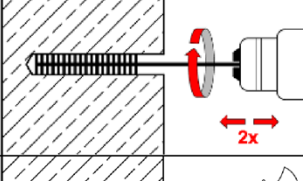
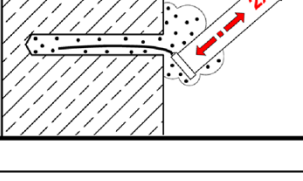
| Hammer drill bit | | |
|---|---|---|
| Hole drilling | | |
| 1 |  | Use hammer drill or compressed air drill with drill bit and depth gauge. Drill perpendicular to concrete surface. |
| Cleaning | | |
| Cleaning with compressed air (all sizes) | | |
| 2a |  | Connect Air Blower to compressed air (min. 6 bar, oil-free). Open air valve and blow out drill hole along the entire depth with back-and-forth motion at least two times. |
| 3a |  | Check diameter of cleaning brush. If the brush can be pushed into the drill hole without any resistance, it must be replaced. Chuck brush into drill machine. Turn on drill machine and brush drill hole back and forth along the entire drill hole depth at least two times while rotated by drill machine. |
| 4a |  | Connect Air Blower to compressed air (min. 6 bar, oil-free). Open air valve and blow out drill hole along the entire depth with back-and-forth motion at least two times. |
| Manual cleaning (alternatively, up to drill hole diameter 18mm) | | |
| 2b |  | Blow out drill hole from the bottom with Blow-out pump at least two times. |
| 3b |  | Check diameter of cleaning brush. If the brush can be pushed into the drill hole without any resistance, it must be replaced. Chuck brush into drill machine. Turn on drill machine and brush drill hole back and forth along the entire drill hole depth at least two times while rotated by drill machine. |
| 4b |  | Blow out drill hole from the bottom with Blow-out pump at least two times. |

I Injection System IM XTREME ETA 1

Intended use

Installation instructions
Hole drilling and cleaning (hammer drill bit)

Annex B7

Installation instructions - Vacuum drill bit

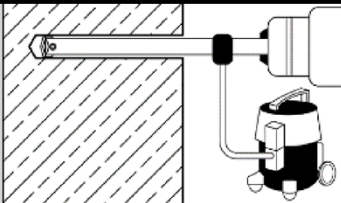
| Vacuum drill bit | |
|--|--|
| Hole drilling and cleaning | |
| 1 |  <p>Drill hole perpendicular to concrete surface by using a vacuum drill bit (see Annex B1). The nominal under pressure of the vacuum cleaner must be at least 230 mbar / 23kPa. Pay attention to the function of the dust extraction system! Make sure the dust extraction is working properly throughout the whole drilling process.</p> |
| Additional cleaning is not necessary - continue with step 5! | |

Installation instructions - Diamond drilling

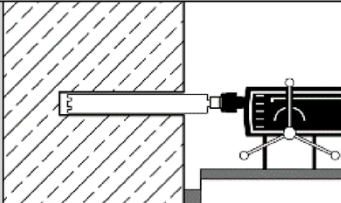
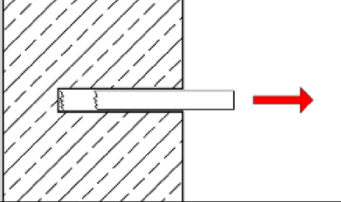
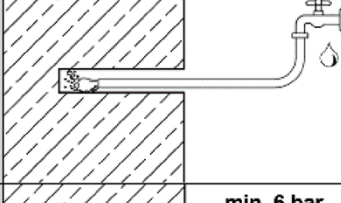
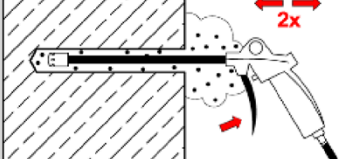
| Diamond drilling | |
|------------------|--|
| Hole drilling | |
| 1 |  <p>Use diamond drill with diamond drill bit and depth gauge. Drill perpendicular to concrete surface.</p> |
| Cleaning | |
| 2 |  <p>Remove drill core at least up to the nominal hole depth and check drill hole depth.</p> |
| 3 |  <p>Flushing of drill hole: Flush drill hole with water, starting from the bottom, until clear water gets out of the drill hole.</p> |
| 4 |  <p>min. 6 bar 2x</p> <p>Connect Air Blower to compressed air (min. 6 bar, oil-free). Open air valve and blow out drill hole along the entire depth with back-and-forth motion at least two times.</p> |

Injection System IM XTREME ETA 1

Intended use
Installation instructions
Hole drilling and cleaning (vacuum drill bit and diamond drill bit)

Annex B8

Installation instructions - Continuation

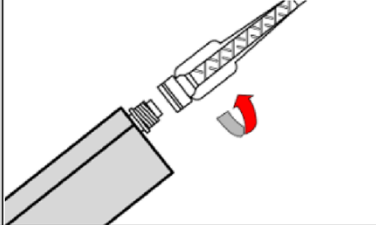
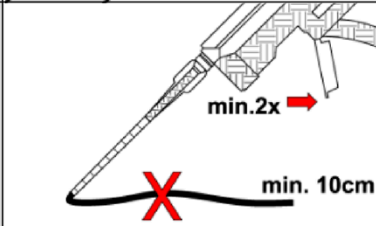
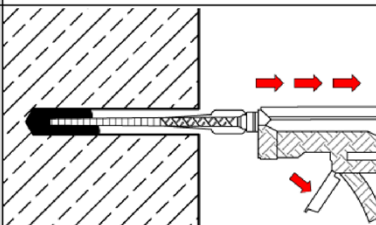
| Injection | | |
|-----------|--|---|
| 5 |  | <p>Check the expiration date on cartridge. Never use when expired. Remove cap from cartridge. Attach the supplied static mixer to the cartridge. For every working interruption longer than the recommended working time (Table B1 or Table B2) as well as for a new cartridge, always use a new static mixer. Never use static mixer without helix inside.</p> |
| 6 |  | <p>Insert cartridge in Dispenser. Before injecting discard mortar (at least 2 full strokes or a line of 10 cm) until it shows a consistent grey colour. Never use this mortar.</p> |
| 7 |  | <p>Prior to injection, check if static mixer reaches the bottom of the drill hole. If it does not reach the bottom, plug Mixer Extension onto static mixer to fill the drill hole properly. Fill hole with a sufficient quantity of injection mortar. Start from the bottom of the drill hole and work out to avoid trapping air pockets.</p> |

Injection System IM XTREME ETA 1

Intended use
Installation instructions
Injection

Annex B9

Installation instructions - Continuation

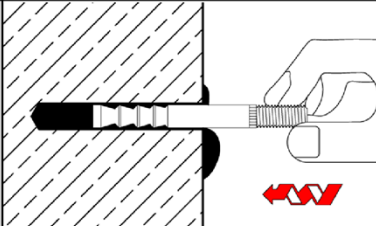
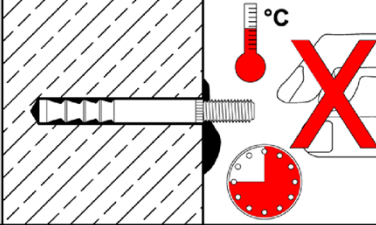
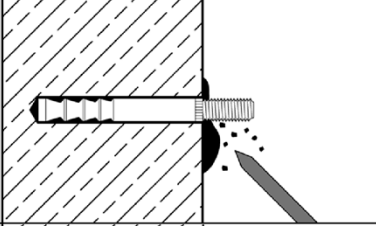
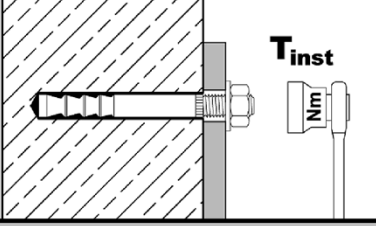
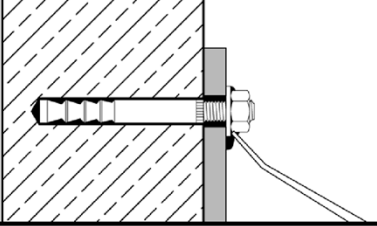
| Anchor rod AX XTREME ETA 1 | | |
|----------------------------|---|--|
| Inserting the anchor rod | | |
| 8 |  | Insert the anchor rod AX XTREME ETA 1 by hand, rotating slightly up to the full embedment depth as marked on the anchor rod. The anchor rod is properly set when excess mortar seeps from the hole (Pre-setting installation) or the annular gap in the clearance hole in the fixture is completely filled by excess mortar (Through-setting installation). If the hole is not completely filled, pull out anchor rod, let mortar cure, drill out hole and repeat the entire cleaning process. |
| 9 |  | Follow minimum curing time shown in Table B1 or Table B2. During curing time, anchor rod must not be moved or loaded. |
| 10 |  | Remove excess mortar. |
| 11 |  | The fixture can be mounted after curing time. Apply installation torque T_{inst} according to Table B3 or Table B4 by using torque wrench. |
| Filling annular gap | | |
| Optional |  | Annular gap between anchor rod and attachment may optionally be filled with mortar. Therefore, replace regular washer by filling washer and plug on reducing adapter on static mixer. Annular gap is completely filled, when excess mortar seeps out. |

Injection System IM XTREME ETA 1

Intended use
Installation instructions
Installation Anchor rod AX XTREME ETA 1

Annex B10

Installation instructions – Stand-off Installation

Stand-off installation with anchor rod AX XTREME ETA 1 75 M12

Requirement: Diameter of clearance hole in the fixture $d_f \leq 14$ mm

Work step 1-7 as illustrated in Annexes B7 – B9

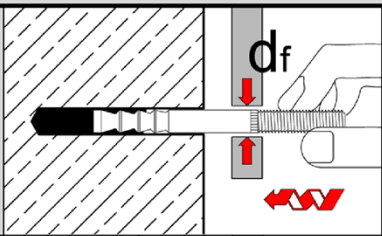
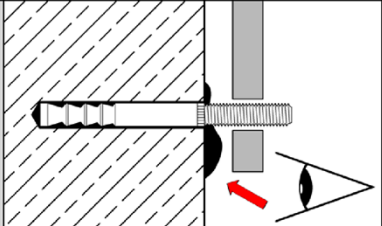
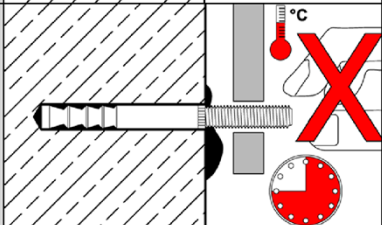
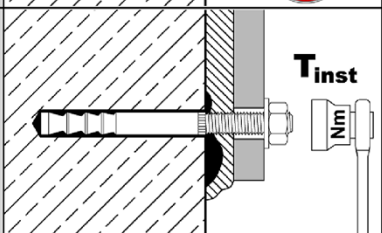
| | | |
|----|---|--|
| 8 |  | <p>Insert the anchor rod AX XTREME ETA 1 by hand, rotating slightly up to the full embedment depth.</p> |
| 9 |  | <p>Check if excess mortar seeps from the hole. If the hole is not completely filled, pull out anchor rod, let mortar cure, drill out hole and repeat the entire cleaning process.</p> <p>The annular gap in the fixture does not have to be filled.</p> |
| 10 |  | <p>During curing time according to Table B1 or Table B2 anchor rod must not be moved or loaded.</p> |
| 11 |  | <p>Washer and nut can be mounted after curing time and backfilling of anchor plate. Apply installation torque T_{inst} according to Table B3 by using torque wrench.</p> |

I Injection System IM XTREME ETA 1

Intended use

Installation instructions AX XTREME ETA 1 75 M12

Through-setting installation with clearance between concrete and anchor plate

Annex B11

Installation instructions - Continuation

Anchor rod AX-I XTREME ETA 1

Setting of anchor rod

Work step 1-7 as illustrated in Annexes B7 – B9

| | | |
|----|--|--|
| 8 | | Insert the anchor rod AX-I XTREME ETA 1 by hand, rotating slightly up to about 1 mm below the concrete surface in the drill hole. The anchor rod is properly set when excess mortar seeps from the hole. If the hole is not completely filled, pull out anchor rod, let mortar cure, drill out hole and repeat the entire cleaning process. |
| 9 | | Follow minimum curing time shown in Table B1 and Table B2. During curing time anchor rod must not be moved or loaded. |
| 10 | | Remove excess mortar. |
| 11 | | The fixture can be mounted after curing time. Apply installation torque T_{inst} according to Table B7 by using torque wrench. |

I Injection System IM XTREME ETA 1

Intended use
Installation instructions
Anchor installation **AX-I XTREME ETA 1**

Annex B12

Table C1: Characteristic values for concrete failure and splitting

| Anchor size | | AX XTREME ETA 1 AX-I XTREME ETA 1 | | all sizes |
|---|---------------------------|--------------------------------------|------|-----------------------------------|
| Concrete cone failure | | | | |
| Factor for | <u>uncracked</u> concrete | $k_{ucr,N}$ | [-] | 11,0 |
| | <u>cracked</u> concrete | $k_{cr,N}$ | [-] | 7,7 |
| Characteristic edge distance | | $c_{cr,N}$ | [mm] | $1,5 \cdot h_{ef}$ |
| Characteristic spacing | | $s_{cr,N}$ | [mm] | $2 \cdot c_{cr,N}$ |
| Splitting | | | | |
| For each proof of splitting failure, $N_{RK,sp}$ shall be calculated according to EN 1992-4:2018, equation (7.23). The higher value for $N_{RK,sp}$ of case 1 and case 2 may be applied for the design. | | | | |
| Case 1 | | | | |
| Characteristic resistance | | $N^0_{RK,sp}$ | [kN] | see following tables |
| Characteristic edge distance | | $c_{cr,sp}$ | [mm] | $1,5 \cdot h_{ef}$ |
| Characteristic spacing | | $s_{cr,sp}$ | [mm] | $2 \cdot c_{cr,sp}$ |
| Case 2 | | | | |
| Characteristic resistance | | $N^0_{RK,sp}$ | [kN] | min [$N_{RK,p}$; $N^0_{RK,c}$] |
| Characteristic edge distance | | $c_{cr,sp}$ | [mm] | see following tables |
| Characteristic spacing | | $s_{cr,sp}$ | [mm] | $2 \cdot c_{cr,sp}$ |

Injection System IM XTREME ETA 1

Performance

Characteristic values for **concrete failure and splitting, AX XTREME ETA 1 and AX-I XTREME ETA 1**

Annex C1

Table C2: Characteristic values for tension loads, AX XTREME ETA 1 M8 – M12, static and quasi-static action

| Anchor size | | AX XTREME ETA 1 | 40 M8 | 50 M8 | 60 M10 | 75 M10 | 75 M12 | 70 M12 | 80 M12 | 95 M12 | 100 M12 | 110 M12 | 125 M12 | |
|---|----------------------------|-----------------|--|--------------|--------------|--------------|--------------|--------------|--------------|------------|------------|--------------|------------|------|
| Installation factor | γ_{inst} | [-] | 1,0 | | | | | | | | | | | |
| Steel failure | | | | | | | | | | | | | | |
| Characteristic resistance | $N_{Rk,s}$ | [kN] | 15 | 18 | 25 | 35 | 49 | 54 | 57 | | | | | |
| Partial factor | γ_{Ms} | [-] | 1,5 | | | | | | | | | | | |
| Pull-out | | | | | | | | | | | | | | |
| Characteristic resistance (concrete C20/25) | | | | | | | | | | | | | | |
| uncracked concrete | 50°C / 80°C ¹⁾ | $N_{Rk,p}$ | [kN] | 9,0 | 17,4 | 22,9 | 32,0 | 32,0 | 28,8 | 35,2 | 40,0 | 49,2 | 50,0 | 50,0 |
| | 72°C / 120°C ¹⁾ | | [kN] | 6 | 9 | 16 | 16 | 16 | 16 | 25 | 25 | 30 | 30 | 30 |
| cracked concrete | 50°C / 80°C ¹⁾ | $N_{Rk,p}$ | [kN] | 8,7 | 12,2 | 16,0 | 22,4 | 22,4 | 20,2 | 24,6 | 31,9 | 34,4 | 39,7 | 48,1 |
| | 72°C / 120°C ¹⁾ | | [kN] | 5 | 7,5 | 12 | 12 | 12 | 16 | 20 | 20 | 30 | 30 | 30 |
| Splitting | | | | | | | | | | | | | | |
| Splitting for standard thickness of concrete member | | | | | | | | | | | | | | |
| Standard thickness of concrete | $h_{min,1} \geq$ | [mm] | 100 | 120 | 150 | 150 | 140 | 160 | 190 | 200 | 220 | 250 | | |
| Case 1 | | | | | | | | | | | | | | |
| Characteristic resistance (concrete C20/25) | $N^0_{Rk,sp}$ | [kN] | 7,5 | 9,0 | 16,0 | 20,0 | 20,0 | 35,2 | 30,0 | 40,0 | | | | |
| Case 2 | | | | | | | | | | | | | | |
| Characteristic edge distance | $c_{cr,sp}$ | [mm] | 3 h_{ef} | 2,5 h_{ef} | 3,5 h_{ef} | 3,5 h_{ef} | 2,5 h_{ef} | 1,5 h_{ef} | 2,5 h_{ef} | 2 h_{ef} | 3 h_{ef} | 2,5 h_{ef} | | |
| Splitting for minimum thickness of concrete member | | | | | | | | | | | | | | |
| Minimum thickness of concrete | $h_{min,2} \geq$ | [mm] | 80 | 100 | 110 | | | 125 | 130 | 140 | 160 | | | |
| Case 1 | | | | | | | | | | | | | | |
| Characteristic resistance (concrete C20/25) | $N^0_{Rk,sp}$ | [kN] | 7,5 | 2) | 16 | 16 | 20 | 25 | 25 | 30 | | | | |
| Case 2 | | | | | | | | | | | | | | |
| Characteristic edge distance | $c_{cr,sp}$ | [mm] | 3 h_{ef} | 3,5 h_{ef} | 3 h_{ef} | 3,5 h_{ef} | 3,5 h_{ef} | 3 h_{ef} | 3,5 h_{ef} | 3 h_{ef} | | | | |
| Increasing factor for $N_{Rk,p} = \psi_c \cdot N_{Rk,p (C20/25)}$ and $N^0_{Rk,sp} = \psi_c \cdot N^0_{Rk,sp (C20/25)}$ ³⁾ | ψ_c | [-] | $\left(\frac{f_{ck}}{20}\right)^{0,5} \leq 1,58$ | | | | | | | | | | | |
| Concrete cone failure | | | | | | | | | | | | | | |
| Effective anchorage depth | h_{ef} | [mm] | 40 | 50 | 60 | 75 | 75 | 70 | 80 | 95 | 100 | 110 | 125 | |

1) Maximum long-term temperature / maximum short-term temperature

2) No performance assessed

3) increasing factor for $N^0_{Rk,sp}$ only for case 1

Injection System IM XTREME ETA 1

Performance

Characteristic values for **tension loads, AX XTREME ETA 1 M8 – M12, static and quasi-static action**

Annex C2

Table C3: Characteristic values for tension loads, AX XTREME ETA 1 M16 – M24, static and quasi-static action

| Anchor size | AX XTREME ETA 1 | 90 M16 | 105 M16 | 125 M16 | 145 M16 | 160 M16 | 115 M20 | 170 M20 (LG) | 190 M20 (LG) | 170 M24 (LG) | 200 M24 (LG) | 225 M24 (LG) | | |
|---|---|--|--------------|--------------|--------------|--------------|---------------|--------------------|--------------------|--------------------|--------------------|--------------------|-------|-------|
| Installation factor | γ_{inst} [-] | 1,0 | | | | | | | | | | | | |
| Steel failure | | | | | | | | | | | | | | |
| Characteristic tension resistance $N_{Rk,s}$ | Steel, zinc plated [kN] | 88 | 95 | 111 | 97 | 96 | 188 | 222 | | | | | | |
| | A4, HCR [kN] | 88 | 95 | 111 | 97 | 114 | 165 | 194 | | | | | | |
| Partial factor | γ_{Ms} [-] | 1,5 | | | | | 1,68 | 1,5 | 1,5 | | | | | |
| Pull-out | | | | | | | | | | | | | | |
| Characteristic resistance (concrete C20/25) | | | | | | | | | | | | | | |
| uncracked concrete | 50°C/80°C ¹⁾ | $N_{Rk,p}$ | [kN] | 42,0 | 52,9 | 68,8 | 75,0 | 90,0 | 60,7 | 109,0 | 128,8 | 109,0 | 139,1 | 166,0 |
| | 72°C/120°C ¹⁾ | | [kN] | 25 | 35 | 50 | 53 | 40 | 75 | 95 | | | | |
| cracked concrete | 50°C/80°C ¹⁾ | $N_{Rk,p}$ | [kN] | 29,4 | 37,1 | 48,1 | 60,1 | 69,7 | 42,5 | 76,3 | 90,2 | 76,3 | 97,4 | 116,2 |
| | 72°C/120°C ¹⁾ | | [kN] | 25 | 30 | 50 | 51 | 30 | 60 | 75 | | | | |
| Splitting | | | | | | | | | | | | | | |
| Splitting for standard thickness of concrete | | | | | | | | | | | | | | |
| Standard thickness of concrete | $h_{min,1} \geq$ [mm] | 180 | 200 | 250 | 290 | 320 | 230 | 340 | 380 | 340 | 400 | 450 | | |
| Case 1 | | | | | | | | | | | | | | |
| Characteristic resistance (concrete C20/25) | $N^0_{Rk,sp}$ [kN] | 40 | 50 | 60 | 80 | 60,7 | 109 | 115 | 109 | 139,1 | 140 | | | |
| Case 2 | | | | | | | | | | | | | | |
| Characteristic edge distance | $c_{cr,sp}$ [mm] | 2 h_{ef} | | | | | 1,5 h_{ef} | 2 h_{ef} | 1,5 h_{ef} | 1,8 h_{ef} | | | | |
| Splitting for minimum thickness of concrete | | | | | | | | | | | | | | |
| Minimum thickness of concrete | $h_{min,2} \geq$ [mm] | 130 | 150 | 160 | 180 | 200 | 160 | 220 | 240 | 220 | 260 | 290 | | |
| Case 1 | | | | | | | | | | | | | | |
| Characteristic resistance (concrete C20/25) | $N^0_{Rk,sp}$ [kN] | 35 | 50 | 40 | 50 | 71 | ²⁾ | 75 | 109 | 115 | | | | |
| Case 2 | | | | | | | | | | | | | | |
| Characteristic edge distance | $c_{cr,sp}$ [mm] | 2,5 h_{ef} | 3,0 h_{ef} | 2,5 h_{ef} | 2,5 h_{ef} | 2,5 h_{ef} | 2,6 h_{ef} | 2,2 h_{ef} | 2,6 h_{ef} | 2,2 h_{ef} | | | | |
| Increasing factor for | $N_{Rk,p} = \psi_c \cdot N_{Rk,p (C20/25)}$ and ψ_c | $\left(\frac{f_{ck}}{20}\right)^{0,5} \leq 1,58$ | | | | | | | | | | | | |
| | $N^0_{Rk,sp} = \psi_c \cdot N^0_{Rk,sp (C20/25)}$ ³⁾ | | | | | | | | | | | | | |
| Concrete cone failure | | | | | | | | | | | | | | |
| Effective anchorage depth | h_{ef} [mm] | 90 | 105 | 125 | 145 | 160 | 115 | 170 | 190 | 170 | 200 | 225 | | |

1) Maximum long-term temperature / Maximum short-term temperature

2) No performance assessed

3) Increasing factor for $N^0_{Rk,sp}$ only for Case 1

Injection System IM XTREME ETA 1

Performance

Characteristic values for **tension loads, AX XTREME ETA 1 M16 – M24, static and quasi-static action**

Annex C3

Table C4: Characteristic values for shear load, AX XTREME ETA 1 M8 – M12, static and quasi-static action

| Anchor size | | AX XTREME ETA 1 | 40 M8 | 50 M8 | 60 M10 | 75 M10 | 75 M12 | 70 M12 | 80 M12 | 95 M12 | 100 M12 | 110 M12 | 125 M12 |
|---|--------------------|-----------------|----------|----------|-----------|-----------|-----------|-----------|-----------|-----------|------------|------------|------------|
| Installation factor | γ_{inst} | [-] | 1,0 | | | | | | | | | | |
| Steel failure <u>without</u> lever arm | | | | | | | | | | | | | |
| Characteristic resistance $V_{RK,S}^0$ | Steel, zinc plated | [kN] | 14 | 21 | | 34 | | | | | | | |
| | A4, HCR | [kN] | 15 | 23 | | 34 | | | | | | | |
| Partial factor | γ_{Ms} | [-] | 1,25 | | | | | | | | | | |
| Ductility factor | k_7 | [-] | 1,0 | | | | | | | | | | |
| Steel failure <u>with</u> lever arm | | | | | | | | | | | | | |
| Characteristic bending resistance $M_{RK,S}^0$ | Steel, zinc plated | [Nm] | 30 | 60 | | 105 | | | | | | | |
| | A4, HCR | [Nm] | 30 | 60 | | 105 | | | | | | | |
| Partial factor | γ_{Ms} | [-] | 1,25 | | | | | | | | | | |
| Concrete pry-out failure | | | | | | | | | | | | | |
| Pry-out factor | k_8 | [-] | 2 | | | | | | | | | | |
| Concrete edge failure | | | | | | | | | | | | | |
| Effective length of anchor in shear load | l_f | [mm] | 40 | 50 | 60 | 75 | 75 | 70 | 80 | 95 | 100 | 110 | 125 |
| Outside diameter of anchor | d_{nom} | [mm] | 10 | | 12 | | 12 | 14 | | | | | |

Injection System IM XTREME ETA 1

Performance

Characteristic values for shear load, AX XTREME ETA 1 M8 – M12, static and quasi-static action

Annex C4

Table C5: Characteristic values for shear load, AX XTREME ETA 1 M16 – M24, static or quasi-static action

| Anchor size | | | 90 | 105 | 125 | 145 | 160 | 115 | 170 | 190 | 170 | 200 | 225 |
|---|--------------------|------|------|-----|-----|-----|-----|-----|---------------------------|-------------|----------------------------|-------------|-------------|
| AX XTREME ETA 1 | | | M16 | M16 | M16 | M16 | M16 | M20 | M20 (LG) | M20 (LG) | M24 (LG) | M24 (LG) | M24 (LG) |
| Installation factor | γ_{inst} | [-] | 1,0 | | | | | | | | | | |
| Steel failure <u>without</u> lever arm | | | | | | | | | | | | | |
| Characteristic resistance $V_{Rk,s}^0$ | Steel, zinc plated | [kN] | 63 | | | | 70 | | 149 ¹⁾ (98) | | 178 ¹⁾ (141) | | |
| | A4, HCR | [kN] | 63 | | | | 86 | | 131 ¹⁾ (86) | | 156 ¹⁾ (123) | | |
| Partial factor | γ_{Ms} | [-] | 1,25 | | | | 1,4 | | 1,25 | | 1,25 | | |
| Ductility factor | k_7 | [-] | 1,0 | | | | | | | | | | |
| Steel failure <u>with</u> lever arm | | | | | | | | | | | | | |
| Characteristic bending resistance $M_{Rk,s}^0$ | Steel, zinc plated | [Nm] | 266 | | | | 392 | | 519 | | 896 | | |
| | A4, HCR | [Nm] | 266 | | | | | | 454 | | 784 | | |
| Partial factor | γ_{Ms} | [-] | 1,25 | | | | 1,4 | | 1,25 | | 1,25 | | |
| Concrete pry-out failure | | | | | | | | | | | | | |
| Pry-out factor | k_8 | [-] | 2,0 | | | | | | | | | | |
| Concrete edge failure | | | | | | | | | | | | | |
| Effective length of anchor in shear load | l_f | [mm] | 90 | 105 | 125 | 145 | 160 | 115 | 170 | 190 | 170 | 200 | 225 |
| Outside diameter of anchor | d_{nom} | [mm] | 18 | | | | 22 | | 24 | | 26 | | |

¹⁾ This value may only be applied if $l_t \geq 0,5 t_{fix}$

M20 + M24

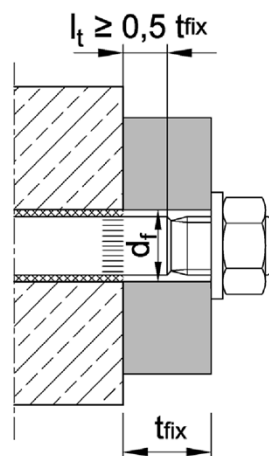

Injection System IM XTREME ETA 1

Performance

Characteristic values for shear load, AX XTREME ETA 1 M16 – M24, static and quasi-static action

Annex C5

**Table C6: Characteristic values for seismic action,
AX XTREME ETA 1 M10 – M12, performance category C1 and C2**

| Anchor size | | AX XTREME ETA 1 | 60 M10 | 75 M10 | 75 M12 | 70 M12 | 80 M12 | 95 M12 | 100 M12 | 110 M12 | 125 M12 | |
|--|--|--------------------------------|----------------------------|----------------|-----------|-----------|-----------|-----------|------------|------------|------------|------|
| Tension loads | | | | | | | | | | | | |
| Installation factor | | γ_{inst} | [-] | | 1,0 | | | | | | | |
| Steel failure, steel zinc plated, stainless steel A4, HCR | | | | | | | | | | | | |
| Characteristic resistance | | $N_{Rk,s,C1}$ $N_{Rk,s,C2}$ | [kN] | | 25 | 35 | 49 | 54 | 57 | | | |
| Partial factor | | γ_{Ms} | [-] | | 1,5 | | | | | | | |
| Pull-out (concrete C20/25 to C50/60) | | | | | | | | | | | | |
| Characteristic resistance | | $N_{Rk,p,C1}$ | 50°C / 80°C ¹⁾ | | [kN] | | 14,5 | 14,5 | 30,6 | 36,0 | 41,5 | 42,8 |
| | | | 72°C / 120°C ¹⁾ | | [kN] | | 10,9 | 10,9 | 20,0 | 30,0 | | |
| | | $N_{Rk,p,C2}$ | 50°C / 80°C ¹⁾ | | [kN] | | 7,4 | 7,4 | 8,7 | 17,6 | | |
| | | | 72°C / 120°C ¹⁾ | | [kN] | | 5,1 | 5,1 | 6,5 | 12,3 | | |
| Shear loads | | | | | | | | | | | | |
| Steel failure <u>without</u> lever arm, steel zinc plated | | | | | | | | | | | | |
| Characteristic resistance | | $V_{Rk,s,C1}$ | [kN] | | 11,8 | 27,2 | | | | | | |
| | | $V_{Rk,s,C2}$ | [kN] | | 12,6 | 27,2 | | | | | | |
| Partial factor | | γ_{Ms} | [-] | | 1,25 | | | | | | | |
| Steel failure <u>without</u> lever arm, stainless steel A4, HCR | | | | | | | | | | | | |
| Characteristic resistance | | $V_{Rk,s,C1}$ | [kN] | | 12,9 | 27,2 | | | | | | |
| | | $V_{Rk,s,C2}$ | [kN] | | 13,8 | 27,2 | | | | | | |
| Partial factor | | γ_{Ms} | [-] | | 1,25 | | | | | | | |
| Factor for anchorages with | | filled annular gap | | α_{gap} | [-] | | 1,0 | | | | | |
| | | unfilled annular gap | | α_{gap} | [-] | | 0,5 | | | | | |

¹⁾ Maximum long-term temperature / Maximum short-term temperature

Injection System IM XTREME ETA 1

Performance

Characteristic values for **seismic action, AX XTREME ETA 1 M10 – M12,**
performance category **C1 and C2**

Annex C6

Table C7: Characteristic values for seismic action, AX XTREME ETA 1 M16 – M24, performance category C1 and C2

| Anchor size | AX XTREME ETA 1 | 90 M16 | 105 M16 | 125 M16 | 145 M16 | 160 M16 | 115 M20 | 170 M20 (LG) | 190 M20 (LG) | 170 M24 (LG) | 200 M24 (LG) | 225 M24 (LG) |
|--|--------------------------------|----------------------------|---------|---------|---------|---------|---------|-------------------------------|--------------------------------|--------------|--------------|--------------|
| Tension loads | | | | | | | | | | | | |
| Installation factor | γ_{inst} | [-] | | 1,0 | | | | | | | | |
| Steel failure, steel zinc plated | | | | | | | | | | | | |
| Characteristic resistance | $N_{Rk,s,C1}$ $N_{Rk,s,C2}$ | [kN] | 88 | 95 | 111 | 97 | 96 | 188 | 222 | | | |
| Steel failure, stainless steel A4, HCR | | | | | | | | | | | | |
| Characteristic resistance | $N_{Rk,s,C1}$ $N_{Rk,s,C2}$ | [kN] | 88 | 95 | 111 | 97 | 114 | 165 | 194 | | | |
| Partial factor | γ_{Ms} | [-] | | 1,5 | | | 1,68 | 1,5 | 1,5 | | | |
| Pull-out (concrete C20/25 to C50/60) | | | | | | | | | | | | |
| Characteristic resistance | $N_{Rk,p,C1}$ | 50°C / 80°C ¹⁾ | [kN] | 30,7 | 38,7 | 43,7 | | 44,4 | 88,2 | 90,7 | | |
| | | 72°C / 120°C ¹⁾ | [kN] | 25,0 | 30,0 | 38,5 | | 29,4 | 55,8 | 59,3 | | |
| | $N_{Rk,p,C2}$ | 50°C / 80°C ¹⁾ | [kN] | 16,3 | 22,1 | 26,1 | | 30,9 | 59,7 | 59,7 | | |
| | | 72°C / 120°C ¹⁾ | [kN] | 10,5 | 14,4 | 19,5 | | 16,2 | 44,4 | 44,4 | | |
| Shear loads | | | | | | | | | | | | |
| Steel failure <u>without</u> lever arm, steel zinc plated | | | | | | | | | | | | |
| Characteristic resistance | $V_{Rk,s,C1}$ | [kN] | 39,1 | | | | 39,1 | 82,3 | 107 | | | |
| | $V_{Rk,s,C2}$ | [kN] | 50,4 | | | | 51 | 108,8 ¹⁾ (71,5) | 154,9 ¹⁾ (122,7) | | | |
| Partial factor | γ_{Ms} | [-] | | 1,25 | | | 1,4 | 1,25 | 1,25 | | | |
| Steel failure <u>without</u> lever arm, stainless steel A4, HCR | | | | | | | | | | | | |
| Characteristic resistance | $V_{Rk,s,C1}$ | [kN] | 39,1 | | | | 39,1 | 72,2 | 93 | | | |
| | $V_{Rk,s,C2}$ | [kN] | 50,4 | | | | 62,6 | 95,6 ¹⁾ (62,8) | 135,7 ¹⁾ (107) | | | |
| Partial factor | γ_{Ms} | [-] | | 1,25 | | | 1,4 | 1,25 | 1,25 | | | |
| Factor for anchorages with | filled annular gap | α_{gap} | [-] | | 1,0 | | | | | | | |
| | unfilled annular gap | α_{gap} | [-] | | 0,5 | | | | | | | |

¹⁾ This value may only be applied if $l_t \geq 0,5 t_{fix}$, (see Annex C4)

Injection System IM XTREME ETA 1

Performance

Characteristic values for seismic action, AX XTREME ETA 1 M16 – M24, performance category C1 and C2

Annex C7

Table C8: Displacements under tension loads, AX XTREME ETA 1 M8 – M12

| Anchor size | | AX XTREME ETA 1 | 40 M8 | 50 M8 | 60 M10 | 75 M10 | 75 M12 | 70 M12 | 80 M12 | 95 M12 | 100 M12 | 110 M12 | 125 M12 |
|---|----------------------|-----------------|-------------------------|----------|-----------|-----------|-----------|-----------|-----------|-----------|------------|------------|------------|
| Tension load in cracked concrete | N | [kN] | 4,3 | 6,1 | 8,0 | 11,1 | 11,1 | 10,0 | 12,3 | 15,9 | 17,1 | 19,8 | 24,0 |
| Displacement | δ_{N0} | [mm] | 0,5 | | 0,5 | 0,6 | 0,6 | | | | 0,7 | | |
| | $\delta_{N\infty}$ | [mm] | 1,3 | | | | | | | | | | |
| Tension load in uncracked concrete | N | [kN] | 4,3 | 8,5 | 11,1 | 15,6 | 15,6 | 14,1 | 17,2 | 19,0 | 24,0 | 23,8 | 23,8 |
| Displacement | δ_{N0} | [mm] | 0,2 | 0,4 | 0,4 | | 0,4 | | | | 0,6 | | |
| | $\delta_{N\infty}$ | [mm] | 1,3 | | | | | | | | | | |
| Displacements under seismic tension loads C2 | | | | | | | | | | | | | |
| Displacements for DLS | $\delta_{N,C2(DLS)}$ | [mm] | No performance assessed | | 1,0 | 1,0 | | 1,3 | | 1,1 | | | |
| Displacements for ULS | $\delta_{N,C2(ULS)}$ | [mm] | No performance assessed | | 3,0 | 3,0 | | 3,9 | | 3,0 | | | |

Table C9: Displacements under tension loads, AX XTREME ETA 1 M16 – M24

| Anchor size | | AX XTREME ETA 1 | 90 M16 | 105 M16 | 125 M16 | 145 M16 | 160 M16 | 115 M20 | 170 M20 (LG) | 190 M20 (LG) | 170 M24 (LG) | 200 M24 (LG) | 225 M24 (LG) |
|---|----------------------|-----------------|-----------|------------|------------|------------|------------|------------|--------------------|--------------------|--------------------|--------------------|--------------------|
| Tension load in cracked concrete | N | [kN] | 14,6 | 18,4 | 24,0 | 30,0 | 34,7 | 21,1 | 38,0 | 44,9 | 38,0 | 48,5 | 57,9 |
| Displacement | δ_{N0} | [mm] | 0,7 | | 0,8 | 1,2 | 0,7 | 0,8 | | 0,8 | 0,9 | | |
| | $\delta_{N\infty}$ | [mm] | 1,3 | | | 1,6 | 1,1 | 1,3 | | 1,3 | | | |
| Tension load in uncracked concrete | N | [kN] | 20,5 | 25,9 | 33,0 | 35,7 | 48,1 | 29,6 | 53,3 | 63,0 | 53,3 | 67,9 | 81,1 |
| Displacement | δ_{N0} | [mm] | 0,6 | | | 0,8 | 0,5 | 0,6 | | 0,6 | | | |
| | $\delta_{N\infty}$ | [mm] | 1,3 | | | 1,6 | 1,1 | 1,3 | | 1,3 | | | |
| Displacements under seismic tension loads C2 | | | | | | | | | | | | | |
| Displacements for DLS | $\delta_{N,C2(DLS)}$ | [mm] | 1,6 | | 1,5 | | 1,7 | 1,9 | | 1,9 | | | |
| Displacements for ULS | $\delta_{N,C2(ULS)}$ | [mm] | 3,7 | | 4,4 | | 4,0 | 4,5 | | 4,5 | | | |

Injection System IM XTREME ETA 1

Performance
Displacements under tension loads, AX XTREME ETA 1

Annex C8

Table C10: Displacements under shear loads AX XTREME ETA 1 M8 – M12

| Anchor size | | AX XTREME ETA 1 | 40 M8 | 50 M8 | 60 M10 | 75 M10 | 75 M12 | 70 M12 | 80 M12 | 95 M12 | 100 M12 | 110 M12 | 125 M12 |
|---|----------------------|-----------------|-------------------------------|----------|-----------|-----------|-----------|-----------|-----------|-----------|------------|------------|------------|
| Shear load | V | [kN] | 8,3 | | 13,3 | | 19,3 | | | | | | |
| Displacements | δ_{V0} | [mm] | 2,4 | 2,5 | 2,9 | | 3,3 | | | | | | |
| | $\delta_{V\infty}$ | [mm] | 3,6 | 3,8 | 4,4 | | 5,0 | | | | | | |
| Displacements under seismic shear loads C2 | | | | | | | | | | | | | |
| Displacements for DLS | $\delta_{V,C2(DLS)}$ | [mm] | No performance assessed | | 2,1 | | 2,5 | | | | | | |
| Displacements for ULS | $\delta_{V,C2(ULS)}$ | [mm] | | | 3,7 | | 5,1 | | | | | | |

Table C11: Displacements under shear loads AX XTREME ETA 1 M16 – M24

| Anchor size | | AX XTREME ETA 1 | 90 M16 | 105 M16 | 125 M16 | 145 M16 | 160 M16 | 115 M20 | 170 M20 (LG) | 190 M20 (LG) | 170 M24 (LG) | 200 M24 (LG) | 225 M24 (LG) |
|---|----------------------|-----------------|-----------|------------|------------|------------|------------|--------------|--------------------|--------------------|--------------------|--------------------|--------------------|
| Shear load | V | [kN] | 36 | | | | 44 | 75 (49) | 89 (71) | | | | |
| Displacements | δ_{V0} | [mm] | 3,8 | | | | 3,0 | 4,3 (3,0) | 4,6 (3,5) | | | | |
| | $\delta_{V\infty}$ | [mm] | 5,7 | | | | 4,5 | 6,5 (4,5) | 6,9 (5,3) | | | | |
| Displacements under seismic shear loads C2 | | | | | | | | | | | | | |
| Displacements for DLS | $\delta_{V,C2(DLS)}$ | [mm] | 2,9 | | | | 3,5 | 3,7 | | | | | |
| Displacements for ULS | $\delta_{V,C2(ULS)}$ | [mm] | 6,8 | | | | 9,3 | 9,3 | | | | | |

Injection System IM XTREME ETA 1

Performance
Displacements under shear loads, AX XTREME ETA 1

Annex C9

Table C12: Characteristic values for tension load, AX-I XTREME ETA 1

| Anchor size | | AX-I XTREME ETA 1 | 40 M6 | 50 M6 | 60 M8 | 75 M8 | 70 M10 | 80 M10 | 90 M12 | 105 M12 | 125 M12 | 115 M16 | 170 M16 | 170 M20 | |
|---|----------------------------|-----------------------|--|--------------|--------------|--------------|--------------|------------|--------------|--------------|------------|--------------|--------------|--------------|------|
| Installation factor | | γ_{inst} [-] | 1,0 | | | | | | | | | | | | |
| Steel failure | | | | | | | | | | | | | | | |
| Characteristic resistance $N_{Rk,s}$ | Steel, zinc plated | [kN] | 15 | 16 | 19 | 29 | 35 | | 67 | | | 52 | 125 | 108 | |
| | A4, HCR | [kN] | 11 | | 19 | 21 | 33 | | 47 | | | 65 | 88 | 94 | |
| Partial factor | | γ_{Ms} [-] | 1,5 | | | | | | | | | | | | |
| Pull-out | | | | | | | | | | | | | | | |
| Characteristic resistance (concrete C20/25) | | | | | | | | | | | | | | | |
| uncracked concrete | 50°C / 80°C ¹⁾ | $N_{Rk,p}$ | [kN] | 9 | 17,4 | 22,9 | 32 | 28,8 | 35,2 | 42 | 52,9 | 68,8 | 60,7 | 109 | 109 |
| | 72°C / 120°C ¹⁾ | | [kN] | 6 | 9 | 16 | 16 | 16 | 25 | 25 | 35 | 50 | 40 | 75 | 95 |
| cracked concrete | 50°C / 80°C ¹⁾ | $N_{Rk,p}$ | [kN] | 8,7 | 12,2 | 16 | 22,4 | 20,2 | 24,6 | 29,4 | 37,1 | 48,1 | 42,5 | 76,3 | 76,3 |
| | 72°C / 120°C ¹⁾ | | [kN] | 5 | 7,5 | 12 | 12 | 16 | 20 | 20 | 30 | 50 | 30 | 60 | 75 |
| Splitting | | | | | | | | | | | | | | | |
| Splitting for standard thickness of concrete | | | | | | | | | | | | | | | |
| Standard thickness of concrete | | $h_{min,1} \geq$ [mm] | 100 | 120 | 150 | 140 | 160 | 180 | 200 | 250 | 230 | 340 | 340 | | |
| Case 1 | | | | | | | | | | | | | | | |
| Characteristic resistance (concrete C20/25) | | $N^0_{Rk,sp}$ [kN] | 7,5 | 9 | 16 | 20 | 20 | 35,2 | 40 | 50 | 50 | 60,7 | 109 | 109 | |
| Case 2 | | | | | | | | | | | | | | | |
| Characteristic edge distance | | $c_{cr,sp}$ [mm] | 3 h_{ef} | 2,5 h_{ef} | 3,5 h_{ef} | 2,5 h_{ef} | 1,5 h_{ef} | 2 h_{ef} | | | | 1,5 h_{ef} | 1,5 h_{ef} | | |
| Splitting for minimum thickness of concrete | | | | | | | | | | | | | | | |
| Minimum thickness of concrete | | $h_{min,2} \geq$ [mm] | 80 | 100 | 110 | 110 | 130 | 150 | 160 | 160 | 220 | 220 | | | |
| Case 1 | | | | | | | | | | | | | | | |
| Characteristic resistance (concrete C20/25) | | $N^0_{Rk,sp}$ [kN] | 7,5 | 2) | 16 | 20 | 25 | 35 | 50 | 40 | 2) | 75 | 109 | | |
| Case 2 | | | | | | | | | | | | | | | |
| Characteristic edge distance | | $c_{cr,sp}$ [mm] | 3 h_{ef} | 3,5 h_{ef} | 3 h_{ef} | 3,5 h_{ef} | 3,5 h_{ef} | 3 h_{ef} | 2,5 h_{ef} | 2,5 h_{ef} | 3 h_{ef} | 2,5 h_{ef} | 2,6 h_{ef} | 2,6 h_{ef} | |
| Increasing factor for $N_{Rk,p} = \psi_c \cdot N_{Rk,p} (C20/25)$ and $N^0_{Rk,sp} = \psi_c \cdot N^0_{Rk,sp} (C20/25)$ ³⁾ | | ψ_c [-] | $\left(\frac{f_{ck}}{20}\right)^{0,5} \leq 1,58$ | | | | | | | | | | | | |
| Concrete cone failure | | | | | | | | | | | | | | | |
| Effective anchorage depth | | h_{ef} [mm] | 40 | 50 | 60 | 75 | 70 | 80 | 90 | 105 | 125 | 115 | 170 | 170 | |

1) Maximum long-term temperature / Maximum short-term temperature

2) No performance assessed

3) Increasing factor for $N^0_{Rk,sp}$ only for Case 1

Injection System IM XTREME ETA 1

Performance

Characteristic values for tension loads, AX-I XTREME ETA 1

Annex C10

Table C13: Characteristic values for shear load, AX-I XTREME ETA 1

| Anchor size | AX-I XTREME ETA 1 | 40 M6 | 50 M6 | 60 M8 | 75 M8 | 70 M10 | 80 M10 | 90 M12 | 105 M12 | 125 M12 | 115 M16 | 170 M16 | 170 M20 |
|--|---------------------|-------|-------|-------|-------|--------|--------|--------|---------|---------|---------|---------|---------|
| Installation factor | γ_{inst} [-] | 1,0 | | | | | | | | | | | |
| Steel failure without lever arm | | | | | | | | | | | | | |
| Characteristic resistance $V_{Rk,s}^0$ | Steel, zinc plated | [kN] | 8,0 | 9,5 | 15 | 18 | | 34 | | 26 | 63 | 54 | |
| | A4, HCR | [kN] | 5,5 | 9,5 | 10 | 16 | | 24 | | 32 | 44 | 47 | |
| Partial factor | γ_{Ms} [-] | 1,25 | | | | | | | | | | | |
| Ductility factor | k_7 [-] | 1,0 | | | | | | | | | | | |
| Steel failure with lever arm | | | | | | | | | | | | | |
| Characteristic bending resistance $M_{Rk,s}^0$ | Steel, zinc plated | [kN] | 12 | 30 | 60 | 105 | 212 | 266 | 519 | | | | |
| | A4, HCR | [kN] | 8,5 | 21 | 42 | 74 | 187 | 187 | 365 | | | | |
| Partial factor | γ_{Ms} [-] | 1,25 | | | | | | | | | | | |
| Concrete pry-out failure | | | | | | | | | | | | | |
| Pry-out factor | k_8 [-] | 2,0 | | | | | | | | | | | |
| Concrete edge failure | | | | | | | | | | | | | |
| Effective length of anchor in shear load | l_f [mm] | 40 | 50 | 60 | 75 | 70 | 80 | 90 | 105 | 125 | 115 | 170 | 170 |
| Outside diameter of anchor | d_{nom} [mm] | 10 | 12 | 14 | 18 | 22 | 24 | 26 | | | | | |

Table C14: Displacements under tension loads, AX-I XTREME ETA 1

| Anchor size | AX-I XTREME ETA 1 | 40 M6 | 50 M6 | 60 M8 | 75 M8 | 70 M10 | 80 M10 | 90 M12 | 105 M12 | 125 M12 | 115 M16 | 170 M16 | 170 M20 |
|------------------------------------|-------------------------|-------|-------|-------|-------|--------|--------|--------|---------|---------|---------|---------|---------|
| Tension load in cracked concrete | N [kN] | 4,3 | 6,1 | 8,0 | 11,1 | 10,0 | 12,3 | 14,6 | 18,4 | 24,0 | 21,1 | 38,0 | 38,0 |
| Displacement | δ_{N0} [mm] | 0,5 | 0,5 | 0,6 | 0,6 | 0,7 | 0,7 | 0,7 | 0,7 | 0,7 | 0,7 | 0,8 | 0,8 |
| | $\delta_{N\infty}$ [mm] | 1,3 | | | | | | | | | | 1,1 | 1,3 |
| Tension load in uncracked concrete | N [kN] | 4,3 | 8,5 | 11,1 | 15,6 | 14,1 | 17,2 | 20,5 | 25,9 | 33,0 | 29,6 | 53,3 | 53,3 |
| Displacement | δ_{N0} [mm] | 0,2 | 0,4 | 0,4 | 0,4 | 0,4 | 0,4 | 0,6 | 0,6 | 0,6 | 0,5 | 0,6 | 0,6 |
| | $\delta_{N\infty}$ [mm] | 1,3 | | | | | | | | | | 1,1 | 1,3 |

Table C15: Displacements under shear loads, AX-I XTREME ETA 1

| Anchor size | AX-I XTREME ETA 1 | 40 M6 | 50 M6 | 60 M8 | 75 M8 | 70 M10 | 80 M10 | 90 M12 | 105 M12 | 125 M12 | 115 M16 | 170 M16 | 170 M20 |
|--------------------------------|-------------------------|-------|-------|-------|-------|--------|--------|--------|---------|---------|---------|---------|---------|
| Shear load, Steel, zinc plated | V [kN] | 4,6 | 5,4 | 8,4 | 10,1 | 19,3 | 14,8 | 35,8 | 30,7 | | | | |
| | δ_{V0} [mm] | 0,4 | 0,5 | 0,4 | 0,5 | 1,2 | 0,8 | 1,9 | 1,2 | | | | |
| Displacement | $\delta_{V\infty}$ [mm] | 0,7 | 0,8 | 0,7 | 0,8 | 1,9 | 1,2 | 2,8 | 1,9 | | | | |
| | V [kN] | 3,2 | 5,4 | 5,9 | 9,3 | 13,5 | 18,5 | 25,2 | 26,9 | | | | |
| Displacement | δ_{V0} [mm] | 0,3 | 0,5 | 0,3 | 0,5 | 0,9 | 1,0 | 1,4 | 1,1 | | | | |
| | $\delta_{V\infty}$ [mm] | 0,4 | 0,7 | 0,5 | 0,7 | 1,4 | 1,5 | 2,1 | 1,6 | | | | |

Injection System IM XTREME ETA 1

Performance
Characteristic values for shear load AX-I XTREME ETA 1,
Displacements AX-I XTREME ETA 1

Annex C11