

Public-law institution jointly founded by the federal states and the Federation

European Technical Assessment Body
for construction products



European Technical Assessment

ETA-15/0599
of 12 February 2026

English translation prepared by DIBt - Original version in German language

General Part

Technical Assessment Body issuing the European Technical Assessment:

Deutsches Institut für Bautechnik

Trade name of the construction product

Schüco AWS 114 SG and Schüco AWS 114 SG.SI

Product family to which the construction product belongs

Structural Sealant Glazing Opening Units for Facade Constructions

Manufacturer

SCHÜCO International KG
Karolinenstraße 1-15
33609 Bielefeld
DEUTSCHLAND

Manufacturing plant

SCHÜCO International KG
Karolinenstraße 1-15
33609 Bielefeld
DEUTSCHLAND

This European Technical Assessment contains

23 pages including 12 annexes (Annexes A to C and Annexes 1 – 9) which form an integral part of this assessment.

This European Technical Assessment is issued in accordance with Article 95(4) of Regulation (EU) No 2024/3110, on the basis of

EAD 090010-00-0404

This version replaces

ETA-15/0599 issued on 19 May 2016

The European Technical Assessment is issued by the Technical Assessment Body in its official language. Translations of this European Technical Assessment in other languages shall fully correspond to the original issued document and shall be identified as such.

Communication of this European Technical Assessment, including transmission by electronic means, shall be in full. However, partial reproduction may only be made with the written consent of the issuing Technical Assessment Body. Any partial reproduction shall be identified as such.

This European Technical Assessment may be withdrawn by the issuing Technical Assessment Body, in particular pursuant to information by the Commission in accordance with Article 36(3) of Regulation (EU) No 2024/3110.

Specific part

1 Technical description of the product

The subjects of this European Technical Assessment (ETA) are the opening units of the profile systems Schüco AWS 114 SG and AWS 114 SG.SI (Annexes 1 to 6). The opening units are insulating glass units consisting of two or three glass panes. They are manufactured as stepped insulating glass in which the panes are secured by bonding. The opening units are designed as projected top hung windows or parallel opening windows. Depending on their size, they are either manually or electrically opened and closed in accordance with the specifications provided by SCHÜCO International KG.

The outer pane is factory-bonded in a load-bearing manner to the outer shell of the casement which is connected via thermal barriers to the inner shell of the casement. Glass supports are used to bear the weight of the panes. If the bond fails, mechanical retaining systems are provided. The depth of the thermal barriers varies depending on the respective glass composition. Metal corner connector profiles are pushed into the corners of the perimeter casements.

The allowable opening unit size depends on the location-specific actions to be taken into consideration that means the results of the required structural analysis.

The system design is illustrated in Annex 1 by means of a two-pane projected top hung window as an example.

2 Specification of the intended use in accordance with the applicable European Assessment Document

The opening units of the Schüco AWS 114 SG and AWS 114 SG.SI profile systems are installed vertically.

The bonded structures correspond to Type I or Type II in accordance with EAD 090010-00-0404¹. For Type I mechanical support of the weight of the glass and additionally mechanical retaining devices for absorbing the wind loads in the event that the bond fails are required. For Type II only mechanical supports, but no mechanical retaining devices, are required.

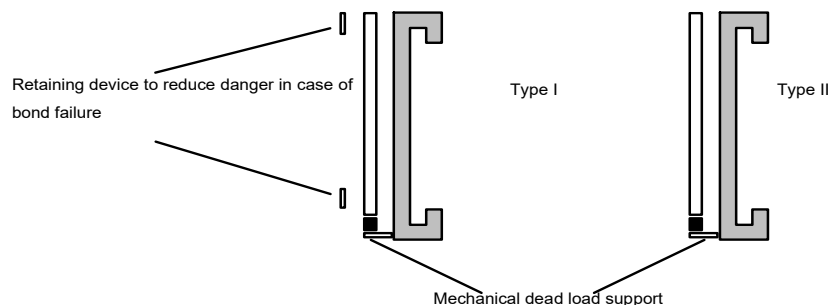

The opening units are not designed for stiffening other components.

¹ EAD Nr. 090010-00-0404:2018-09 Bonded glazing kits and bonding sealants

The performance characteristics specified in Section 3 can only be assumed if structural calculations in accordance with the specifications given in Section 3.5 have been carried out for the bonded sealant glazing opening units in the respective application case.

The following service classes are distinguished:

- 1a) Use of monolithic panes for the outer pane of the insulating glass (e.g. in Germany for an installation height of more than 4 m) made from heat soaked thermally toughened soda lime silicate safety glass in accordance with EN 14179-1²
- 1b) Use of monolithic panes for the outer pane of the insulating glass (e.g. in Germany for an installation height of less than 4 m) made from thermally toughened soda lime silicate safety glass in accordance with EN 12150-1³ and EN 12150-2⁴.
- 2a) Use of laminated safety glass in accordance with EN 14449⁵ with PVB interlayer in consideration of the tensile strength of > 20 N/mm² and elongation at fracture of > 250%; a compound effect is not taken into consideration when verifying the panes
- 2b) Use of laminated safety glass in accordance with EN 14449 with consideration of a compound effect for G = 0.4 N/mm²
- 3a) Restricted use in accordance with local conditions regarding the reaction to fire
- 3b) There are no use restrictions regarding the reaction to fire

The test and assessment methods on which this European Technical Assessment is based lead to the assumption of a working life of the opening unit of at least 25 years. The indications given on the working life cannot be interpreted as a guarantee given by the manufacturer, but are to be regarded only as a means for choosing the right products in relation to the expected economically reasonable working life of the works.

3 Performance of the product and references to the methods used for its assessment

3.1 Safety in case of fire (BWR 2)

Essential characteristic	Assessment method	Performance
Reaction to fire of glass panes and metal parts in accordance with Commission Decision 96/603/EC	EAD, 2.2.2	Class A1
Reaction to fire of adhesives and seals		Class E

3.2 Hygiene, health and the environment (BWR 3)

Essential characteristic	Assessment method	Performance
Contents and/or release of dangerous substances	EAD, 2.2.7	The chemical composition of the structural sealant has to be in compliance with the composition deposited at the Technical Assessment Body (DIBt).

² EN 14179-1:2016

Glass in building – Heat soaked thermally toughened soda lime silicate safety glass – Part 1: Definition and description;

³ EN 12150-1:2000

Glass in building – Thermally toughened soda lime silicate safety glass – Part 1: Definition and description;

⁴ EN 12150-2:2004

Glass in building – Thermally toughened soda lime silicate safety glass – Part 2: Evaluation of conformity/Product standard

⁵ EN 14449:2005/AC:2005

Glass in building – Laminated glass and laminated safety glass – Evaluation of conformity/Product standard

Within the scope of this European Technical Assessment there may be other requirements applicable to the product (e.g. due to national laws, regulations and administrative provisions). These requirements need also to be complied with if applicable.

3.3 Safety and accessibility in use (BWR 4)

Essential characteristic	Assessment method	Performance
Glass panes and adhesives: Characteristic bending strength Heat-soaking Laminated safety glass properties Suitable adhesives and glass surfaces	EAD, 2.2.14 und 2.2.15 Glass surfaces: EAD 3.4.3	See Annex A
Silicone adhesives: <ul style="list-style-type: none"> • DC 993 in accordance with ETA-01/0005, • Sikasil SG 500 in accordance with ETA-03/0038, • KÖDIGLAZE S in accordance with ETA-08/0286 for bonding with the following substrates: Aluminium profile EN AW 6060 in accordance with EN 573-3 ⁶ , state T66 in accordance with EN 755-2 ⁷ : <ul style="list-style-type: none"> • Colours E6-C0 to E6-C35, anodized by Königsdorf company, Wolfhagen*; • colours E6-C0 to E6-C35, anodized by HD Wahl company, Jettingen - Scheppach*; • Colour E6-1003 (C05), anodized by ALCAN company, 89600 Saint Florentin, France* 	EAD, 1.1.2, D 3.1.1.4 Annex D D.2 and D.3	Verification of suitability of the anodized aluminium profiles for bonding passed successfully.
Load-bearing capacity of glass supports	EAD, 1.7	See Annex B
Load-bearing capacity of mechanical retaining systems	No specific assessment method in the EAD	See Annex C

* Informations about the anodizing processes are deposited with Deutsches Institut für Bautechnik.

⁶ EN 573-3:2007 Aluminium and aluminium alloys - Chemical composition and form of wrought products – Part 3: Chemical composition and wrought form of products

⁷ EN 755-2:2006 Aluminium and aluminium alloys - Extruded rod/bar, tube and profiles - Part 2: Mechanical properties

Essential characteristic	Assessment method	Performance	
System tests with compositions according to the deposited test reports		Top hung windows AWS 114 SG / AWS 114 SG.SI	Parallel opening windows AWS 114 SG / AWS 114 SG.SI
		1500 mm x 2000 mm 2200 mm x 1400 mm	1200 mm x 2000 mm
Air permeability in accordance with EN 12207 ⁸	EAD, 2.2.8	Class 4	Class 4
Watertightness in accordance with EN 12208 ⁹	EAD, 2.2.9	Class E1200	Class E1200
Capability of resistance to wind load in accordance with EN 12210 ¹⁰	EAD, 2.2.10	Class C5 / B5	Class C5 / B5
Impact resistance in accordance with EN 13049 ¹¹	EAD, 2.2.12	AWS 114 SG.SI 1000 mm x 1000 mm: Class 4	AWS 114 SG.SI 1000 mm x 1000 mm: Class 4

Essential characteristic	Assessment method	Performance		
System tests with compositions according to the deposited test reports		Top hung windows (TipTronic) AWS 114 SG AWS 114 SG.SI	Parallel opening windows (TopTronic) AWS 114 SG AWS 114 SG.SI	Parallel opening windows (TopTronic) AWS 114 SG AWS 114 SG.SI
		2700 mm x 2500 mm	2700 mm x 2500 mm	1560 mm x 1735 mm
Air permeability in accordance with EN 12207	EAD, 2.2.8	Class 4	Class 4	Class 3
Watertightness in accordance with EN 12208	EAD, 2.2.9	Class E1200	Class E1200	Class E1200
Capability of resistance to wind load in accordance with EN 12210	EAD, 2.2.10	Class C5 / B5	Class C5 / B5	Class C5 / B5

⁸ EN 12207:1999 Windows and doors - Air permeability - Classification
⁹ EN 12208:1999 Windows and doors - Watertightness - Classification
¹⁰ EN 12210:2003 Windows and doors - Resistance to wind load - Classification (includes Corrigendum AC:2002)
¹¹ EN 13049:2003 Windows - Soft and heavy body impact - Test method, safety requirements and classification

3.4 Protection against noise (BWR 5)

The sound insulation values given in the following table apply to the given glass composition and an element size of up to 2.70 m². Transfer to larger sizes is possible via correction values in accordance with table 3 in Annex B to EN 14351-1¹².

System	Assessment method	Glass composition	8/16 Ar/4	10/16 Ar/8VSG SI	10 VSG SI/12 Ar/6/12 Ar/8 VSG SI
		Nominal glass thickness	28 mm	34 mm	48 mm
		R _w , glass	37 dB	45 dB	49 dB
		R _w (C, C _{tr}) in dB			
AWS 114 SG.SI without retention frame	EAD, 2.2.18	Joint unsealed	36 (-1;-4)	40 (-2;-4)	41 (0;-2)
		Joint sealed	37 (-1;-5)	43 (-2;-5)	46 (-1;-5)
AWS 114 SG.SI.TT without retention frame		Joint unsealed	36 (-1;-4)	39 (-1;-3)	40 (-1;-2)
		Joint sealed	37 (-1;-5)	42 (-1;-4)	45 (-1;-5)
AWS 114 SG.SI with retention frame		Joint unsealed	37 (-2;-5)	40 (-1;-3)	43 (-2;-4)
		Joint sealed	38 (-2;-6)	43 (-1;-5)	47 (-2;-6)
AWS 114 SG.SI.TT with retention frame		Joint unsealed	36 (-1;-4)	40 (-1;-3)	41 (0;-2)
		Joint sealed	37 (-1;-5)	42 (-1;-4)	45 (-1;-5)

3.5 General aspects

3.5.1 Information pertaining to structural verification of bonded opening units

Verification of durability shall be carried out within the scope of testing of the essential characteristics. The durability can only be guaranteed if the special provisions regarding the intended use in accordance with the following requirements and information are adhered to.

The conditions given in Annex A shall apply to the stepped insulating glass units.

If laminated safety glass is used, a favourably shear transfer between individual panes shall be permitted to be considered when dimensioning the glass panes in accordance with local safety provisions (service class 2a) or 2b) according to section 2 of this ETA).

Further information can be found in Annexes A, B, C and D.

3.5.2 Information pertaining to structural verification of the substructure

The structural analysis shall show that the dead load of the glass and the wind loads can be absorbed by the substructure.

The joint widths shall be adapted to the total deformations with the aim of excluding the possibility of glass-to-glass or glass-to-steel contact.

3.5.3 Information pertaining to production

The opening units may only be manufactured and sealed in factories. The sealing companies are to be adequately trained by SCHÜCO International KG. SCHÜCO International KG maintains a list of authorised sealing companies, which has to be updated continually. This list is to be provided to Deutsches Institut für Bautechnik on request.

¹²

EN 14351-1:2006+A2:2016 Windows and doors - Product standard, performance characteristics - Part 1: Windows and external pedestrian doorsets without resistance to fire and/or smoke leakage characteristics

The bonding surfaces shall be prepared following the adhesive-manufacturing plants' work instructions deposited with Deutsches Institut für Bautechnik. The adhesive joint in the space between the glass and the adjacent profile (adjacent frame element) shall be completely filled over the entire perimeter. The thickness of the silicone bond between the glass pane and the profile shall be no less than 6 mm and the width shall be no less than 12 mm. The exact dimensions shall be verified via calculations.

3.5.4 Information pertaining to installation

The opening units shall be fixed to the supporting structure in accordance with the processing guidelines of SCHÜCO International KG such that no constraints can occur in the elements. Installation shall be carried out exclusively by experts trained for this purpose by SCHÜCO International KG.

4 Assessment and verification of constancy of performance (AVCP) system applied, with reference to its legal base

In accordance with the European assessment document ETAG 002 the legal basis is: 96/582/EC (Official Journal of the EC No. L 254 of 08/10/1996).

The system(s) to be applied is (are):

Product	Intended use	System
Structural sealant glazing kits (SSGKs)	Type II	1
	Type I	2+

5 Technical details necessary for the implementation of the AVCP system, as provided for in the applicable EAD

The technical details necessary for the implementation of the AVCP system are laid down in the control plan deposited with Deutsches Institut für Bautechnik.

Issued in Berlin on 12 February 2026 by Deutsches Institut für Bautechnik

Dipl.- Ing. Andreas Kummerow
Head of Department

beglaubigt:
Schult

Annex A

Glass panes

The selection of the glass products and the ultimate limit state and serviceability limit state calculations shall be carried out in consideration of the relevant actions. Furthermore, the glass products shall be chosen in line with the applicable service classes for use in accordance with Section 2 of this ETA.

The glass panes shall be manufactured in accordance with harmonized European standards, specifying the characteristic bending strength in the declaration of performance.

For use of laminated safety glass the local requirements shall be considered with reference to the service classes given in Section 2 of this ETA.

Adhesives

For the structural bonding between the glass panes and the frame profiles of the opening units Schüco AWS 114 SG and AWS 114 SG.SI the following adhesives apply:

- DC 993 according to ETA-01/0005
- Sikasil SG 500 according to ETA-03/0038
- KÖDIGLAZE S according to ETA-08/0286

For the structural insulating glass edge sealant of the opening units Schüco AWS 114 SG and AWS 114 SG.SI the following adhesives apply:

- DC 3362 according to ETA-03/0003
- Sikasil IG 25 according to ETA-05/0068
- GD 920 according to ETA-08/0004

Adhesion surfaces

1. The specifications of ETA-01/0005, ETA-03/0038 and ETA-08/0286 as well as the following requirements shall apply to the structural sealants between the glass panes and the structural frames of the opening units.

When manufacturing stepped insulating glass with use of adhesive DC 993 in accordance with ETA-01/0005, the bonding surface shall be permitted to be coated with an adhesive layer of thickness 1.5 ± 0.5 mm in accordance with the procedure deposited with Deutsches Institut für Bautechnik prior to the actual bonding. Only the following combinations shall be permitted (glass side – aluminium side):

- DC 993 – DC 993
- DC 3793 – DC 993
- DC 3362 – DC 993

When manufacturing stepped insulating glass with use of adhesive SIKASIL SG 500 in accordance with ETA-03/0038, the bonding surface shall be permitted to be coated with an adhesive layer of thickness 1.5 ± 0.5 mm in accordance with the procedure deposited with Deutsches Institut für Bautechnik prior to the actual bonding. Only the following combinations shall be permitted (glass side – aluminium side):

- SIKASIL SG 500 – SIKASIL SG 500
- SIKASIL IG 25 – SIKASIL SG 500

2. For the structural insulating glass edge seal between the glass panes, use of silicone adhesives as per ETA-01/0005, ETA-03/0038 and ETA-08/0286 as well as silicone adhesives as per ETA-03/0003, ETA-05/0068 and ETA-08/0004 shall be permitted. As a prerequisite, the compatibility of the adhesive with the one used for bonding to the frame profiles shall be verified.

3. The anodized aluminium profiles to which the glass panes are bonded shall comply with section 3.1 of this ETA.

Compatibility

Only the materials listed below shall be permitted to be installed adjacent to the structural sealant; the compatibility of these materials with the adhesives has been verified within the scope of the assessment procedure.

Permissible combinations of structural sealants and adjacent materials													
Manufacturer	Structural sealant	Inner seal / butyl					Spacer tape Cover profile Sealing profile			Glazing support/ setting block			
		BU-S, Kömmerling	Climafill standard, NMC sa	GD 115, Kömmerling	Terostat 969, Fa: H.B. Fuller	Sika Glaze IG-5, SIKA SERVICES	Norton V 2100	Norton V 3100	Vito Glazing mount 400	EPDM DIN 7863, Type C	Silicone, Sico	GLSV, Gluske	polypropylene, Repsol
Dow Corning	DC 993	X	X	X			X	X		X	X	X	X
	DC 3362	X	X		X						X	X	
Sika AG	Sikasil SG 500	X				X	X		X	X	X		X
	Sikasil IG 25	X									X		
Kömmerling	KÖDIGLAZ E S			X			X		X				
	GD 920			X									

Applicable coating/enamelling

Provided that the ETA for the adhesive includes already tested coating for glass the edges to be sealed may be used with this coating.

Consecutively coated glass products are listed that are permitted to be sealed using the DC 993 adhesive from Dow Corning without removal of the coating at the edges.

Manufacturer	Name of the product
Ferro AG, Frankfurt a.M., Germany	Glaskeramische Farbe, Kollektion 34
	Glaskeramische Farbe, Kollektion 140
Glas Trösch AG, Switzerland	SILVERSTAR Sunstop T Silber 20
	SILVERSTAR Sunstop T Silber 20 mit Siebdruck *
	SILVERSTAR Sunstop T Blau 30
	SILVERSTAR Sunstop T Blau 50
Glas Trösch AG, Switzerland	SILVERSTAR Sunstop T Neutral 50
	Stopsol Supersilver klar
	SunGuard Solar Light Blue 52
	SunGuard Solar HP Neutral 41/33
Guardian, Luxemburg	SunGuard Solar HP Neutral 52/41
	SunGuard Solar HP Neutral 61/42
	SunGuard Solar Light Blue 62/52
	SunGuard Solar HP Silver 43/31
	SunGuard Solar HP Royal Blue 38/31
	SunGuard Solar Neutral 67
	SunGuard Solar Silver Grey 32
	SunGuard Solar Silver 20
	SunGuard Solar Royal Blue 20 *
	SunGuard Solar Solar Silver 08
	Saint Gobain Glas, Belgium
Cool-Lite ST 108	
Cool-Lite ST 108	
Cool-Lite ST 108	
Cool-Lite ST 108	
Antelio clear	
Antelio silver	

* these coatings may also be enamelled with Ferro, collection 140

If coated glass not listed in the ETA for the adhesive or in the above table is used it shall be ensured that the structural sealant region at the edges of the panes is uncoated or the coating is first completely mechanically removed from the edges to be sealed. The glass shall not be damaged in the process.

Annex B

Glass supports

Glass supports of 100 mm as specified in Annex 7 support the weight of the Schüco AWS 114 SG and AWS 114 SG.SI opening units. Use of the following articles in the systems of this European Technical Assessment shall be permitted.

Support for	Art. nos	Type of fastener	Glass support material	Setting block**
Schüco AWS 114 SG				
Outer pane; structure without mechanical wind suction retaining devices*	268030 268031 268089 268088	Flat head sheet metal screws ST 3.9-A4-70, length 16 mm Screw joint between casement profile and corner connector profile	Aluminium EN AW 6005A in accordance with DIN EN 573-3	Silicon pad
Inner panes	266673 266674	Suspended in the casement	Aluminium EN AW 6005A in accordance with DIN EN 573-3	Silicon pad
Schüco AWS 114 SG.SI				
Outer pane; Structure without mechanical wind suction retaining devices *	268030 268031 268089 268088	Flat head sheet metal screws ST 3.9-A4-70, length 16 mm Screw joint between thermal barrier and corner connector profile	Aluminium EN AW 6005A in accordance with DIN EN 573-3	Silicon pad
Inner panes	266675 266677 268027	Suspended in the casement	Aluminium EN AW 6005A in accordance with DIN EN 573-3	Silicon pad
* If mechanical wind suction retaining devices are used, the weight of the outer pane is absorbed by the retention frame in accordance with Section 2.1.4.				
** The material properties are deposited with Deutsches Institut für Bautechnik.				

The weight of the outer glass panes in the Schüco AWS 114 SG and AWS 114 SG.SI systems shall be transferred to the casement via the outer glass supports and the corner connector profiles.

The glass supports have plastic or silicone pads with a Shore A hardness of approx. 70 ± 5 in accordance with DIN 53505¹³.

Verifications

The glass supports shall be verified for the dead loads of the opening units applicable in the relevant application case.

The load-bearing capacities determined from tests are listed in the following table. Some of the tests were aborted prior to failure due to excessive deformation. For such cases, the mean of the maximum measured load is given in the table below. In the tests, the load was applied to the centre of gravity of the opening unit. The deformation of the glass support was recorded in each case. Details can be found in the processing guidelines of the approval holder, SCHÜCO International KG. The specifications for service loads and deformation as well as for installation given therein shall be adhered to.

Glass support Art. no	Load-bearing capacity (5% fractile / 75% confidence level; $\gamma_{glob} = \gamma_M \cdot \gamma_F = 1.7$) or maximum measured loads*
266673, 266674, 266675, 266677	1.53 kN
266664, 266665	1.53 kN
266666	1.22 kN
268027	1.22 kN
266442	4.41 kN *
266443	2.20 kN *
268030, 268031, 268088, 268089	0.24 kN

Annex C

Emergency mechanical retaining systems

For use corresponding to type I, the Schüco AWS 114 SG and AWS 114 SG.SI structural sealant glazing opening units shall be designed in accordance with ETAG 002-1 with the retention frames listed below to absorb the dead loads of the outer pane as well as the wind suction loads in the event that the bond fails. Retention frames with art. nos 448320, 448330, 448500 and 448510 for AWS 114 SG and art. nos 448520, 448530, 448540 and 448550 for AWS 114 SG.SI shall be composed of EN AW 6060-T66.

These retention frames shall be screwed on to the frame system along the perimeter with a screw spacing of 250 mm. In the corner regions, the distance between the screws and the corner shall be 50 mm. The retention frames shall be screwed to the corner connector profiles.

The retention frames with art. nos 448320, 448330, 448500, 448510 and 448520, 448530, 448540, 448550 shall be permitted to be loaded with dead loads and wind suction loads. The following values were determined as load-bearing capacities for the specified retention frames within the scope of the assessment procedure.

Load-bearing capacities for loading in dead weight loading direction

Frame system	$\eta \times F_{5\%}$ [kN]
AWS 114 SG	2.79
AWS 114 SG.SI	1.49

Load-bearing capacities for loading in direction of wind suction (negative wind pressure)

Frame system	$\eta \times F_{5\%}$ [kN/m]
AWS 114 SG	8.92
AWS 114 SG.SI	8.80

Both actions shall be considered through a linear interaction.

$$\frac{E_{h,d}}{R_{h,d}} + \frac{E_{v,d}}{R_{v,d}} \leq 1$$

$E_{h,d}$ = Design wind suction load

$R_{h,d}$ = Design resistance to wind suction (negative wind pressure)

$E_{v,d}$ = Design dead load

$R_{v,d}$ = Design resistance to dead load

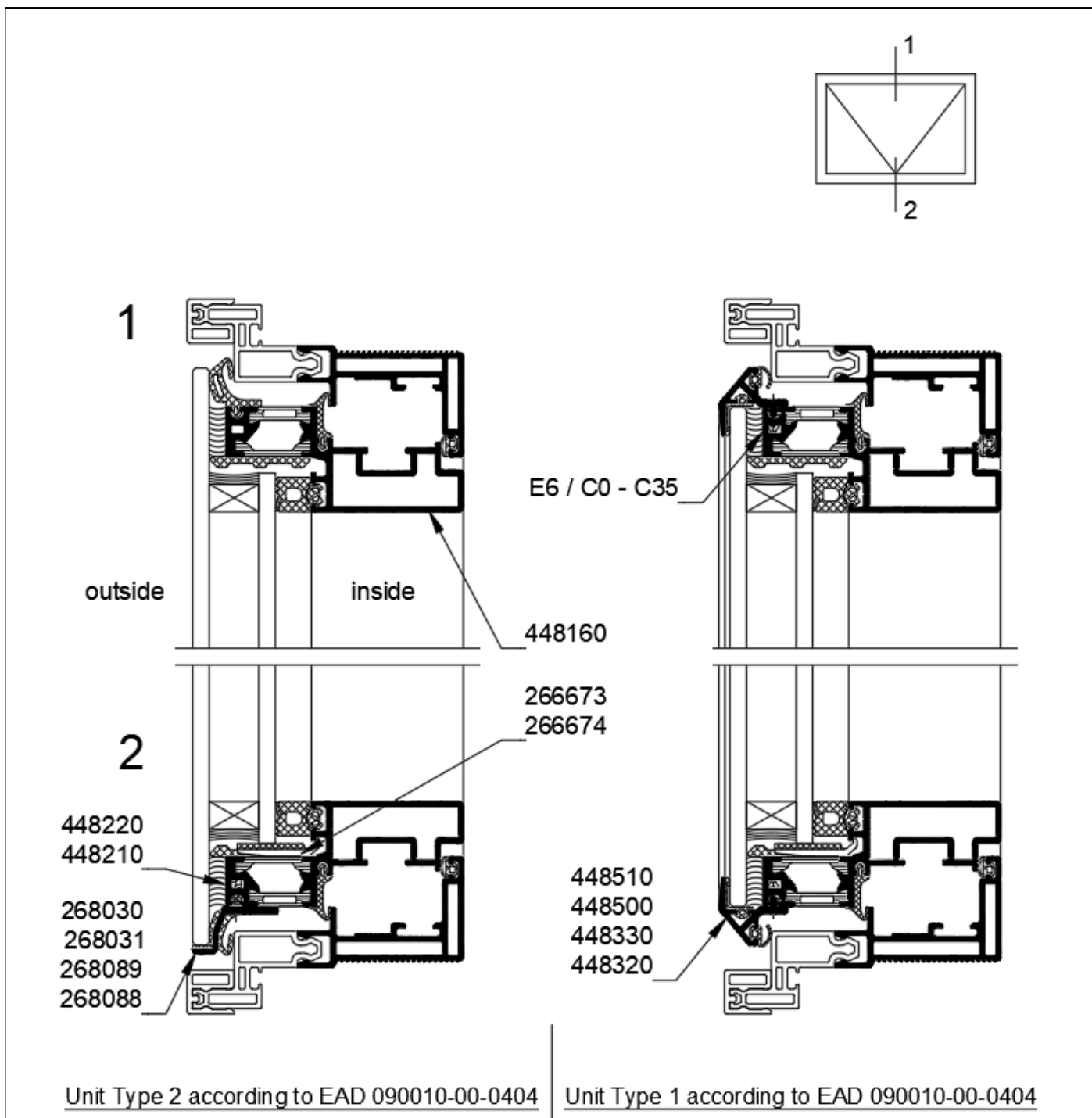

Glass support for insert elements also referred in annex 7

Bonded sealant glazing opening units for facade constructions
Schüco AWS 114 SG und Schüco AWS 114 SG.SI

Projected top hung window Schüco AWS 114 SG with stepped insulating glass

Annex 1

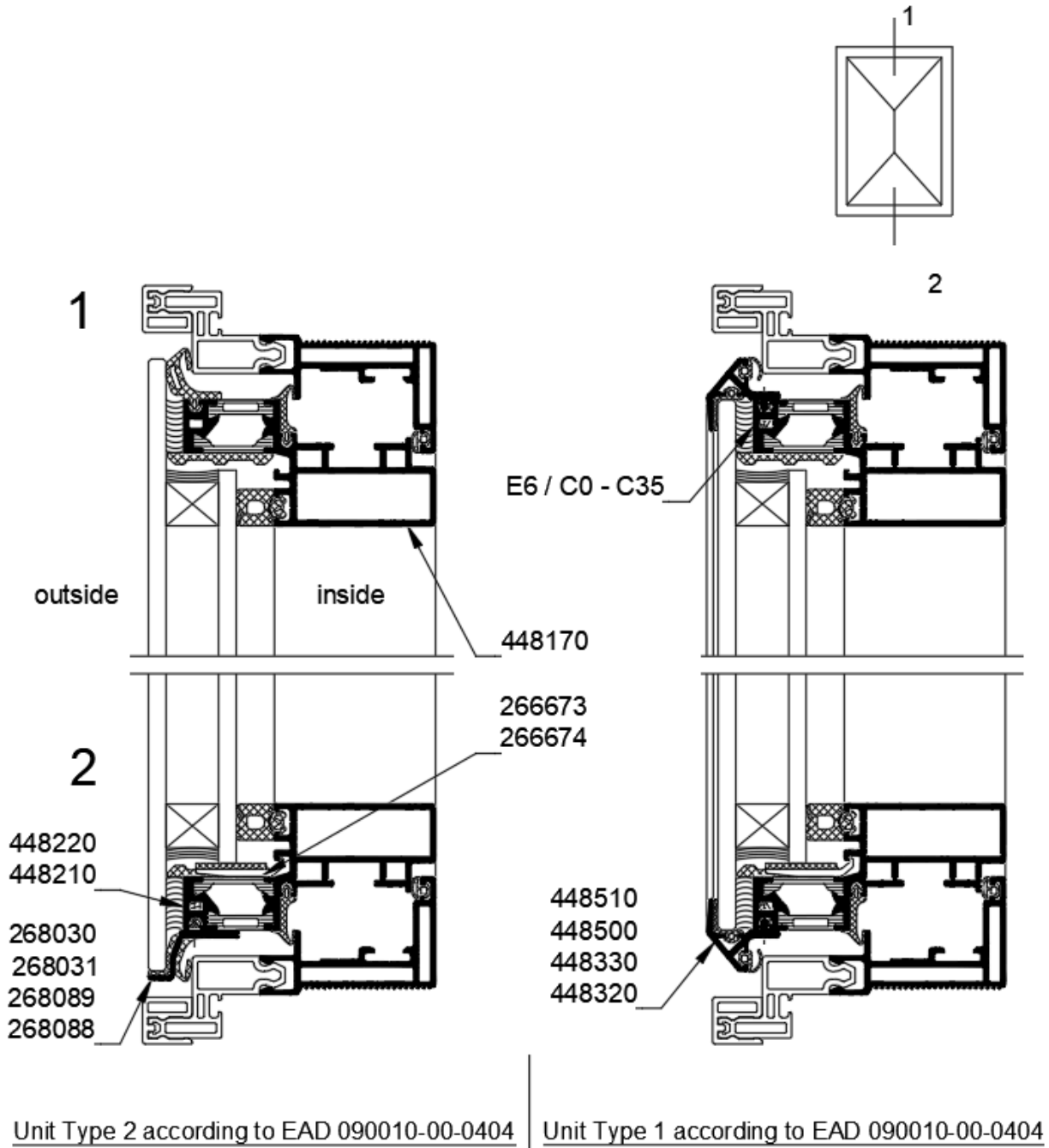

Glass support for insert elements also referred in annex 7

Bonded sealant glazing opening units for facade constructions Schüco AWS 114 SG und Schüco AWS 114 SG.SI	Annex 2
Parallel opening window Schüco AWS 114 SG with stepped insulating glass	

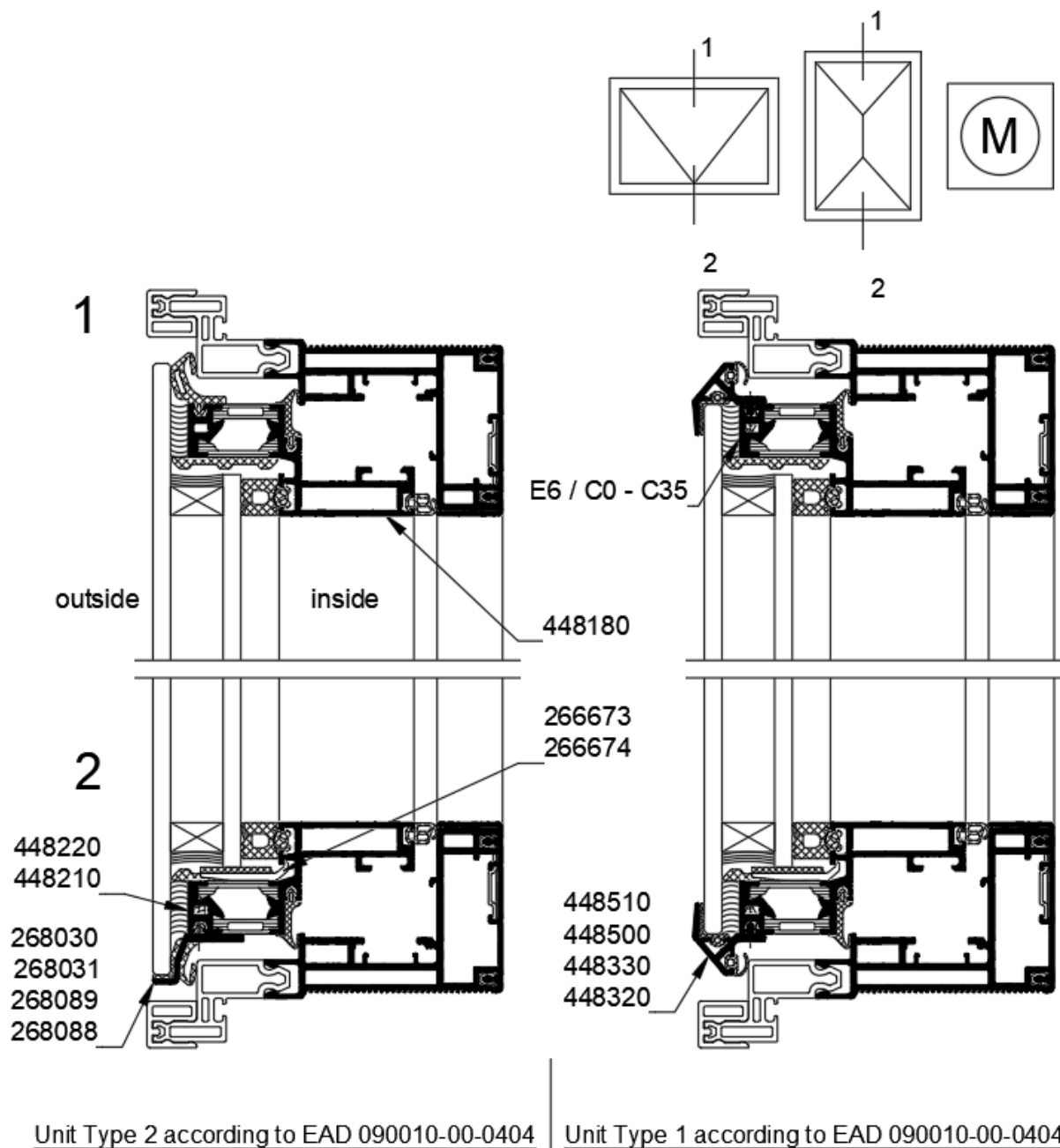

Glass support for insert elements also referred in annex 7

Bonded sealant glazing opening units for facade constructions
Schüco AWS 114 SG und Schüco AWS 114 SG.SI

Opening units with motor drive (TipTronic) Schüco AWS 114 SG with stepped
insulating glass

Annex 3

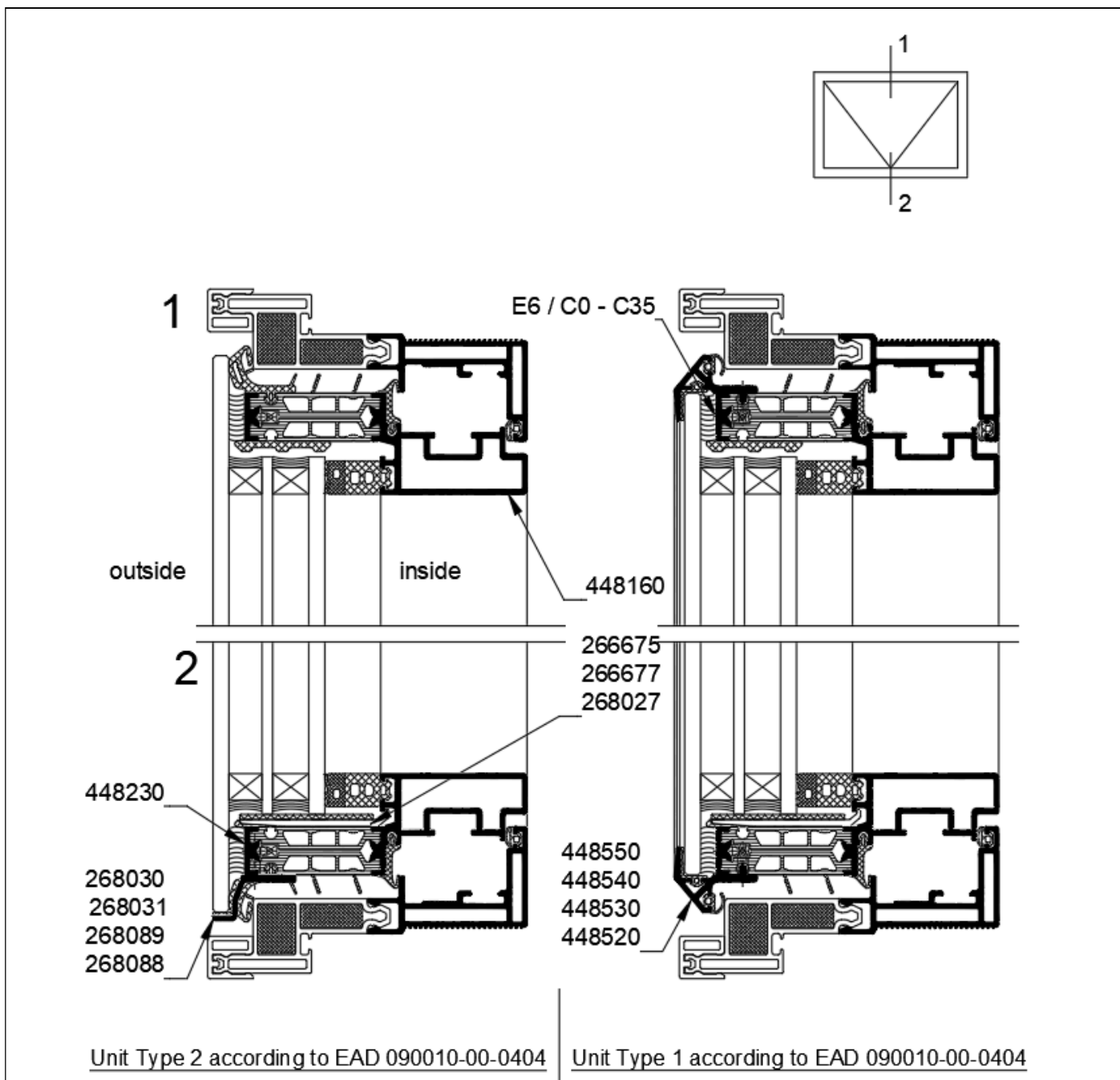

Glass support for insert elements also referred in annex 7

Bonded sealant glazing opening units for facade constructions
Schüco AWS 114 SG und Schüco AWS 114 SG.SI

Projected top hung window Schüco AWS 114 SG.SI with stepped insulating glass

Annex 4

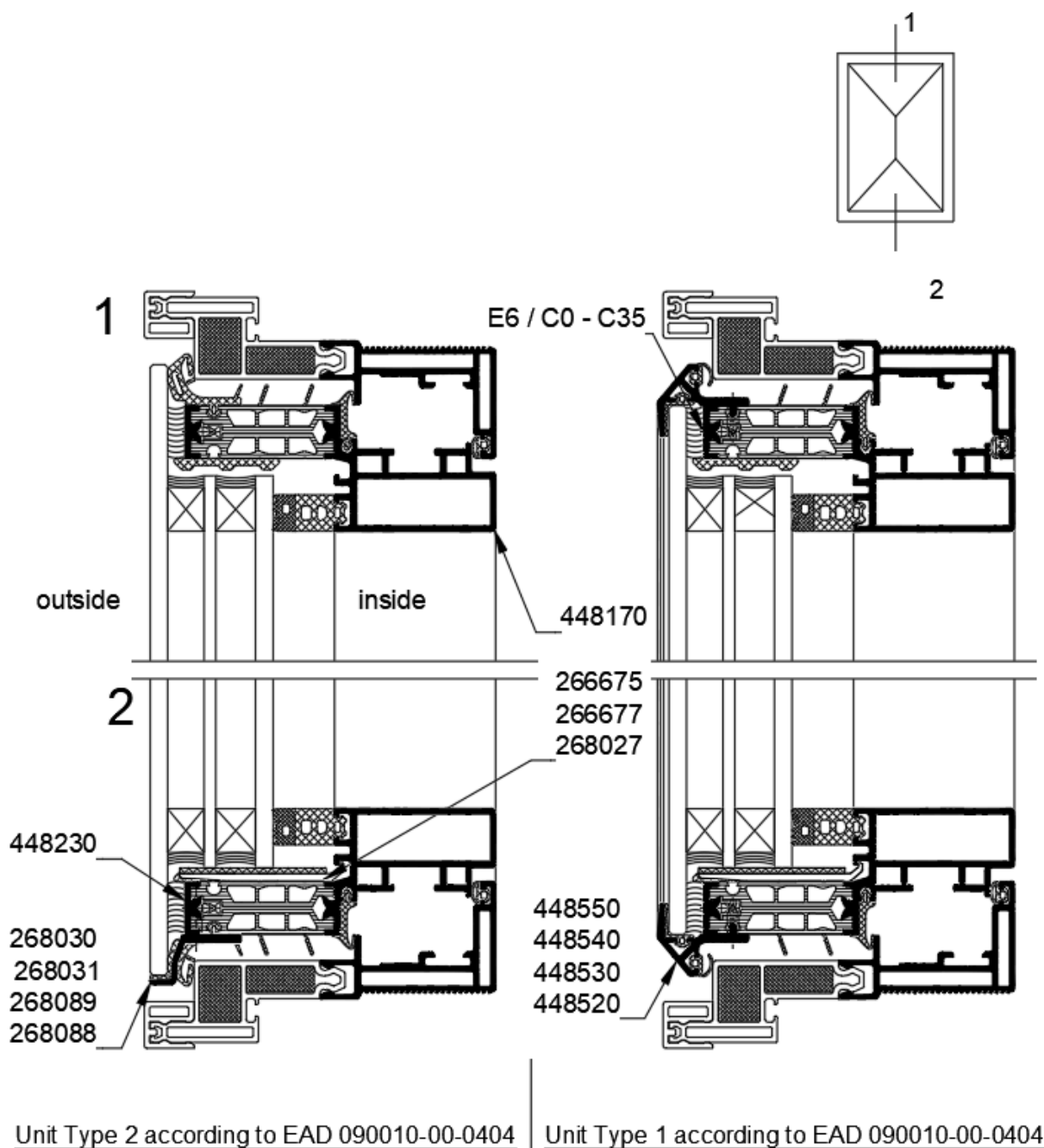





Glass support for insert elements also referred in annex 7

Bonded sealant glazing opening units for facade constructions
Schüco AWS 114 SG und Schüco AWS 114 SG.SI

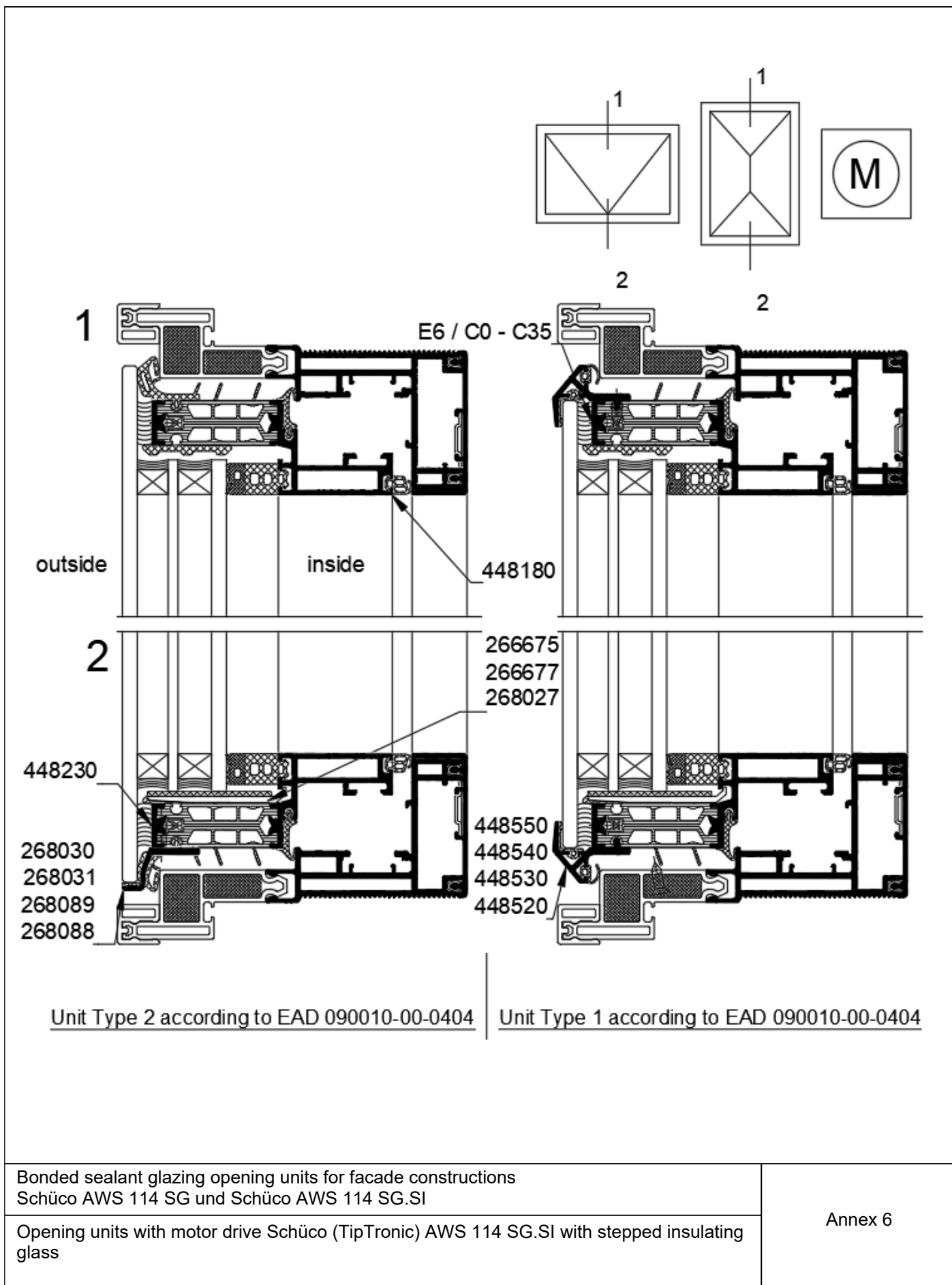
Parallel opening window Schüco AWS 114 SG.SI with stepped insulating glass

Annex 5



	Art. - No.	dimension X	dimension Y
AWS 114 SG			
	266673	30.2	-
	266674	38.2	-
AWS 114 SG AWS 114 SG.SI			
	268030	11.5	15.5
	268031	7.5	15.5
	268089	11.5	20.5
	268088	7.5	20.5
AWS 114 SG.SI			
	266675	44.2	-
	266677	50.2	-
	268027	56.2	-

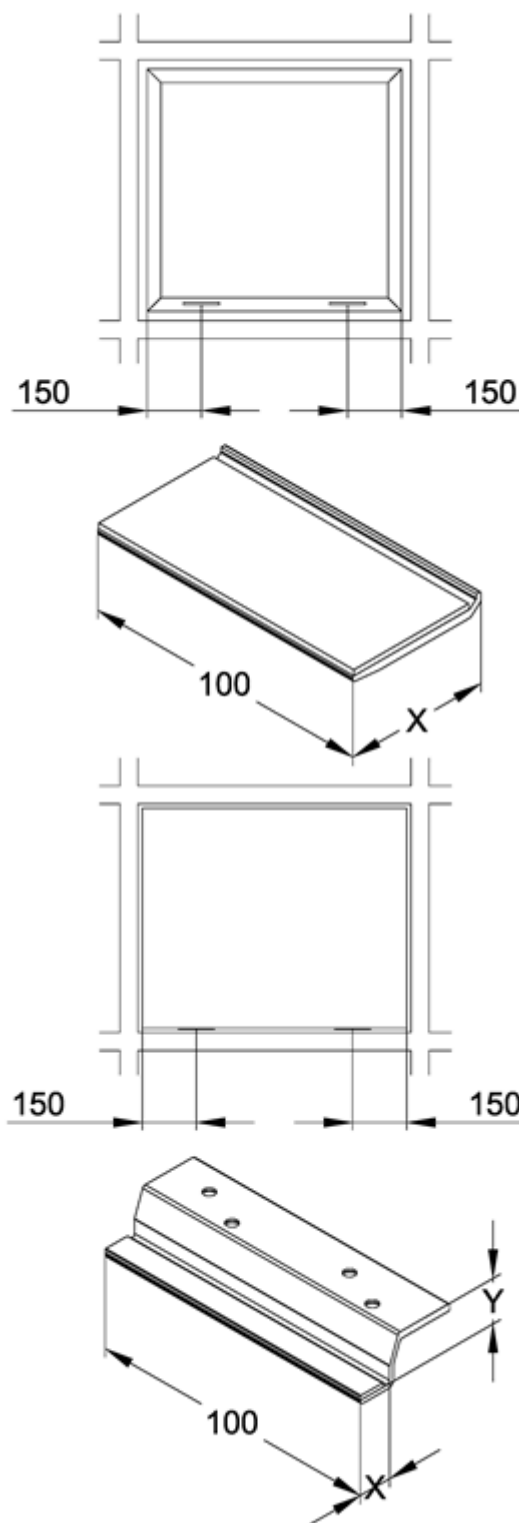

Bonded sealant glazing opening units for facade constructions
Schüco AWS 114 SG und Schüco AWS 114 SG.SI

Glass support for inner and outer panes

Annex 7

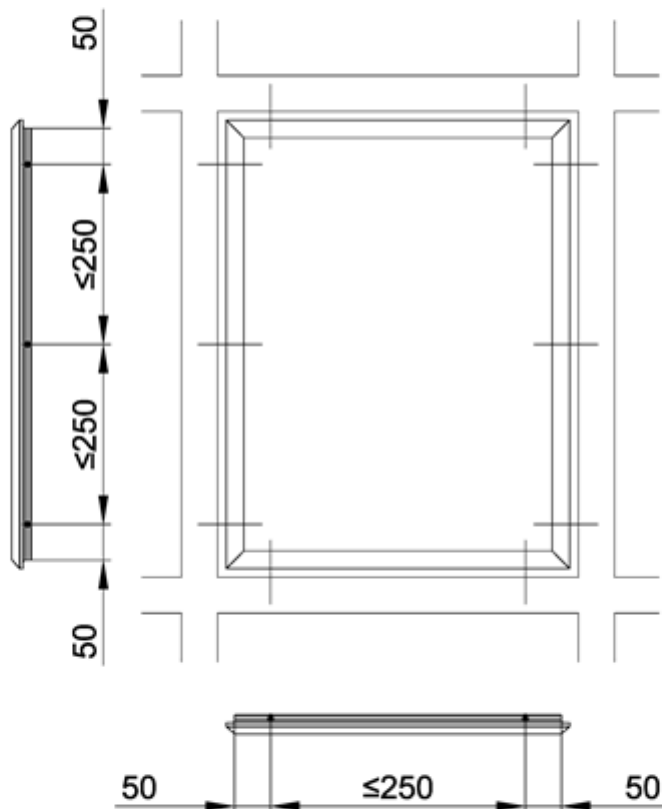

AWS 114 SG		AWS 114 SG.SI
Art. - No.		Art. - No.
448320		448520
448330		448530
448500		448540
448510		448550



Bonded sealant glazing opening units for facade constructions
 Schüco AWS 114 SG und Schüco AWS 114 SG.SI

Glass retention frame for mechanical protection

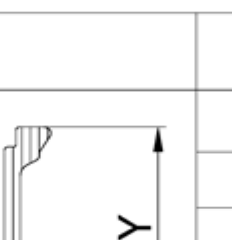
Annex 8

system		Art. - No.	material	width Y [mm]
AWS 114 SG		224072	Polythermid ®	17,5
		244572	Polythermid ®	22,5
		224078	Polythermid ®	27,5
		224084	Polythermid ®	32,5
		244312	Polythermid ®	37,5
AWS 114 SG.SI		284792	Polythermid ®	37
		284793	Polythermid ®	37
		284794	Polythermid ®	43
		284795	Polythermid ®	43
		284796	Polythermid ®	49
		284797	Polythermid ®	49
		284798	Polyamid	55

Bonded sealant glazing opening units for facade constructions
Schüco AWS 114 SG und Schüco AWS 114 SG.SI

Composite strips for Schüco AWS 114 SG and Schüco AWS 114 SG.SI

Annex 9