

Public-law institution jointly founded by the federal states and the Federation

European Technical Assessment Body  
for construction products



## European Technical Assessment

ETA-16/0100  
of 20 April 2026

English translation prepared by DIBt - Original version in German language

### General Part

Technical Assessment Body issuing the European Technical Assessment:

Deutsches Institut für Bautechnik

Trade name of the construction product

ThermoScrew TS U8 Gecko

Product family to which the construction product belongs

Plastic anchor for fixing of external thermal insulation composite systems with rendering

Manufacturer

Kunststoff-erzeugnisse GmbH Wilthen  
Dresdener Straße 19  
02681 Wilthen  
DEUTSCHLAND

Manufacturing plant

manufacturing plant 1, 2

This European Technical Assessment contains

15 pages including 3 annexes which form an integral part of this assessment

This European Technical Assessment is issued in accordance with Article 95(4) of Regulation (EU) No 2024/3110, on the basis of

EAD 330196-01-0604

This version replaces

ETA-16/0100 issued on 5 April 2016

The European Technical Assessment is issued by the Technical Assessment Body in its official language. Translations of this European Technical Assessment in other languages shall fully correspond to the original issued document and shall be identified as such.

Communication of this European Technical Assessment, including transmission by electronic means, shall be in full. However, partial reproduction may only be made with the written consent of the issuing Technical Assessment Body. Any partial reproduction shall be identified as such.

This European Technical Assessment may be withdrawn by the issuing Technical Assessment Body, in particular pursuant to information by the Commission in accordance with Article 36(3) of Regulation (EU) No 2024/3110.

## Specific Part

### 1 Technical description of the product

The Screwed-in anchor ThermoScrew TS U8 consists of an anchor sleeve made of polypropylene (virgin material) and a screw plate in different colours made of polyamide (virgin material) and an accompanying specific screw of galvanised steel.

The product description is given in Annex A.

### 2 Specification of the intended use in accordance with the applicable European Assessment Document

The performances given in Section 3 are only valid if the anchor is used in compliance with the specifications and conditions given in Annex B.

The verifications and assessment methods on which this European Technical Assessment is based lead to the assumption of a working life of the anchor of at least 25 years. The indications given on the working life cannot be interpreted as a guarantee given by the producer, but are to be regarded only as a means for choosing the right products in relation to the expected economically reasonable working life of the works.

### 3 Performance of the product and references to the methods used for its assessment

#### 3.1 Safety and accessibility in use (BWR 4)

Essential characteristic	Performance
Characteristic load bearing capacity <ul style="list-style-type: none"><li>- Characteristic resistance under tension load</li><li>- Minimum edge distance and spacing</li></ul>	see Annex C 1 and C 2 see Annex B 2
Displacements	see Annex C 3
Plate stiffness	no performance assessed

#### 3.2 Energy economy and heat retention (BWR 6)

Essential characteristic	Performance
Point thermal transmittance	no performance assessed

### 4 Assessment and verification of constancy of performance (AVCP) system applied, with reference to its legal base

In accordance with EAD No. 330196-01-0604, the applicable European legal act is: [97/463/EC].

The system to be applied is: 2+

**5 Technical details necessary for the implementation of the AVCP system, as provided for in the applicable European Assessment Document**

Technical details necessary for the implementation of the AVCP system are laid down in the control plan deposited with Deutsches Institut für Bautechnik.

Issued in Berlin on 20 April 2026 by Deutsches Institut für Bautechnik

Dipl.-Ing. Beatrix Wittstock  
Head of Section

*beglaubigt:*  
Ziegler

### Installed condition ThermoScrew TS U8 Gecko for OLD RENDER

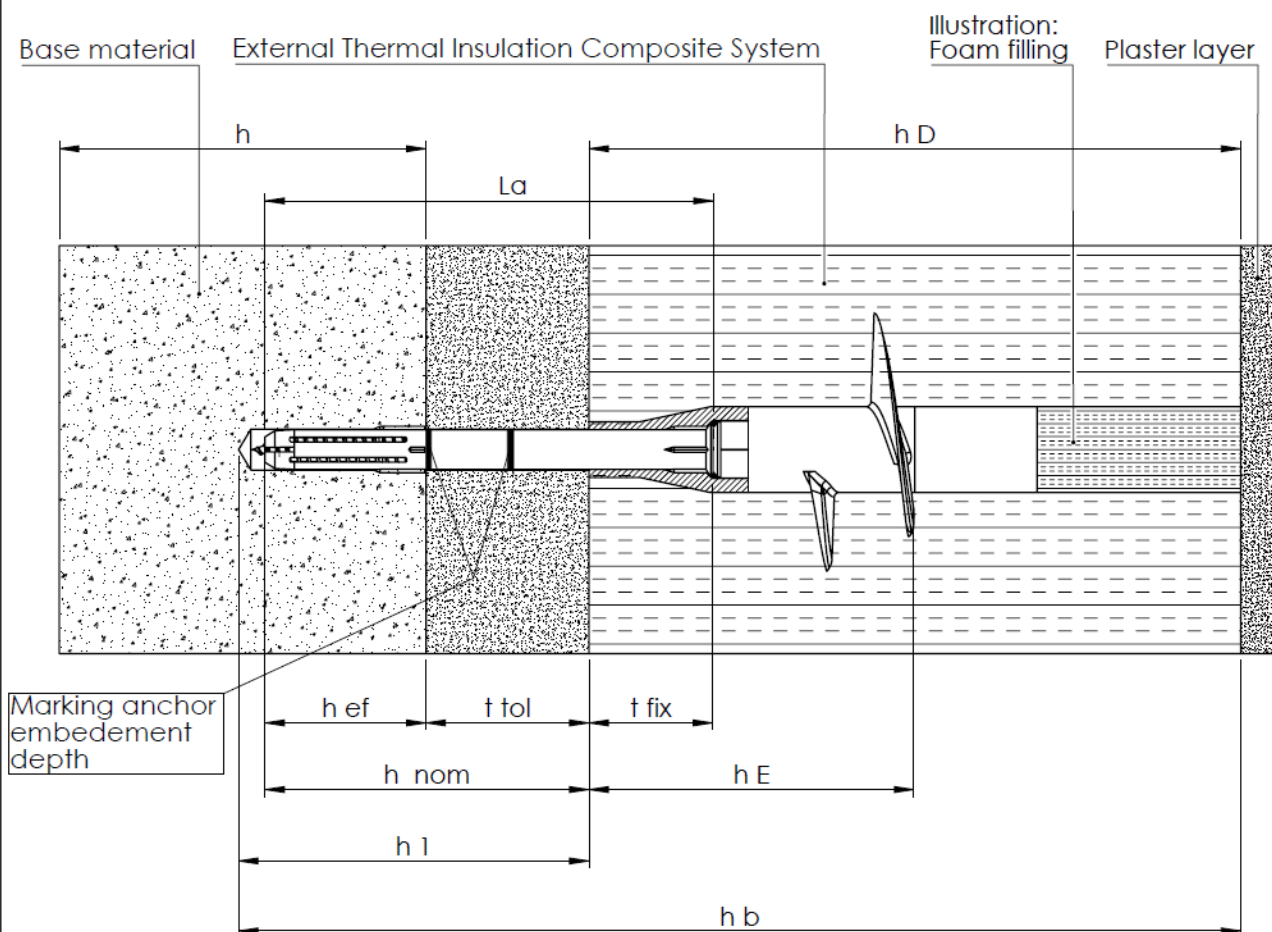

Marking anchor  
embedment  
depth

#### Legend

- $h_{nom}$  = overall plastic anchor embedment depth in the base material with non-load-bearing layer ( $t_{tol}$ )
- $h_{ef}$  = effective anchorage depth
- $h_1$  = depth of drilled hole to deepest point
- $h$  = thickness of member (wall)
- $h_D$  = thickness of insulation material
- $t_{tol}$  = thickness of equalizing layer and/or non-load-bearing layer
- $t_{fix}$  = position of screw plate
- $h_E$  = embedment depth
- $h_b$  = total borehole depth
- $La$  = total length of anchor

**ThermoScrew TS U8 Gecko**

**Product description**  
Installed condition for OLD RENDER

**Annex A 1**

### Installed condition ThermoScrew TS U8 Gecko for NEW BUILDING

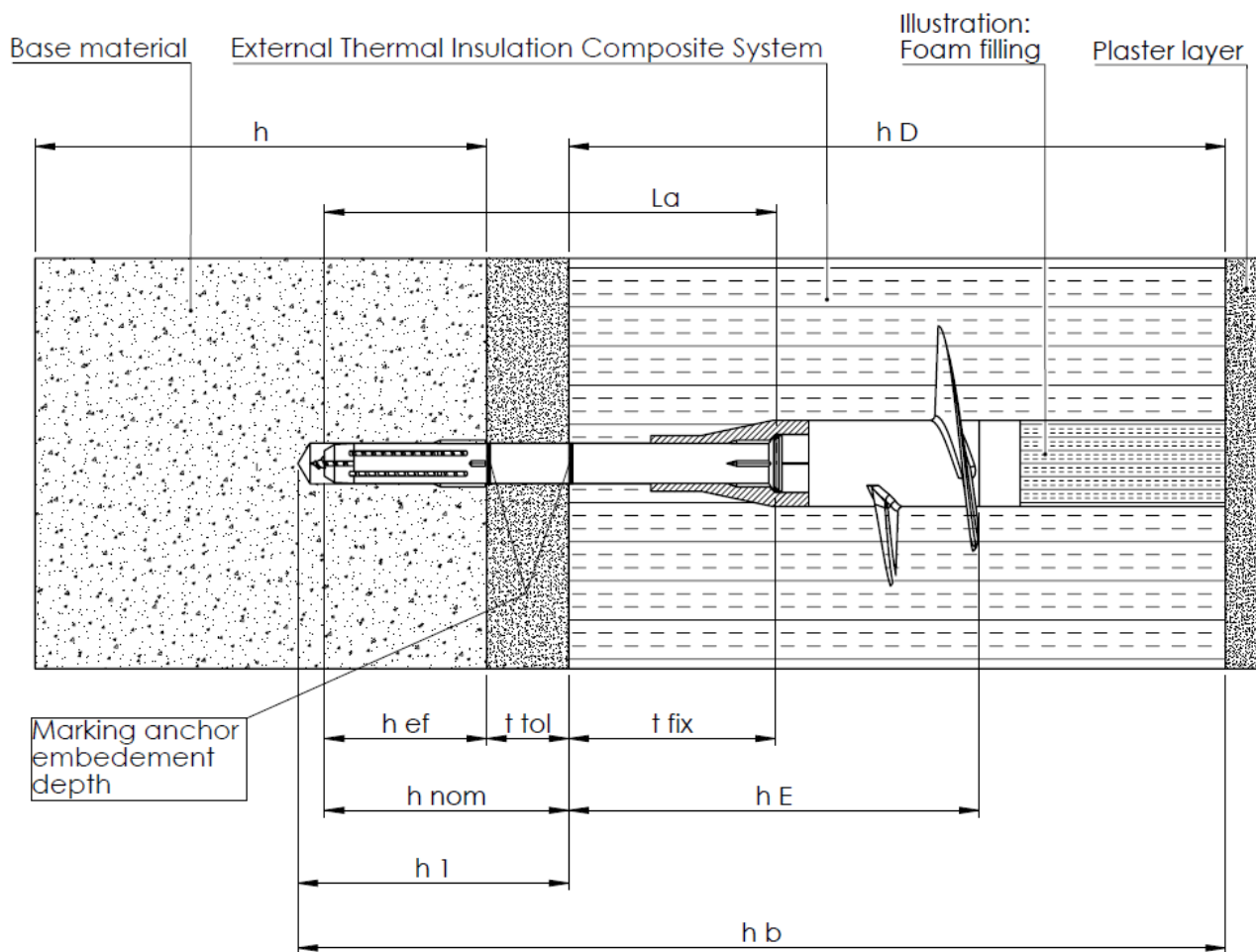

#### Legend

- $h_{nom}$  = overall plastic anchor embedment depth in the base material with non-load-bearing layer ( $t_{tol}$ )
- $h_{ef}$  = effective anchorage depth
- $h_1$  = depth of drilled hole to deepest point
- $h$  = thickness of member (wall)
- $h_D$  = thickness of insulation material
- $t_{tol}$  = thickness of equalizing layer and/or non-load-bearing layer
- $t_{fix}$  = position of screw plate
- $h_E$  = embedment depth
- $h_b$  = total borehole depth
- $L_a$  = total length of anchor

**ThermoScrew TS U8 Gecko**

**Product description**  
Installed condition for NEW BUILDING

**Annex A 2**

### Screw plate ThermoScrew TS U8 Gecko

**Labeling:**

Manufacturer: KEW  
Product name: TS U8 Gecko  
Base material group A, B, C, D, E

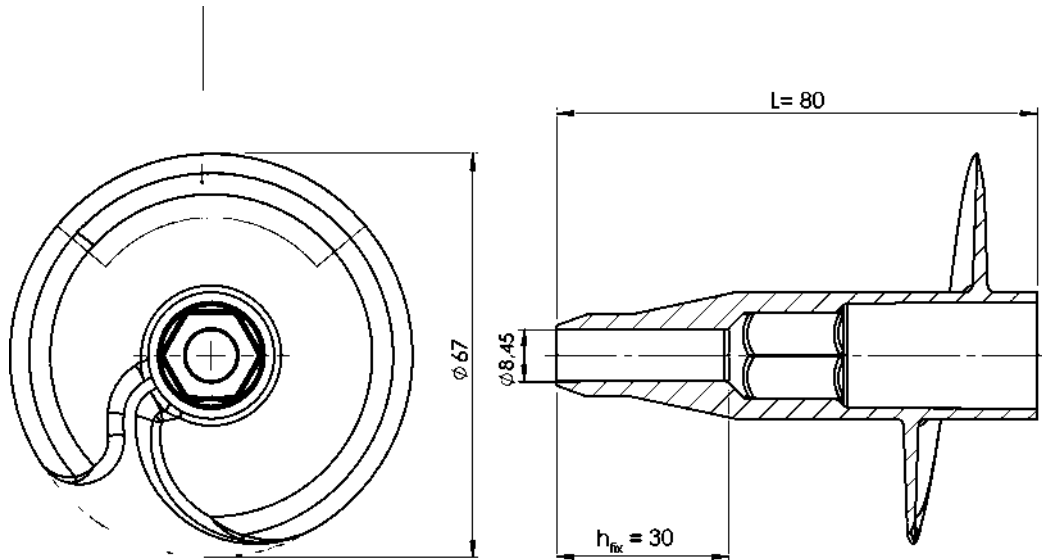

### Anchor sleeve TSD WSG with special screw (ETA-08/0314)

Anchor sleeve TSD WSG

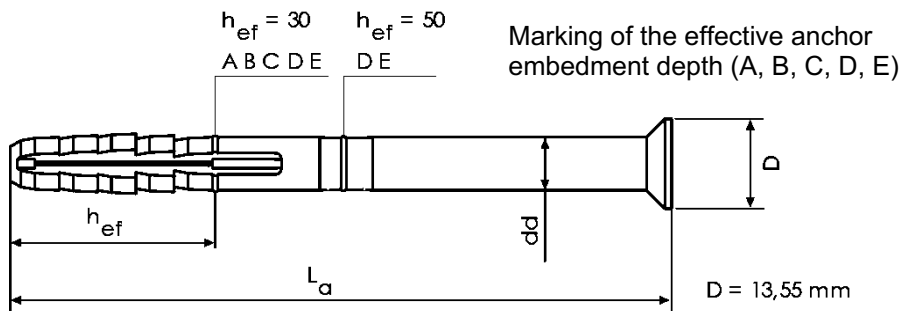

Special screw

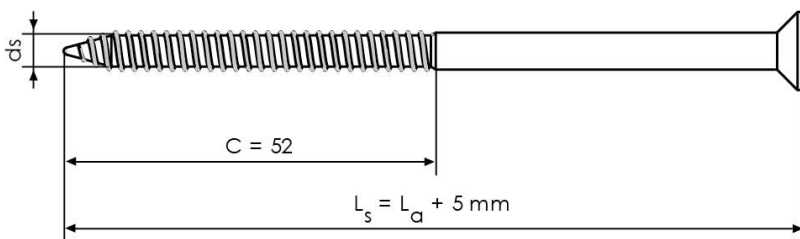

Insulation plug

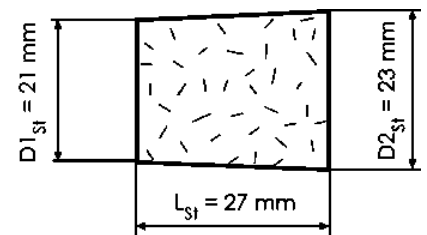

ThermoScrew TS U8 Gecko

**Product description**

Marking and dimension of the Screw plate, anchor sleeve, special screw, insulation plug

Annex A 3

**Table A1: Dimensions**

Anchor type	Anchor sleeve			Special screw		
	$d_d$ [mm]	$L_a$ [mm]	$h_{ef}$ [mm]	$d_s$ [mm]	$c$ [mm]	$L_s$ [mm]
<b>TSBD WSG</b> Base material group A, B, C, D, E	8	100 - 250	30	5,5	52	$L_a + 5\text{mm}$
<b>TSBD WSG</b> Base material group D, E	8	100 - 250	50	5,5	52	$L_a + 5\text{mm}$

Anchor type	Screw plate		
	$d$ [mm]	$L$ [mm]	$h_{fix}$ [mm]
<b>ThermoScrew TS U8 Gecko</b> Base material group A, B, C, D, E	67	80	30

**Table A2: Materials**

Element	Material
Screw plate	Virgin polyamide PA 6.6, colour: red, white, green, yellow, orange, blue, black, grey
Anchor sleeve	Virgin polypropylene (colour: nature or grey)
Special screw	Steel, electro galvanized $\geq 5 \mu\text{m}$ according to EN ISO 4042:2022, or non-electrolytically applied zinc flake coatings $\geq 5 \mu\text{m}$ in accordance with EN ISO 10683:2018 or stainless steel grade 1.4401, 1.4404 in accordance with EN 10088-3:2014
Insulation plug	polystyrene

**Setting and screwing tool TS SW**

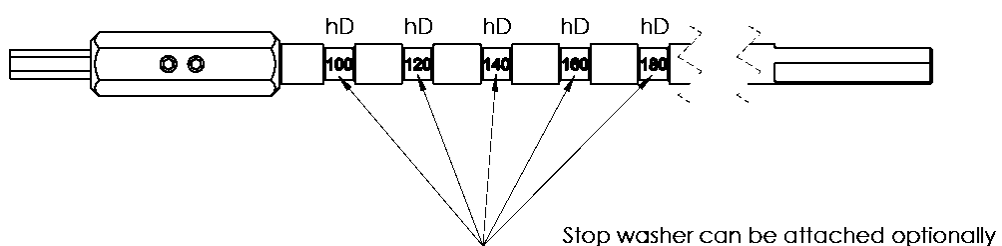

**Stop washer**



**ThermoScrew TS U8 Gecko**

**Product description**  
Dimensions, materials, setting tool

**Annex A 4**

## Specifications of intended use

### Anchorage subject to:

- The anchor may only be used for transmission of wind suction loads and shall not be used for the transmission of dead loads of the thermal insulation composite system.

### Base materials:

- Compacted normal weight concrete without fibres (base material group A) according to Annex C 1.
- Solid masonry (base material group B), according to Annex C 1.
- Hollow or perforated masonry (base material group C), according to Annex C 1.
- Lightweight aggregate concrete (base material group D), according to Annex C 2.
- Autoclaved aerated concrete (base material group E), according to Annex C 2.
- For other base materials of the base material groups A, B, C, D or E the characteristic resistance of the anchor may be determined by job site tests according to EOTA Technical Report TR 051 edition April 2018.

### Temperature Range:

- 0°C to +40°C (max. short term temperature +40°C and max. long term temperature +24°C)

### Design:

- The anchorages are designed under the responsibility of an engineer experienced in anchorages and masonry work with the partial safety factors  $\gamma_M = 2,0$  and  $\gamma_F = 1,5$ , if there are no other national regulations.
- Verifiable calculation notes and drawings are prepared taking account of the loads to be anchored. The position of the anchor is indicated on the design drawings.
- Fasteners are only to be used for multiple fixings of thermal insulation composite systems.

### Installation:

- Hole drilling by the drill modes according to Annex C1.
- Anchor installation carried out by appropriately qualified personnel and under the supervision of the person responsible for technical matters of the site.
- Installation temperature from 0°C to +40°C.
- Exposure to UV due to solar radiation of the anchor not protected by rendering  $\leq 6$  weeks.

ThermoScrew TS U8 Gecko

Intended use  
Specifications

Annex B 1

**Tabelle B1: Installation parameters for OLD RENDER**

Anchor type		TSBD WSG
Base material group		A-B-C-D-E
Drill hole diameter	$d_0 =$ [mm]	8
Cutting diameter of drill bit	$d_{cut} \leq$ [mm]	8,45
Effective anchor embedment depth	$h_{ef} =$ [mm]	30
Thickness of equalizing layer	$t_{tol} \leq$ [mm]	40 – 190
Position of screw plate	$t_{fix} \leq$ [mm]	30
Depth of drilled hole to deepest point <sup>1)</sup>	$h_1 \geq$ [mm]	80 – 230
Required length of anchor <sup>2)</sup>	$L_a =$ [mm]	100 – 250
Thickness of insulation material	$h_D =$ [mm]	100 – 400
Total borehole depth	$h_b =$ [mm]	$h_D + h_1$

**Table B2: Installation parameters for NEW BUILDING**

Anchor type		TSBD WSG	
Base material group		A-B-C-D-E	D-E
Drill hole diameter	$d_0 =$ [mm]	8	8
Cutting diameter of drill bit	$d_{cut} \leq$ [mm]	8,45	8,45
Effective anchorage depth	$h_{ef} =$ [mm]	30	50
Thickness of equalizing layer	$t_{tol} \leq$ [mm]	20	
Position of screw plate	$t_{fix} \leq$ [mm]	50	30
Depth of drilled hole to deepest point <sup>1)</sup>	$h_1 \geq$ [mm]	60	80
Required length of anchor <sup>2)</sup>	$L_a =$ [mm]	100	
Thickness of insulation material	$h_D =$ [mm]	100 – 400	
Total borehole depth	$h_b =$ [mm]	$h_D + h_1$	

<sup>1)</sup>  $h_1 = h_{ef} + t_{tol} + 10$  mm

<sup>2)</sup>  $L_a = h_{ef} + t_{tol} + t_{fix}$

**Table B3: Scheme of distances and spacing**

Dübeltyp		TSBD WSG
Minimum spacing	$s_{min} =$ [mm]	100
Minimum edge distance	$c_{min} =$ [mm]	100
Minimum thickness of the base material	$h \geq$ [mm]	100

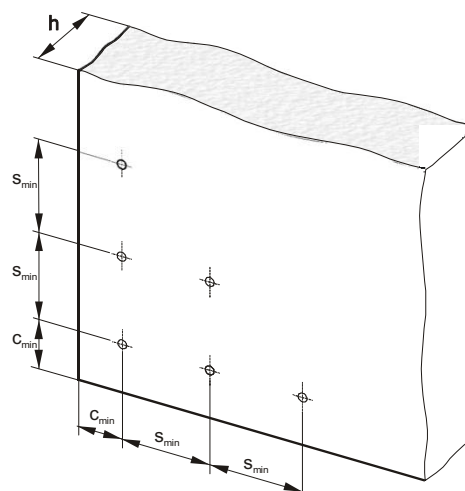

**ThermoScrew TS U8 Gecko**

**Intended use**

Installation parameters, distance and dimensions of the base material

**Annex B 2**

## Installation instructions for OLD RENDER

### 1. Attach stop washer to setting tool

For example with an insulation thickness of 16 cm = 160 mm attach the stop washer at "160".  
Note: Stop washer labeling "OLD RENDER" must face towards the applicator.

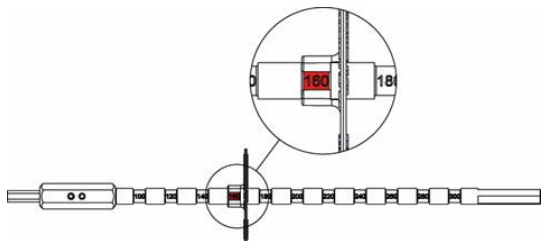

### 2. Install screw plate

Optionally, pre-drill the insulation panel. Position the ThermoScrew TS U8 Gecko spiral unit on the setting tool and press firmly against the insulation panel.

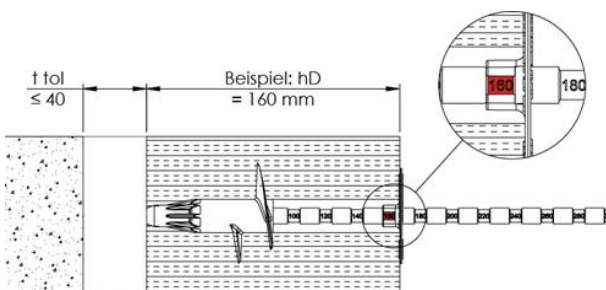
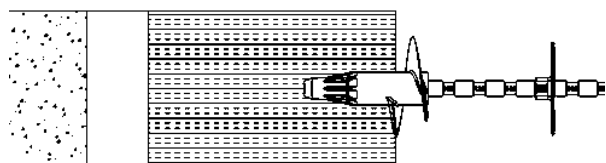

Slowly screw in the spiral unit at a low rotation setting until the stop washer is flush with the insulation board surface.

### 3. Drill hole with the drill bit

Total borehole depth  $h_b =$   
thickness of insulation material  $h_D + 80$  mm

Note: Ventilate the drill hole several times.  
When drilling in perforated brick and aerated concrete only use rotary drilling without hammer.

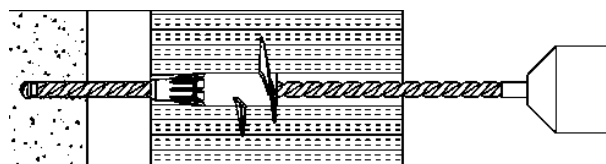

### 4. Position screw anchor and install

Using the setting tool, position the anchor through the spiral unit beneath the surface until the anchor sleeve stands out in the recess of the spiral unit. Screw the fixing.

Note: If the screw is stripped, a new screw plate must be installed.

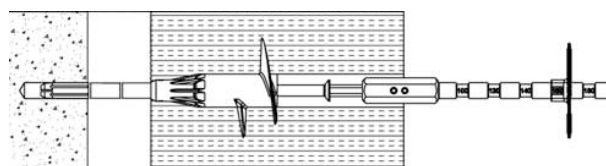

### 5. Closing the borehole in the insulation

Close the borehole with an insulation plug. Alternatively, fill the borehole with a suitable foam, approved by the system designer.

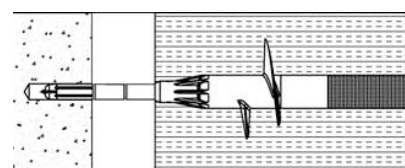

**ThermoScrew TS U8 Gecko**

**Intended use**

Installation instructions for OLD RENDER

**Annex B 3**

## Installation instructions for NEW BUILDING

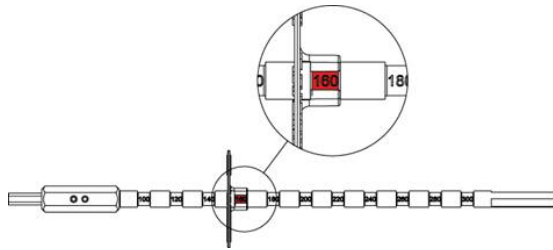

### 1. Attach stop washer to setting tool

For example with an insulation thickness of 16 cm = 160 mm attach the stop washer at "160".  
Note: Position stop washer labeling "NEW BUILDING" must face towards the applicator.

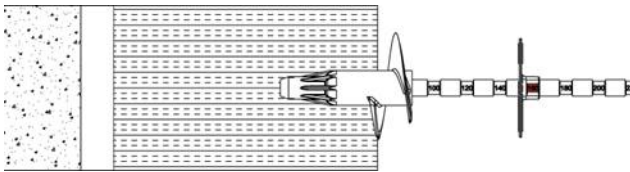

### 2. Install screw plate

Optionally, pre-drill the insulation panel. Position the ThermoScrew TS U8 Gecko spiral unit on the setting tool and press firmly against the insulation panel.

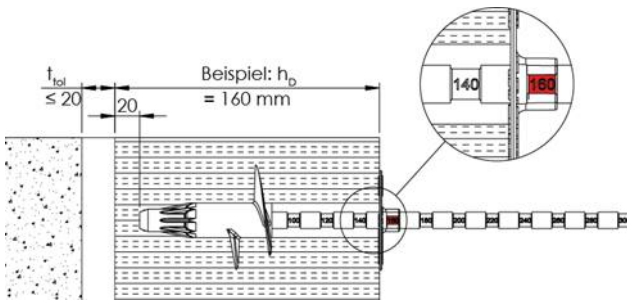

Slowly screw in the spiral unit at a low rotation setting until the stop washer is flush with the insulation board surface.

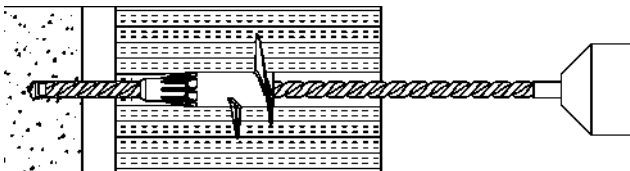

### 3. Drill hole with the drill bit

Total borehole depth  $h_b$  = thickness of insulation material  $h_D$  + 60 mm

Note: Ventilate the drill hole several times.  
When drilling in perforated brick and aerated concrete only use rotary drilling without hammer.

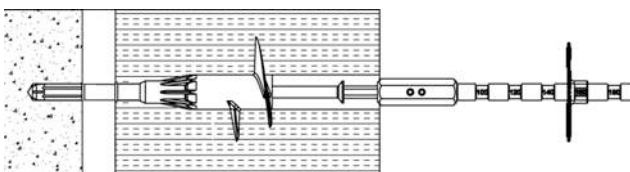

### 4. Position screw anchor and install

Using the setting tool, position the anchor through the spiral unit beneath the surface until the anchor sleeve stands out in the recess of the spiral unit. Screw the fixing.

Note: If the screw is stripped, a new screw plate must be installed.

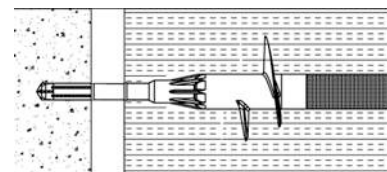

### 5. Closing the borehole in the insulation

Close the borehole with an insulation plug. Alternatively, fill the borehole with a suitable foam, approved by the system designer.

ThermoScrew TS U8 Gecko

Intended use  
Installation instructions for NEW BUILDING

Annex B 4

**Table C1: Characteristic resistance to tension loads  $N_{Rk}$  [kN] in concrete and masonry for single anchor**

Anchor type					TSBD WSG
Base material	Bulk density $\rho$ [kg/dm <sup>3</sup> ]	Minimum compressive strength $f_b$ [N/mm <sup>2</sup> ]	General remarks	Drilling method <sup>1)</sup>	$N_{Rk}$ [kN]
Concrete C12/15 as per EN 206:2013+A1:2016			Compacted normal weight concrete without fibres	H	1,5
Concrete C16/20 – C50/60 as per EN 206:2013+A1:2016			Compacted normal weight concrete without fibres	H	1,5
Sand-lime solid bricks (calcium silikate), KS as per EN 771-2:2011+A1:2015	≥ 1,8	12	Vertically perforation <sup>2)</sup> up to 15%	H	1,5
Clay brick, Mz as per EN 771-1:2011+A1:2015	≥ 1,7	12	Vertically perforation <sup>2)</sup> up to 15%	H	1,5
Lightweight concrete solid block, Vbl as per EN 771-3:2011+A1:2015	≥ 0,8	2	outer web thickness ≥ 43 mm <sup>3)</sup>	H	0,75
Lightweight concrete solid block, Vbl as per EN 771-3:2011+A1:2015	≥ 0,8	4	outer web thickness ≥ 43 mm <sup>3)</sup>	H	1,2
Perforated clay bricks, HLz as per EN 771-1:2011+A1:2015	≥ 1,0	12	Vertically perforation <sup>2)</sup> > 15 % and ≤ 50 % outer web thickness ≥ 12 mm <sup>3)</sup>	D	0,9
Perforated sand-lime bricks, KSL as per EN 771-2:2011+A1:2015	≥ 1,4	12	Vertically perforation <sup>2)</sup> > 15 % and ≤ 50 % outer web thickness ≥ 12 mm <sup>3)</sup>	D	1,5
Lightweight concrete hollow block, 4K Hbl as per EN 771-3:2011+A1:2015	≥ 0,9	2	outer web thickness ≥ 30 mm <sup>3)</sup>	D	0,75
Lightweight concrete hollow block 1K Hbl as per EN 771-3:2011+A1:2015	≥ 0,8	2	outer web thickness ≥ 30 mm <sup>3)</sup>	D	0,9

<sup>1)</sup> H = hammer drill, D = rotary drill

<sup>2)</sup> Cross section reduced by perforation vertically to the resting area

<sup>3)</sup> The value for  $N_{Rk}$  applies only for the given minimum outer web thickness; otherwise the characteristic resistance shall be determined by job site pull-out tests.

**ThermoScrew TS U8 Gecko**

**Performances**

Characteristic tension resistance

**Annex C 1**

**Table C1: Characteristic resistance to tension loads  $N_{Rk}$  [kN] in concrete and masonry for single anchor**

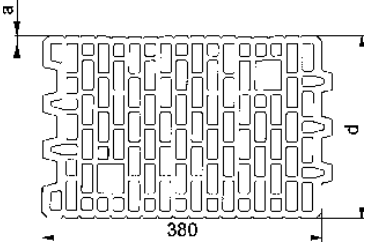
Anchor type					TSBD WSG
Base material	Bulk density $\rho$ [kg/dm <sup>3</sup> ]	Minimum compressive strength $f_b$ [N/mm <sup>2</sup> ]	General remarks	Drilling method <sup>1)</sup>	$N_{Rk}$ [kN]
Perforated clay bricks, HLz 250mm x 380mm x 235mm	$\geq 1,0$	6	 <p>Außenstegdicke <math>a \geq 16</math> mm <sup>2)</sup></p>	D	0,5
Lightweight aggregate concrete, as per EN 771-3:2011+A1:2015	$\geq 1,0$	4	$h_{ef} \geq 30$ mm	H	0,4
			$h_{ef} \geq 50$ mm	H	0,9
		6	$h_{ef} \geq 30$ mm	H	0,5
			$h_{ef} \geq 50$ mm	H	1,2
Autoclaved aerated concrete, as per EN 771-4:2011+A1:2015	$\geq 0,5$	4	$h_{ef} \geq 30$ mm	D	0,3
			$h_{ef} \geq 50$ mm	D	0,75

<sup>1)</sup> H = hammer drill, D = rotary drill

<sup>2)</sup> The value for  $N_{Rk}$  applies only for the given minimum outer web thickness; otherwise the characteristic resistance shall be determined by job site pull-out tests.

**ThermoScrew TS U8 Gecko**

**Performances**  
Characteristic tension resistance

**Annex C 2**

**Table C2: Displacements**

Base materials	Bulk density $\rho$ [kg/dm <sup>3</sup> ]	Minimum compressive strength $f_b$ [N/mm <sup>2</sup> ]	Tension load  N [kN]	Displacements  $\Delta \delta_N$ [mm]
Concrete C12/15 as per EN 206:2013+A1:2016			0,50	1,6
Concrete C16/20 – C50/60 as per EN 206:2013+A1:2016			0,50	1,6
Sand-lime solid bricks (calcium silikate), KS as per EN 771-2:2011+A1:2015	$\geq 1,8$	12	0,50	1,7
Clay brick, Mz as per EN 771-1:2011+A1:2015	$\geq 1,7$	12	0,50	1,7
Lightweight concrete solid block, Vbl as per EN 771-3:2011+A1:2015	$\geq 0,8$	2	0,25	1,0
Lightweight concrete solid block, Vbl as per EN 771-3:2011+A1:2015	$\geq 0,8$	4	0,40	1,5
Perforated clay bricks, HLz as per EN 771-1:2011+A1:2015	$\geq 1,0$	12	0,30	1,0
Perforated sand-lime bricks, KSL as per EN 771-2:2011+A1:2015	$\geq 1,4$	12	0,50	1,7
Lightweight concrete hollow block, 4K Hbl as per EN 771-3:2011+A1:2015	$\geq 0,9$	2	0,25	0,8
Lightweight concrete hollow block 1K Hbl as per EN 771-3:2011+A1:2015	$\geq 0,8$	2	0,30	1,1
Perforated clay bricks, HLz 250mm x 380mm x 235mm	$\geq 1,0$	6	0,15	0,6
Lightweight aggregate concrete, as per EN 771-3:2011+A1:2015	$\geq 1,0$	4	$h_{ef} > 30$ mm: 0,15	0,5
			$h_{ef} \geq 50$ mm: 0,30	1,1
		6	$h_{ef} > 30$ mm: 0,15	0,5
			$h_{ef} \geq 50$ mm: 0,40	1,3
Autoclaved aerated concrete, as per EN 771-4:2011+A1:2015	$\geq 0,5$	4	$h_{ef} > 30$ mm: 0,10	0,5
			$h_{ef} \geq 50$ mm: 0,25	0,7

**ThermoScrew TS U8 Gecko**

**Performances**  
Displacements

**Annex C 3**