

Public-law institution jointly founded by the federal states and the Federation

European Technical Assessment Body
for construction products



European Technical Assessment

ETA-17/0428
of 26 January 2026

English translation prepared by DIBt - Original version in German language

General Part

Technical Assessment Body issuing the European Technical Assessment:

Deutsches Institut für Bautechnik

Trade name of the construction product

Injection system ULTRAPROFI for masonry

Product family
to which the construction product belongs

Metal Injection anchors for use in masonry

Manufacturer

SEEFELDER GmbH
Dieselstraße 5
84088 Neufahrn in Niederbayern

Manufacturing plant

Seefelder

This European Technical Assessment
contains

51 pages including 3 annexes which form an integral part
of this assessment

This European Technical Assessment is
issued in accordance with Article 95(4) of
Regulation (EU) No 2024/3110, on the basis of

EAD 330076-01-0604

This version replaces

ETA-17/0428 issued on 14 December 2017

The European Technical Assessment is issued by the Technical Assessment Body in its official language. Translations of this European Technical Assessment in other languages shall fully correspond to the original issued document and shall be identified as such.

Communication of this European Technical Assessment, including transmission by electronic means, shall be in full. However, partial reproduction may only be made with the written consent of the issuing Technical Assessment Body. Any partial reproduction shall be identified as such.

This European Technical Assessment may be withdrawn by the issuing Technical Assessment Body, in particular pursuant to information by the Commission in accordance with Article 36(3) of Regulation (EU) No 2024/3110.

Specific Part

1 Technical description of the product

The Injection system ULTRAPROFI for masonry is a bonded anchor (injection type) consisting of a mortar cartridge with injection mortar ULTRAPROFI Installation mortar MT, ULTRAPROFI Installation mortar MT Low Speed or ULTRAPROFI Installation mortar MT High Speed, a perforated sieve sleeve and an anchor rod with hexagon nut and washer or an internal threaded rod. The steel elements are made of zinc coated steel, stainless steel or high corrosion resistant steel.

The anchor rod is placed into a drilled hole filled with injection mortar and is anchored via the bond between steel element, injection mortar and masonry and mechanical interlock.

The product description is given in Annex A.

2 Specification of the intended use in accordance with the applicable European Assessment Document

The performances given in Section 3 are only valid if the fastener is used in compliance with the specifications and conditions given in Annex B.

The verifications and assessment methods on which this European Technical Assessment is based lead to the assumption of a working life of the fastener of at least 50 years. The indications given on the working life cannot be interpreted as a guarantee given by the producer, but are to be regarded only as a means for choosing the right products in relation to the expected economically reasonable working life of the works.

3 Performance of the product and references to the methods used for its assessment

3.1 Mechanical resistance and stability (BWR 1)

Essential characteristic	Performance
Characteristic resistance for static and quasi-static loading	See Annexes B4 to B6, B13, B14, C1 to C28
Characteristic resistance and displacements for seismic loading	No performance assessed

3.2 Safety in case of fire (BWR 2)

Essential characteristic	Performance
Reaction to fire	Class A1
Resistance to fire under tension and shear loading with and without lever arm. Minimum edge distances and spacing	No performance assessed

3.3 Hygiene, health and the environment (BWR 3)

Essential characteristic	Performance
Content, emission and/or release of dangerous substances	No performance assessed

4 Assessment and verification of constancy of performance (AVCP) system applied, with reference to its legal base

In accordance with the European Assessment Document EAD 330076-01-0604 the applicable European legal act is: [97/177/EC].

The system to be applied is: 1

5 Technical details necessary for the implementation of the AVCP system, as provided for in the applicable European Assessment Document

Technical details necessary for the implementation of the AVCP system are laid down in the control plan deposited with Deutsches Institut für Bautechnik.

Issued in Berlin on 26 January 2026 by Deutsches Institut für Bautechnik

Dipl.-Ing. Beatrix Wittstock
Head of Section

beglaubigt:
Baderschneider

Installation conditions part 1

Anchor rods with perforated sleeve FIS H K; Installation in perforated and solid brick masonry

Pre-positioned installation:

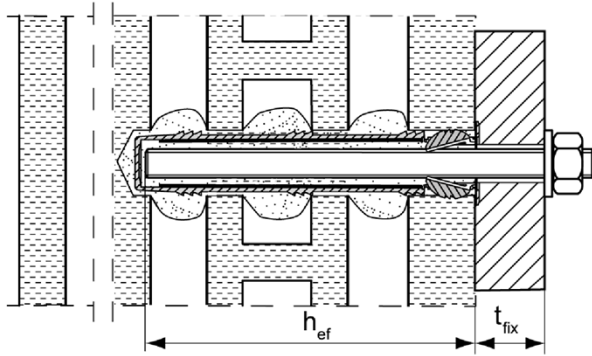

Installation with render bridge

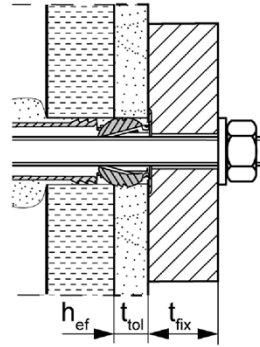

Size of the perforated sleeve: FIS H 12x50 K FIS H 16x85 K FIS H 20x85 K FIS H 20x200 K
 FIS H 12x85 K FIS H 16x130 K FIS H 20x130 K

Internal threaded anchor FIS E with perforated sleeve FIS H K; Installation in perforated and solid brick masonry

Pre-positioned installation:

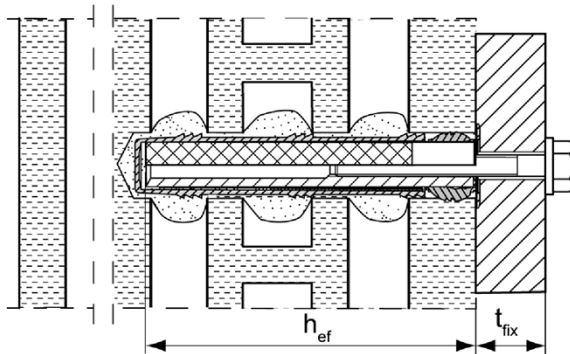

Figures not to scale

h_{ef} = effective anchorage depth

t_{tol} = thickness of unbearing layer (e.g. plaster)

t_{fix} = thickness of fixture

Injection system ULTRAPROFI for masonry

Product description

Installation conditions part 1,
Anchor rods and internal threaded anchor with perforated sleeve

Annex A1

Installation conditions part 2

**Anchor rods without perforated sleeve FIS H K;
installation in solid brick masonry and autoclaved aerated concrete**

Pre-positioned installation:

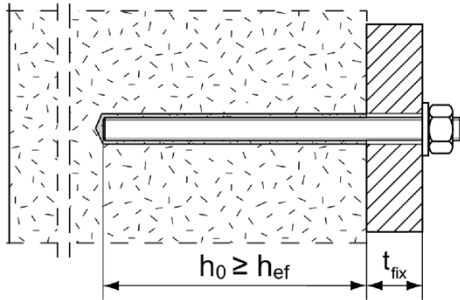

Push through installation: Annular gap filled with mortar

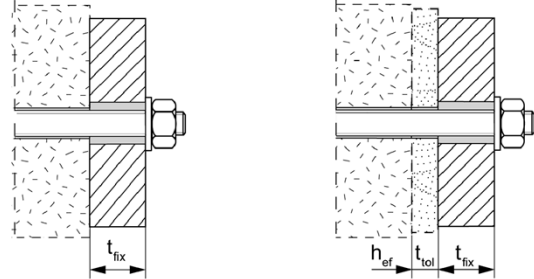

Installation with
render bridge

**Internal threaded anchors FIS E without perforated sleeve FIS H K;
installation in solid brick masonry and autoclaved aerated concrete**

Pre-positioned installation:

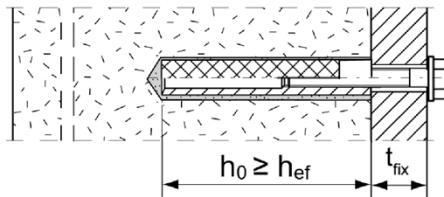

Installation with render bridge

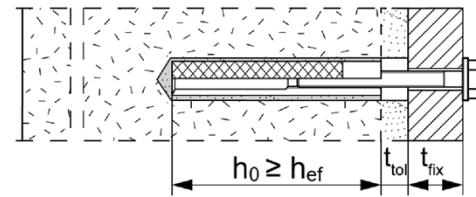

Figures not to scale

h_0 = depth of drill hole

t_{tol} = thickness of unbearing layer (e.g. plaster)

h_{ef} = effective anchorage depth

t_{fix} = thickness of fixture

Injection system ULTRAPROFI for masonry

Product description

Installation conditions part 2, Anchor rods and internal threaded anchor without perforated sleeve

Annex A2

Overview system components part 1

Mortar cartridge (shuttle cartridge) with sealing cap

①

Size: 360 ml, 825 ml

Imprint: ULTRAPROFI Installation mortar MT, ULTRAPROFI Installation mortar MT Low Speed, ULTRAPROFI Installation mortar MT High Speed, processing notes, shelf-life, hazard code, piston travel scale (optional), curing time and processing time (depending on temperature), size, volume

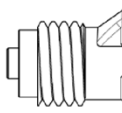
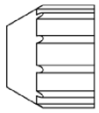

Mortar cartridge (coaxial cartridge) with sealing cap

①

Size: 100 ml, 150 ml, 300 ml, 380 ml, 400 ml, 410 ml

Imprint: ULTRAPROFI Installation mortar MT, ULTRAPROFI Installation mortar MT Low Speed, ULTRAPROFI Installation mortar MT High Speed, processing notes, shelf-life, hazard code, piston travel scale (optional), curing time and processing time (depending on temperature), size, volume

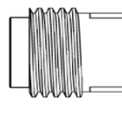
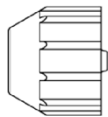

Static mixer FIS MR Plus for injection cartridges ≤ 410 ml

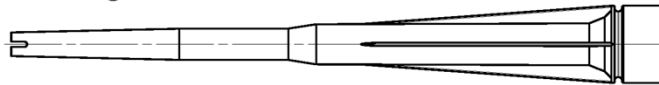

Static mixer FIS JMR for injection cartridges 825 ml

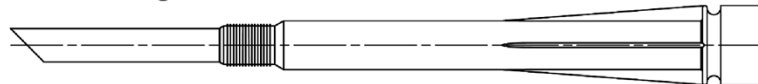

Extension tube $\varnothing 9$ for static mixer FIS MR Plus; Extension tube $\varnothing 9$ or $\varnothing 15$ for static mixer FIS JMR



Cleaning brush BS

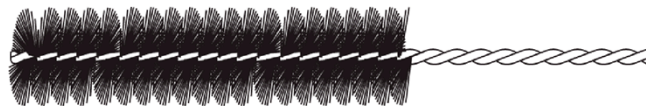

Blow-out pump ABG

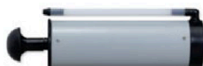

compressed-air cleaning tool ABP



Figures not to scale

Injection system ULTRAPROFI for masonry

Product description

Overview system components part 1: cartridge / static mixer / cleaning tools

Annex A3

Overview system components part 2

Anchor rod

②



Size: M6, M8, M10, M12, M16

Internal threaded anchor FIS E

⑤



Size: 11x85 M6 / M8
15x85 M10 / M12

Perforated sleeve FIS H K

⑦



Size: FIS H 12x50 K
FIS H 12x85 K
FIS H 16x85 K
FIS H 20x85 K

⑦



Size: FIS H 16x130 K
FIS H 20x130 K
FIS H 20x200 K

Washer

③

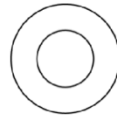

Hexagon nut

④



Figures not to scale



Injection system ULTRAPROFI for masonry

Product description

Overview system components part 2: steel parts / perforated sleeve

Annex A4

Table A5.1: Materials				
Part	Designation	Material		
1	Mortar cartridge	Mortar, hardener; filler		
		Steel	Stainless steel R	High corrosion resistant steel HCR
		zinc plated	acc. to EN 10088-1:2023 Corrosion resistance class CRC III acc. to EN 1993-1-4:2006+A1:2015	acc. to EN 10088-1:2023 Corrosion resistance class CRC V acc. to EN 1993-1-4:2006+A1:2015
2	Anchor rod	Property class 4.6; 4.8; 5.8 or 8.8; EN ISO 898-1: 2013 zinc plated $\geq 5\mu\text{m}$, ISO 4042:2022 or hot-dip galvanised EN ISO 10684:2004+AC:2009 $f_{uk} \leq 1000 \text{ N/mm}^2$ $A_5 > 8\%$ fracture elongation	Property class 50, 70 or 80 EN ISO 3506-1:2020 1.4401; 1.4404; 1.4578; 1.4571; 1.4439; 1.4362; 1.4062; 1.4662; 1.4462; EN 10088-1:2023 $f_{uk} \leq 1000 \text{ N/mm}^2$ $A_5 > 8\%$ fracture elongation	Property class 50 or 80 EN ISO 3506-1:2020 or property class 70 with $f_{yk} = 560 \text{ N/mm}^2$ 1.4565; 1.4529 EN 10088-1:2023 $f_{uk} \leq 1000 \text{ N/mm}^2$ $A_5 > 8\%$ fracture elongation
3	Washer ISO 7089:2000	zinc plated $\geq 5\mu\text{m}$, ISO 4042:2022 or hot-dip galvanised EN ISO 10684:2004+AC:2009	1.4401; 1.4404; 1.4578; 1.4571; 1.4439; 1.4362; EN 10088-1:2023	1.4565; 1.4529 EN 10088-1:2023
4	Hexagon nut	Property class 5 or 8; EN ISO 898-2:2022 zinc plated $\geq 5\mu\text{m}$, ISO 4042:2022 or hot-dip galvanised EN ISO 10684:2004+AC:2009	Property class 50, 70 or 80 EN ISO 3506-2:2020 1.4401; 1.4404; 1.4578; 1.4571; 1.4439; 1.4362; EN 10088-1:2023	Property class 50, 70 or 80 EN ISO 3506-2:2020 1.4565; 1.4529 EN 10088-1:2023
5	Internal threaded anchor FIS E	Property class 5.8; EN ISO 898-1:2013 zinc plated $\geq 5\mu\text{m}$, ISO 4042:2022	Property class 70 EN ISO 3506-1:2020 1.4401; 1.4404; 1.4578; 1.4571; 1.4439; 1.4362; EN 10088-1:2023	Property class 70 EN ISO 3506-1:2020 1.4565; 1.4529 EN 10088-1:2023
6	Commercial standard screw or threaded rod for internal threaded anchor FIS E	Property class 4.6, 5.8 or 8.8; EN ISO 898-1:2013 zinc plated $\geq 5\mu\text{m}$, ISO 4042:2022	Property class 70 EN ISO 3506-1:2020 1.4401; 1.4404; 1.4578; 1.4571; 1.4439; 1.4362; EN 10088-1:2023	Property class 70 EN ISO 3506-1:2020 1.4565; 1.4529 EN 10088-1:2023
7	Perforated sleeve	PP		
Injection system ULTRAPROFI for masonry				Annex A5
Product description Materials				

Specifications of intended use part 1			
Table B1.1: Overview use and performance categories			
Anchorages subject to		Injection system ULTRAPROFI for masonry	
Hole drilling with hammer drill mode 		all bricks	
Hole drilling with rotary drill mode 		all bricks	
Static and quasi static load, in masonry		all bricks	
Installation	Pre-positioned installation	Anchor rod or internal threaded anchor (in solid brick masonry and autoclaved aerated concrete)	Perforated sleeve with anchor rod or internal threaded anchor (in perforated and solid brick masonry) Size: FIS H 12x50 K FIS H 12x85 K FIS H 16x85 K FIS H 16x130 K FIS H 20x85 K FIS H 20x130 K FIS H 20x200 K
	Push through installation	Anchor rod; use in cylindrical drill hole (in solid brick masonry and autoclaved aerated concrete)	
Installation and use conditions	conditions d/d (dry/dry)	all bricks	
	conditions w/d (wet/dry)		
	conditions w/w (wet/wet)		
Installation direction		D3 (downward and horizontal installation)	
Installation temperature		$T_{i,min} = -5\text{ °C}$ to $T_{i,max} = +40\text{ °C}$	
In-service temperature	Temperature range Tb	-40 °C to +80 °C	(max. short term temperature +80 °C max. long term temperature +50 °C)
	Temperature range Tc	-40 °C to +120 °C	(max. short term temperature +120 °C; max. long term temperature +72 °C)
Injection system ULTRAPROFI for masonry		Annex B1	
Intended Use Specifications part 1			

Specifications of intended use part 2

Anchorage subject to:

- Static and quasi-static loads

Base materials:

- Solid brick masonry (base material group b) and autoclaved aerated concrete (base material group d), acc. to Annex B10.
- Hollow brick masonry (base material group c), according to Annex B10.
- For minimum thickness of masonry member is $h_{ef}+30\text{mm}$.
- Mortar strength class of the masonry M2,5 at minimum according to EN 998-2:2016.
- For other bricks in solid masonry, hollow or perforated masonry and autoclaved aerated concrete, the characteristic resistance of the anchor may be determined by job site tests according to EOTA Technical Report TR 053:2022-07 under consideration of the β -factor according to Annex C28, Table C28.1.

Note (only applies to solid bricks and autoclaved aerated concrete):

The characteristic resistance is also valid for larger brick sizes, higher compressive strength and higher raw density of the masonry unit.

Temperature Range:

- **Tb:** From -40°C to +80°C (max. short term temperature +80°C and max. long term temperature +50°C)
- **Tc:** From -40°C to +120°C (max. short term temperature +120°C and max. long term temperature +72°C)

Use conditions (Environmental conditions):

- Structures subject to dry internal conditions (zinc plated steel, stainless steel or high corrosion resistant steel)
- For all other conditions according to EN 1993-1-4:2006+A1:2015 corresponding to corrosion resistance classes to Annex A5, Table A5.1.

Injection system ULTRAPROFI for masonry

Intended Use
Specifications part 2

Annex B2

Specifications of intended use part 3 continued

Design:

- The anchorages have to be designed in accordance with EOTA Technical Report TR 054:2023-12, Design method A under the responsibility of a designer experienced in anchorages and masonry work.

Applies to all bricks, if no other values are specified:

$$N_{Rk} = N_{Rk,b} = N_{Rk,p} = N_{Rk,b,c} = N_{Rk,p,c}$$

$$V_{Rk} = V_{Rk,b} = V_{Rk,c,II} = V_{Rk,c,I}$$

For the calculation of pulling out a brick under tension loading $N_{Rk,pb}$ or

pushing out a brick under shear loading $V_{Rk,pb}$ see EOTA Technical Report TR 054:2023-12.

$N_{Rk,s}$, $V_{Rk,s}$ and $M^0_{Rk,s}$ see annexes C1-C3.

Factors for job site tests and displacements see annex C28.

- Verifiable calculation notes and drawings have to be prepared taking into account the relevant masonry in the region of the anchorage, the loads to be transmitted and their transmission to the supports of the structure. The position of the anchor is to be indicated on the design drawings.

Installation:

- Conditions d/d: - Installation and use in dry structures.
- Conditions w/w:- Installation and use in dry and wet structures.
- Conditions w/d: - Installation in wet structures and use in dry structures.
- Hole drilling see Annex C (drilling method).
- In case of aborted hole: The hole shall be filled with injection mortar.
- Bridging of unbearing layer (e.g., plaster) is permitted for masonry with solid bricks and cylindrical drill hole. At perforated brick masonry see Annex B6, Table B6.1.
- Anchor installation carried out by appropriately qualified personnel and under the supervision of the person responsible for technical matters of the site.
- Fastening screws or anchor rods (including nut and washer) must comply with the appropriate material and property class of the internal threaded anchor FIS E mentioned in Annex A5, Table A5.1.
- Minimum curing time see Annex B7, Table B7.3.
- Commercial standard threaded rods, washers and hexagon nuts may also be used if the following requirements are fulfilled:

Material dimensions and mechanical properties of the metal parts according to the specifications are given in Annex A5, Table A5.1

Conformation of material and mechanical properties of the metal parts by inspection certificate 3.1 according to EN 10204:2004, the documents shall be stored.

Marking of the anchor rod with the envisage embedment depth. This may be done by the manufacturer of the rod or by a person on job site.

Injection system ULTRAPROFI for masonry

Intended Use
Specifications part 3 continued

Annex B3

Table B4.1: Installation parameters for anchor rods in solid bricks and autoclaved aerated concrete without perforated sleeves

Anchor rod	Thread	M6	M8	M10	M12	M16
Nominal drill hole diameter	d_0 [mm]	8	10	12	14	18
Effective anchorage depth $h_{ef}^{1)}$ in AAC cylindrical drill hole	$h_{0,min} \geq h_{ef,min}$ [mm]	100				
	$h_{0,max} \geq h_{ef,max}$ [mm]	h-30, ≤ 200				
Effective anchorage depth $h_{ef}^{1)}$ in solid brick (depth of drill hole $h_0 \geq h_{ef}$)	$h_{ef,min}$ [mm]	50				
	$h_{ef,max}$ [mm]	h-30, ≤ 200				
Diameter of clearance hole in the fixture	pre-positioning $d_f \leq$ [mm]	7	9	12	14	18
	push through $d_f \leq$ [mm]	9	11	14	16	20
Diameter of cleaning brush	$d_b \geq$ [mm]	see Table B7.1				
Maximum installation torque	T_{inst} [Nm]	see parameters of brick				

¹⁾ $h_{ef,min} \leq h_{ef} \leq h_{ef,max}$ is possible.

Anchor rods M6, M8, M10, M12, M16



Marking (on random place) anchor rod:

Steel zinc plated PC ¹⁾ 8.8	• or +	Steel hot-dip galvanised PC ¹⁾ 8.8	•
High corrosion resistant steel HCR PC ¹⁾ 50	•	High corrosion resistant steel HCR PC ¹⁾ 70	–
High corrosion resistant steel HCR PC ¹⁾ 80	(Stainless steel R property class 50	~
Stainless steel R property class 80	*		

Alternatively: Colour coding according to DIN 976-1: 2016;
property class 4.6 marking according to EN ISO 898-1:2013

¹⁾ PC = property class

Installation conditions:

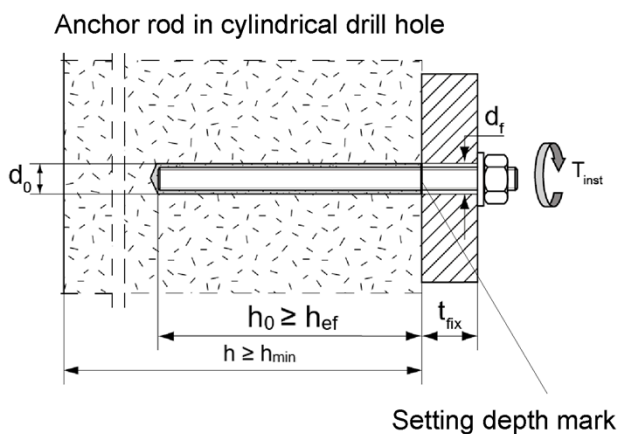

Figures not to scale

Injection system ULTRAPROFI for masonry

Intended Use
Installation parameters for anchor rods without perforated sleeve

Annex B4

Table B5.1: Installation parameters for internal threaded anchors FIS E in solid bricks and autoclaved aerated concrete without perforated sleeves

Internal threaded anchor FIS E		11x85 M6	11x85 M8	15x85 M10	15x85 M12
Diameter of anchor	d_H [mm]	11		15	
Nominal drill hole diameter	d_0 [mm]	14		18	
Length of anchor	L_H [mm]	85			
Effective anchorage depth	$h_0 \geq h_{ef}$ [mm]	85			
Diameter of cleaning brush	$d_b \geq$ [mm]	see Table B7.1			
Maximum installation torque	T_{inst} [Nm]	see parameters of brick			
Diameter of clearance hole in the fixture	d_f [mm]	7	9	12	14
Screw-in depth	$l_{E,min}$ [mm]	6	8	10	12
	$l_{E,max}$ [mm]	60			

Internal threaded anchor FIS E

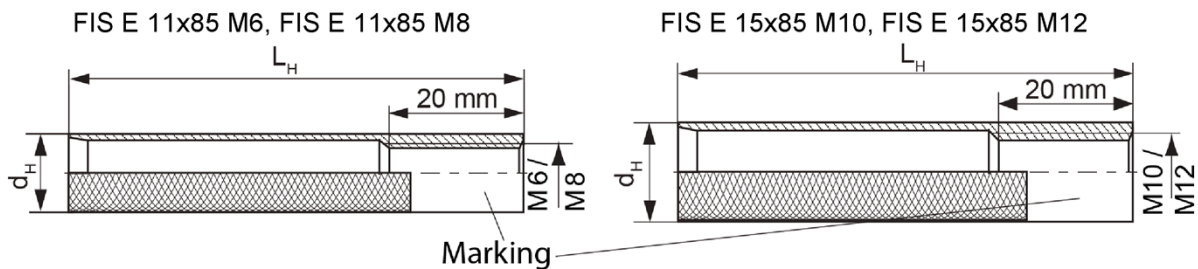

Marking:

Size, e.g. **M8**, Stainless steel: R, e.g. **M8 R**, High corrosion resistant steel: HCR, e.g. **M8 HCR**

Installation conditions:

Internal threaded anchor in cylindrical drill hole

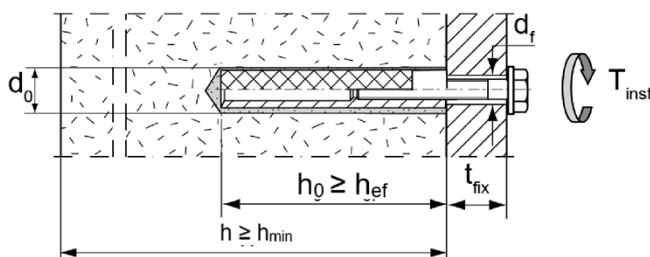

Figures not to scale

Injection system ULTRAPROFI for masonry

Intended Use

Installation parameters for internal threaded rods FIS E without perforated sleeve

Annex B5

Table B6.1: Installation parameters for anchor rods and internal threaded anchors FIS E with perforated sleeves (pre-positioned installation)

perforated sleeve FIS H K		12x50	12x85 ²⁾	16x85	16x130 ²⁾	20x85	20x130 ²⁾	20x200 ²⁾
Nominal drill hole diameter $d_0 = D_{\text{sleeve, nom}}$	d_0 [mm]	12		16		20		
Depth of drill hole	h_0 [mm]	55	90	90	135	90	135	205
Effective anchorage depth	$h_{\text{ef, min}}$ [mm]	50	65	85	110	85	110	180
	$h_{\text{ef, max}}$ [mm]	50	85	85	130	85	130	200
Size of threaded rod	[-]	M6 and M8		M8 and M10		M12 and M16		
Size of internal threaded anchor FIS E		-	-	11x85	-	15x85	-	-
Diameter of cleaning brush ¹⁾	$d_b \geq$ [mm]	see Table B7.1						
Maximum installation torque	T_{inst} [Nm]	see parameters of brick						

¹⁾ Only for solid areas in hollow bricks and solid bricks.

²⁾ Bridging of unbearing layer (e.g. plaster) is possible. When reducing the effective anchorage depth $h_{\text{ef, min}}$, the values of the next shorter perforated sleeve of the same diameter must be used. The smaller value of characteristic resistance must be taken.

Perforated sleeve

FIS H 12x50 K; FIS H 12x85 K; FIS H 16x85 K; FIS H 16x130 K;
FIS H 20x85 K; FIS H 20x130 K; FIS H 20x200 K

Marking:

Size $D_{\text{sleeve, nom}} \times L_{\text{sleeve}}$
(e.g.: 16x85)

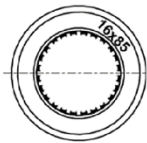

$D_{\text{sleeve, nom}}$

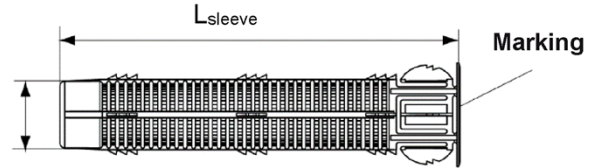

Internal threaded anchor FIS E

FIS E 11x85 M6, FIS E 11x85 M8

FIS E 15x85 M10, FIS E 15x85 M12

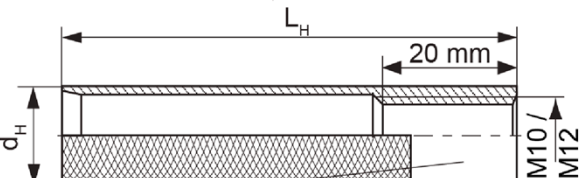
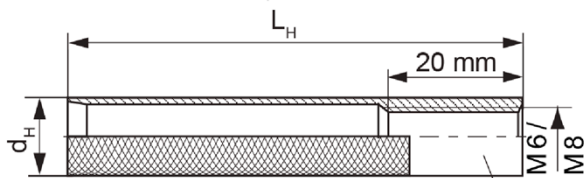

Marking

Installation conditions:

Anchor rod with perforated sleeve

Internal threaded anchor with perforated sleeve

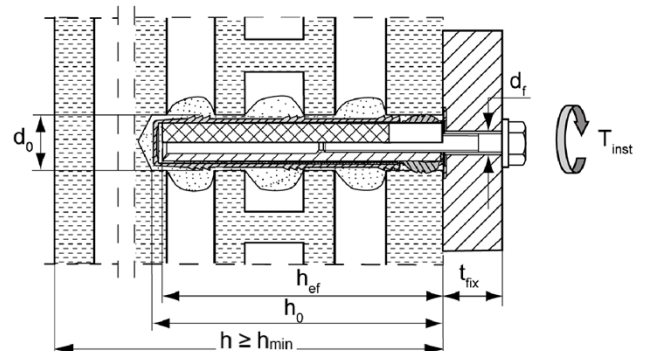
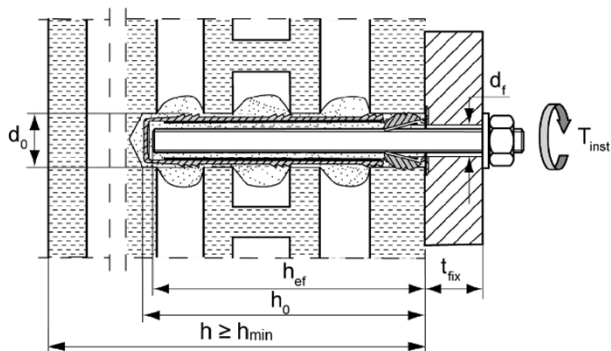

Figures not to scale

Injection system ULTRAPROFI for masonry

Intended Use

Installation parameters for anchor rods and internal threaded anchors FIS E with perforated sleeve (pre-positioned installation)

Annex B6

Table B7.1: Parameters of the cleaning brush BS (steel brush with steel bristles)

The size of the cleaning brush refers to the drill hole diameter

Drill hole diameter	d_0 [mm]	8	10	12	14	16	18	20
Brush diameter	d_b [mm]	9	11	14	16	20	20	25



Only for solid bricks and autoclaved aerated concrete or solid areas of perforated bricks and hollow blocks

Table B7.2: Conditions for use static mixer without an extension tube

Nominal drill hole diameter	d_0	[mm]	10	12	14	16	18	20
Drill hole depth h_0 by using	FIS MR Plus	[mm]	≤90		≤120	≤140	≤150	≤160
	FIS JMR	[mm]	-		≤90			≤260

Table B7.3: Maximum processing times and minimum curing times

(During the curing time of the mortar the masonry temperature may not fall below the listed minimum temperature)

Temperature at anchoring base [°C]	Maximum processing time ²⁾ t_{work}			Minimum curing time ^{1), 2)} t_{cure}		
	ULTRAPROFI Installation-mortar MT High Speed	ULTRAPROFI Installation-mortar MT	ULTRAPROFI Installation-mortar MT Low Speed	ULTRAPROFI Installation-mortar MT High Speed	ULTRAPROFI Installation-mortar MT	ULTRAPROFI Installation-mortar MT Low Speed
-10 to -5	-	-	-	12 h	-	-
> -5 to 0	5 min	-	-	3 h	24 h	-
> 0 to 5	5 min	13 min	-	3 h	3 h	6 h
> 5 to 10	3 min	9 min	20 min	50 min	90 min	3 h
> 10 to 20	1 min	5 min	10 min	30 min	60 min	2 h
> 20 to 30	-	4 min	6 min	-	45 min	60 min
> 30 to 40	-	2 min	4 min	-	35 min	30 min

¹⁾ For wet bricks the curing time must be doubled.

²⁾ Minimum cartridge temperature +5°C.

Figures not to scale

Injection system ULTRAPROFI for masonry



Intended Use

Cleaning brush (steel brush)
Maximum processing times and minimum curing times

Annex B7

Installation instruction part 1

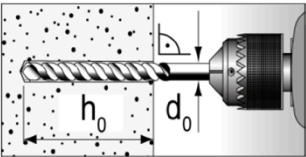
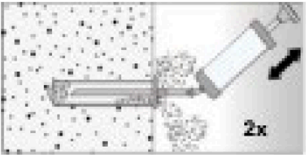
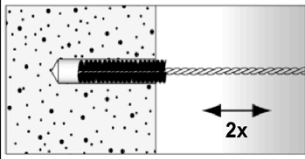
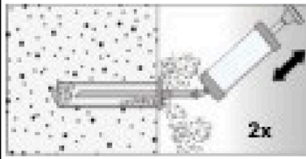
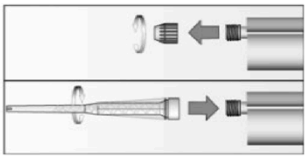
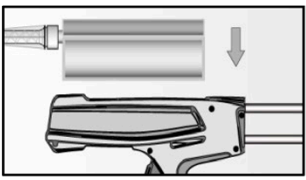
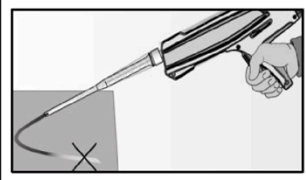
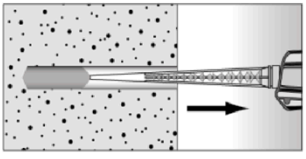
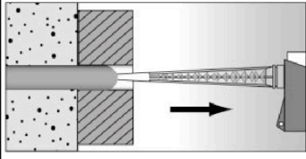
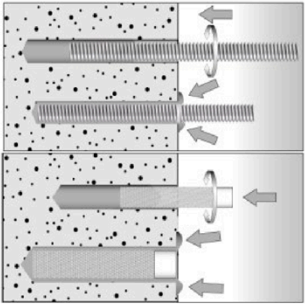
Installation in solid brick and autoclaved aerated concrete (without perforated sleeve)

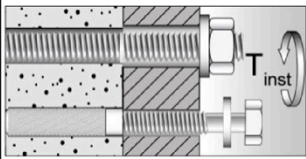
1		<p>Drill the hole (drilling method see Annex C of the respective brick) depth of drill hole h_0 and drill hole diameter d_0 see Table B4.1; B5.1.</p>	
2			 <p>Blow out the drill hole twice. Brush twice and blow out twice again.</p>
3		<p>Remove the sealing cap. Screw on the static mixer. (the spiral in the static mixer must be clearly visible).</p>	
4		<p>Place the cartridge into a suitable dispenser.</p>	 <p>Press out approximately 10 cm of mortar until the resin is permanently grey in colour. Mortar which is not grey in colour will not cure and must be disposed of.</p>
5		<p>Fill approximately 2/3 of the drill hole with mortar beginning from the bottom of the hole¹⁾. Avoid bubbles!</p>	 <p>For push through installation fill the annular clearance with mortar.</p>
6		<p>Only use clean and oil-free metal parts. Mark the anchor rod for setting depth. Insert the anchor rod or internal threaded anchor FIS E by hand using light turning motions. When reaching the setting depth marking, excess mortar must emerge from the mouth of the drill hole.</p>	
7		<p>Do not touch. Minimum curing time see Table B7.3.</p>	 <p>Mounting the fixture. max T_{inst} see parameter of brick in Annex C.</p>

¹⁾ Exact volume of mortar see manufacturer's specification.



Injection system ULTRAPROFI for masonry

Intended Use
Installation instruction (without perforated sleeve) part 1

Annex B8

Installation instruction part 2

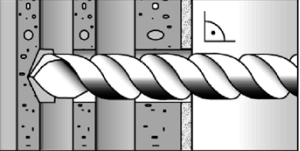
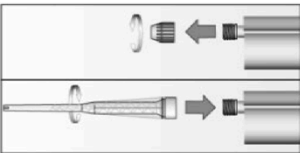
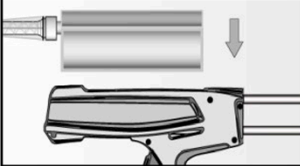
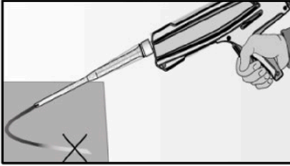
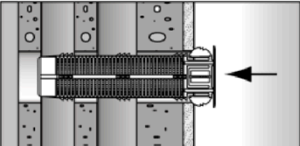
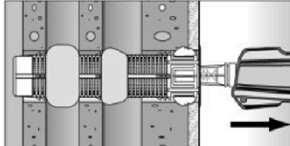
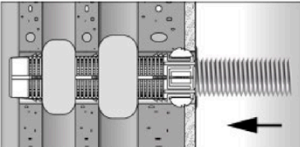
Installation in perforated or solid brick with perforated sleeve (pre-positioned installation)

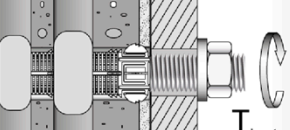
1		<p>Drill the hole (drilling method see Annex C of the respective brick). depth of drill hole h_0 and drill hole diameter d_0 see Table B6.1</p>	<p>When install perforated sleeves in solid bricks or solid areas of hollow bricks, also clean the hole by blowing out and brushing.</p>	
2		<p>Remove the sealing cap. Screw on the static mixer. (the spiral in the static mixer must be clearly visible).</p>		
3		<p>Place the cartridge into a suitable dispenser.</p>		<p>Press out approximately 10 cm of mortar until the resin is permanently grey in colour. Mortar which is not grey in colour will not cure and must be disposed of.</p>
4		<p>Insert the perforated sleeve flush with the surface of the masonry or plaster.</p>		<p>Fill the perforated sleeve completely with mortar beginning from the bottom of the hole¹⁾.</p>
5		<p>Only use clean and oil-free metal parts. Mark the anchor rod for setting depth. Insert the anchor rod or the internal threaded anchor FIS E by hand using light turning motions until reaching the setting depth marking (anchor rod) or flush with the surface (internal threaded anchor).</p>		
6		<p>Do not touch. Minimum curing time see Table B7.3</p>		<p>Mounting the fixture. max T_{inst} see parameter of brick in Annex C.</p>

¹⁾ Exact volume of mortar see manufacturer's specification.

Injection system ULTRAPROFI for masonry

Intended Use
Installation instruction (with perforated sleeve) part 2

Annex B9

Table B10.1: Overview of assessed bricks					
Kind of masonry	Brick format [mm]	Mean compressive strength [N/mm ²]	Main country of origin	Mean gross density ρ [kg/dm ³]	Annex
Solid brick Mz					
Solid brick Mz	NF $\geq 240 \times 115 \times 71$	15 / 25 / 35	Germany	$\geq 1,8$	C4 – C7
Solid calcium silicate (sand- lime) brick KS / perforated calcium silicate (sand- lime) brick KSL					
Solid calcium silicate brick KS	NF $\geq 240 \times 115 \times 71$	15 / 25 / 35	Germany	$\geq 2,0$	C8 / C9
	$\geq 240 \times 115 \times 113$	12,5 / 25	Germany	$\geq 1,8$	C10 / C11
Perforated calcium silicate brick KSL	3DF 240x175x113	10 / 12,5 / 15 / 20 / 25	Germany	$\geq 1,4$	C12 – C14
Vertical perforated brick HLz					
Vertical perforated brick HLz	370x240x237	5 / 7,5 / 10 / 12,5 / 15	Germany	$\geq 1,0$	C15 / C16
	500x175x237	5 / 7,5 / 10 / 12,5 / 15	Germany	$\geq 1,0$	C15 / C16
	2DF 240x115x113	7,5 / 12,5 / 20 / 25 / 35	Germany	$\geq 1,4$	C17 / C18
	365x248x245	10	Austria	$\geq 0,6$	C19 – C20
	240x175x113	12,5	Germany	$\geq 0,9$	C21 / C22
Light-weight concrete hollow block Hbl					
Light-weight concrete hollow block Hbl	362x240x240	2,5 / 5	Germany	$\geq 1,0$	C23 / C24
Autoclaved aerated concrete (AAC)					
PP2 / AAC	-	2,5	Germany	0,35	C25 – C27
PP4 / AAC	-	5	Germany	0,5	C25 – C27
PP6 / AAC	-	8	Germany	0,65	C25 – C27
Injection system ULTRAPROFI for masonry					Annex B10
Intended Use Overview of assessed bricks					

Table B11.1: Overview dimensions of perforated and hollow bricks part 1

Perforated calcium silicate brick KSL, 3DF,
EN 771-2:2011+A1:2015; e.g. KS Wemding according to Annex C12

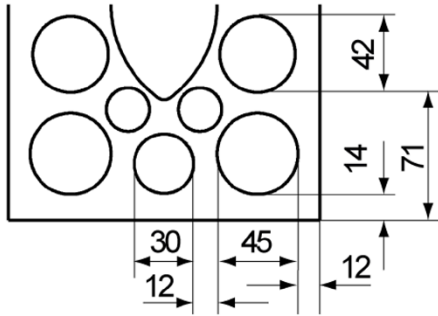

Vertical perforated brick HLz,
EN 771-1:2011+A1:2015; e.g. Wienerberger, Poroton according to Annex C15

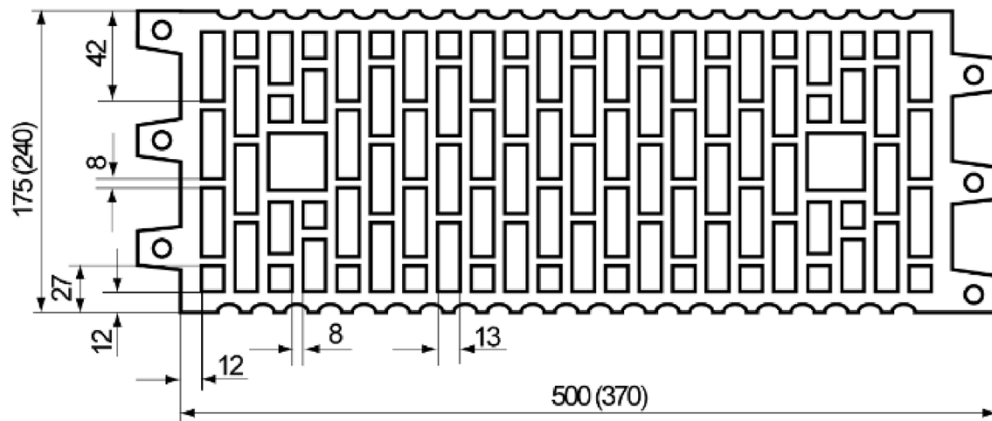

Vertical perforated brick HLz, 2DF,
EN 771-1:2011+A1:2015; e.g. Wienerberger according to Annex C17

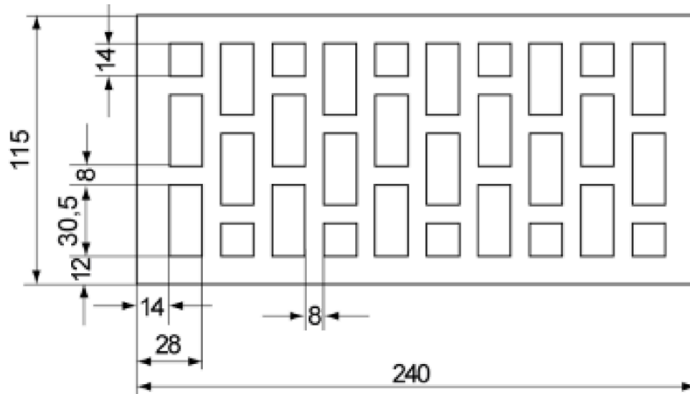

Measures in [mm]
Figures not to scale

Injection system ULTRAPROFI for masonry

Intended Use
Overview dimensions of perforated and hollow bricks part 1

Annex B11

Table B14.1: Overview dimensions of perforated and hollow bricks part 2

Vertical perforated brick filled with mineral wool,
EN 771-1:2011+A1:2015; according to Annex C19

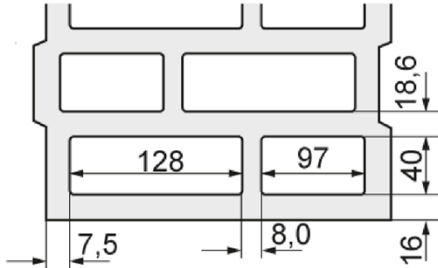

Vertical perforated brick HLz,
EN 771-1:2011+A1:2015; e.g. Wienerberger according to Annex C21

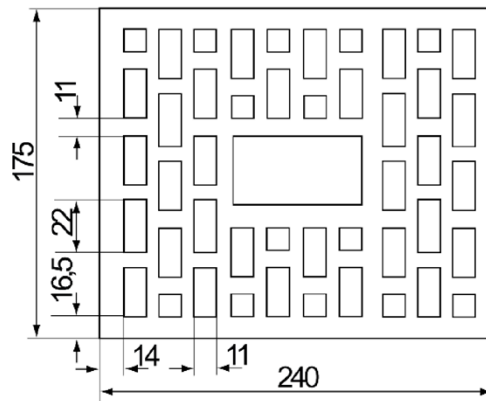

Light-weight concrete hollow block Hbl,
EN 771-3:2011+A1:2015; according to Annex C23

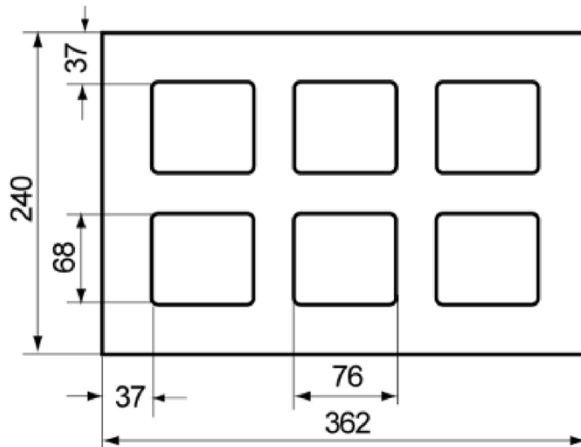

Measures in [mm]
Figures not to scale

Injection system ULTRAPROFI for masonry

Intended Use
Overview dimensions of perforated and hollow bricks part 2

Annex B12

Spacing and edge distance part 1

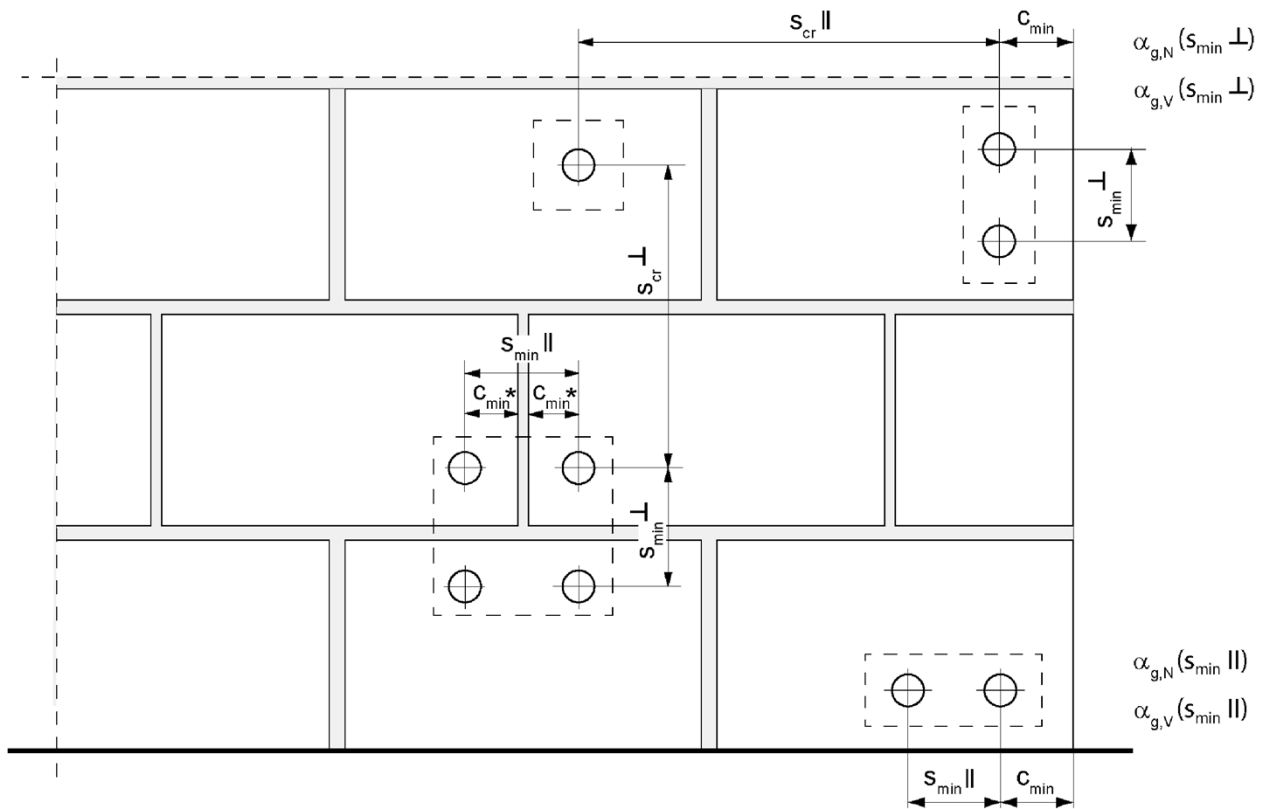

* Only, if vertical joints are not completely filled with mortar

$s_{min II}$	=	Minimum spacing parallel to horizontal joint
$s_{min \perp}$	=	Minimum spacing perpendicular to horizontal joint
$s_{cr II}$	=	Characteristic spacing parallel to horizontal joint
$s_{cr \perp}$	=	Characteristic spacing perpendicular to horizontal joint
$c_{cr} = c_{min}$	=	Edge distance
$\alpha_{g,N}(s_{min II})$	=	Group factor for tension load, anchor group parallel to horizontal joint
$\alpha_{g,V}(s_{min II})$	=	Group factor for shear load, anchor group parallel to horizontal joint
$\alpha_{g,N}(s_{min \perp})$	=	Group factor for tension load, anchor group perpendicular to horizontal joint
$\alpha_{g,V}(s_{min \perp})$	=	Group factor for shear load, anchor group perpendicular to horizontal joint

Figures not to scale

Injection system ULTRAPROFI for masonry

Intended Use
Spacing and edge distance part 1

Annex B13

Spacing and edge distance part 2

For $s \geq s_{cr}$: $\alpha_g = 2$

For $s_{min} \leq s < s_{cr}$: α_g according to installation parameters of brick Annex C

Group of 2 anchors

$$N_{Rk}^g = \alpha_{g,N} \cdot N_{Rk}; V_{Rk,b}^g = V_{Rk,c,II}^g = V_{Rk,c,\perp}^g = \alpha_{g,V} \cdot V_{Rk}$$

Group of 4 anchors

$$N_{Rk}^g = \alpha_{g,N}(s_{minII}) \cdot \alpha_{g,N}(s_{min\perp}) \cdot N_{Rk};$$

$$V_{Rk,b}^g = V_{Rk,c,II}^g = V_{Rk,c,\perp}^g = \alpha_{g,V}(s_{minII}) \cdot \alpha_{g,V}(s_{min\perp}) \cdot V_{Rk}$$

with N_{Rk} and $\alpha_{g,N}$ depending on s_{minII} or $s_{min\perp}$ acc. to Annex C

with V_{Rk} and $\alpha_{g,V}$ depending on s_{minII} or $s_{min\perp}$ acc. to Annex C

Injection system ULTRAPROFI for masonry

Intended Use
Spacing and edge distance part 2

Annex B14

Table C1.1: Characteristic resistance to steel failure under tension loading of anchor rods and standard threaded rods									
Anchor rod / standard threaded rod		M6	M8 ³⁾	M10 ³⁾	M12	M16			
Characteristic resistance to steel failure under tension loading									
Characteristic resistance $N_{Rk,s}$	Steel zinc plated	4.6	[kN]	8,0	14,6(13,2)	23,2(21,4)	33,7	62,8	
		4.8		8,0	14,6(13,2)	23,2(21,4)	33,7	62,8	
	Stainless steel R and High corrosion resistant steel HCR	5.8		10,0	18,3(16,6)	29,0(26,8)	42,1	78,5	
		8.8		16,0	29,2(26,5)	46,4(42,8)	67,4	125,6	
		Property class		50	10,0	18,3	29,0	42,1	78,5
				70	14,0	25,6	40,6	59,0	109,9
				80	16,0	29,2	46,4	67,4	125,6
Partial factors ¹⁾									
Partial factors $\gamma_{Ms,N}$	Steel zinc plated	4.6	[-]	2,00					
		4.8		1,50					
		5.8		1,50					
	Stainless steel R and High corrosion resistant steel HCR	8.8		1,50					
		Property class		50	2,86				
				70	1,50 ²⁾ / 1,87				
				80	1,60				
<p>1) In absence of other national regulations.</p> <p>2) Only for FIS A made of high corrosion resistant steel HCR.</p> <p>3) Values in brackets are valid for undersized threaded rods with smaller stress area A_s for hot-dip galvanised standard threaded rods according to EN ISO 10684:2004+AC:2009.</p>									
Injection system ULTRAPROFI for masonry						Annex C1			
Performance Characteristic resistance to steel failure under tension loading of anchor rods and standard threaded rods									

Table C2.1: Characteristic resistance to steel failure under shear loading of anchor rods and standard threaded rods								
Anchor rod / standard threaded rod		M6	M8 ³⁾	M10 ³⁾	M12	M16		
Characteristic resistance to steel failure under shear loading								
without lever arm								
Characteristic resistance $V_{Rk,s}$	Steel zinc plated	4.6	[kN]	4,8	8,7(7,9)	13,9(12,8)	20,2	37,6
		4.8		4,8	8,7(7,9)	13,9(12,8)	20,2	37,6
	Property class	5.8		6,0	10,9(9,9)	17,4(16,0)	25,2	47,1
		8.8		8,0	14,6(13,2)	23,2(21,4)	33,7	62,8
		Stainless steel R and High corrosion resistant steel HCR		50	5,0	9,1	14,5	21,0
	70			7,0	12,8	20,3	29,5	54,9
	80	8,0		14,6	23,2	33,7	62,8	
with lever arm								
Characteristic resistance $M^0_{Rk,s}$	Steel zinc plated	4.6	[Nm]	6,1	14,9(12,9)	29,9(26,5)	52,3	132,9
		4.8		6,1	14,9(12,9)	29,9(26,5)	52,3	132,9
	Property class	5.8		7,6	18,7(16,1)	37,3(33,2)	65,4	166,2
		8.8		12,2	29,9(25,9)	59,8(53,1)	104,6	265,9
		Stainless steel R and High corrosion resistant steel HCR		50	7,6	18,7	37,3	65,4
	70			10,6	26,2	52,3	91,5	232,6
	80	12,2		29,9	59,8	104,6	265,9	
Partial factors¹⁾								
Partial factors $\gamma_{Ms,V}$	Steel zinc plated	4.6	[-]	1,67				
		4.8		1,25				
	Property class	5.8		1,25				
		8.8		1,25				
		Stainless steel R and High corrosion resistant steel HCR		50	2,38			
	70			1,25 ²⁾ / 1,56				
	80	1,33						
<p>1) In absence of other national regulations</p> <p>2) Only for FIS A made of high corrosion resistant steel HCR</p> <p>3) Values in brackets are valid for undersized threaded rods with smaller stress area A_s for hot-dip galvanised standard threaded rods (M8 resp. M10) according to EN ISO 10684:2004+AC:2009.</p>								
Injection system ULTRAPROFI for masonry						Annex C2		
Performance Characteristic resistance to steel failure under shear loading of anchor rods and standard threaded rods								

Table C3.1: Characteristic resistance to steel failure under tension / shear loading of internal threaded anchors FIS E								
Internal threaded anchor FIS E				M6	M8	M10	M12	
Characteristic resistance to steel failure under tension loading, decisive values of internal threaded anchor FIS E with screw/threaded rod								
Characteristic resistance	$N_{Rk,s}$	Property class 4.6	[kN]	8,0	14,6	23,2	33,7	
		Property class 5.8		10,0	18,3	29,0	42,1	
		Property class 70		R	14,0	25,6	40,6	59,0
		HCR		14,0	25,6	40,6	59,0	
Partial factors¹⁾								
Partial factors	$\gamma_{Ms,N}$	Property class 4.6	[-]	2,00				
		Property class 5.8		1,50				
		Property class 70		R	1,87			
		HCR		1,87				
Characteristic resistance to steel failure under shear loading; decisive values of internal threaded anchor FIS E with screw/threaded rod								
without lever arm								
Characteristic resistance	$V_{Rk,s}$	Property class 4.6	[kN]	4,8	8,7	13,9	20,2	
		Property class 5.8		6,0	10,9	15,0	21,0	
		Property class 70		R	7,0	12,8	20,3	29,5
		HCR		7,0	12,8	20,3	29,5	
with lever arm								
Characteristic resistance	$M^0_{Rk,s}$	Property class 4.6	[Nm]	6,1	14,9	29,9	52,3	
		Property class 5.8		7,6	18,7	37,3	65,4	
		Property class 70		R	10,6	26,2	52,3	91,5
		HCR		10,6	26,2	52,3	91,5	
Partial factors¹⁾								
Partial factors	$\gamma_{Ms,V}$	Property class 4.6	[-]	1,67				
		Property class 5.8		1,25				
		Property class 70		R	1,56			
		HCR		1,56				
1) In absence of other national regulations								
Injection system ULTRAPROFI for masonry						Annex C3		
Performance Characteristic resistance to steel failure under tension / shear loading of internal threaded anchors FIS E								

Solid brick Mz, NF, EN 771-1:2011+A1:2015

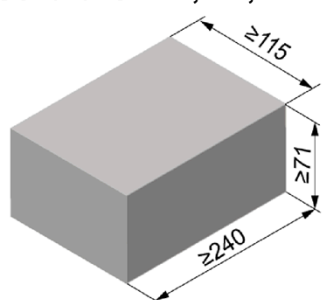

Producer	e.g. Wienerberger			
Nominal dimensions	[mm]	length L	width W	height H
		≥ 240	≥ 115	≥ 71
Mean gross dry density ρ	[kg/dm ³]	≥ 1,8		
Mean compressive strength / Min. compressive strength single brick ¹⁾	[N/mm ²]	15 / 12 or 25 / 20 or 35 / 28		
Standard or annex	EN 771-1:2011+A1:2015			

Table C4.1: Installation parameters for edge distance $c=100\text{mm}$

Anchor rod		M6	M8	M10	M12	-		-		
Internal threaded anchor FIS E		-	-	-	-	M6	M8	M10	M12	
						11x85		15x85		
Anchor rod and internal threaded anchor FIS E without perforated sleeve										
Effective anchorage depth	h_{ef}	[mm]	50	50	50	50	85			
			80	80	80	80				
			200	200	200	200				
Max. installation torque	$\max T_{inst}$	[Nm]	4	10			4	10		
General installation parameters										
Edge distance	$c_{min} = c_{cr}$	[mm]	100				100			
Edge distance $h_{ef}=200$	$c_{min} = c_{cr}$		150				- ²⁾			
Spacing	$s_{min II,N}$		60				60			
	$h_{ef}=200 s_{min II,N}$		240				- ²⁾			
	$s_{min II,V}$		240				240			
	$s_{cr II}$		240				240			
	$s_{cr \perp} = s_{min \perp}$		75				75			

Drilling method

Hammer drilling with hard metal hammer drill

¹⁾ The minimum compressive strength of the single brick must not be less than 80% of the mean compressive strength.

²⁾ No performance assessed

Table C4.2: Group factors

Anchor rods		M6	M8	M10	M12	-		-	
Internal threaded anchor FIS E		-	-	-	-	M6	M8	M10	M12
						11x85		15x85	
Edge distance	c_{min}	[mm]		100					
Group factor	$\alpha_{a,N} (s_{min II})$	[-]		1,5					
	$\alpha_{g,V} (s_{min II})$			2,0					
	$h_{ef}=200 \alpha_{a,N} (s_{min II})$			1,5					
	$h_{ef}=200 \alpha_{g,V} (s_{min II})$			2,0					
	$\alpha_{a,N} (s_{min \perp})$			2,0					
	$\alpha_{g,V} (s_{min \perp})$			2,0					
	$h_{ef}=200 \alpha_{a,N} (s_{min \perp})$			2,0					
	$h_{ef}=200 \alpha_{g,V} (s_{min \perp})$			2,0					

Injection system ULTRAPROFI for masonry

Performance

Solid brick Mz, NF, dimensions, installation parameters for edge distance $c=100\text{mm}$, Group factors

Annex C4

Solid brick Mz, NF, EN 771-1:2011+A1:2015

Table C5.1: Characteristic resistance to pull-out failure or brick breakout failure of a single anchor under tension loading for edge distance $c=100\text{mm}$

Anchor rod	M6	M8	M10	M12	-		-	
Internal threaded anchor FIS E	-	-	-	-	M6	M8	M10	M12
					11x85		15x85	

$N_{Rk} = N_{Rk,p} = N_{Rk,b} = N_{Rk,p,c} = N_{Rk,b,c}$ [kN]; temperature range 50/80°C ²⁾

Mean compressive strength / Min. compressive strength single brick ¹⁾	Use conditions	Effective anchorage depth h_{ef} [mm]								
		≥50	≥50	50	80	200	50	80	200	85
15 / 12 N/mm ²	w/w w/d	2,5	2,5	2,0	3,0	7,5	2,0	3,5	5,0	3,5
	d/d	4,0	4,0	3,5	5,0	12,0	3,0	5,5	8,0	5,5
25 / 20 N/mm ²	w/w w/d	3,5	3,5	3,0	4,5	11,0	3,0	5,0	7,0	5,0
	d/d	5,5	5,5	5,0	7,0	12,0	4,5	8,0	11,5	8,0

¹⁾ The minimum compressive strength of the single brick must not be less than 80% of the mean compressive strength.

²⁾ For temperature range 72/120°C: $N_{Rk(72/120^\circ\text{C})} = 0,83 \cdot N_{Rk(50/80^\circ\text{C})}$.

Table C5.2: Characteristic resistance to local brick failure or brick edge failure of a single anchor under shear loading for edge distance $c=100\text{mm}$

Anchor rod	M6	M8	M10	M12	-		-	
Internal threaded anchor FIS E	-	-	-	-	M6	M8	M10	M12
					11x85		15x85	

$V_{Rk} = V_{Rk,b} = V_{Rk,c,II} = V_{Rk,c,\perp}$ [kN]; temperature range 50/80°C and 72/120°C

Mean compressive strength / Min. compressive strength single brick ¹⁾	Use conditions	Effective anchorage depth h_{ef} [mm]						85
		≥50	≥50	≥50	200	≥50	200	
15 / 12 N/mm ²	w/w w/d	2,5	2,5	4,0	8,5	4,0	11,5	2,5
	d/d	4,0	4,0	6,0	12,0	5,5	12,0	4,0

¹⁾ The minimum compressive strength of the single brick must not be less than 80% of the mean compressive strength.

Factor for job site tests and displacements see annex C28.

Injection system ULTRAPROFI for masonry

Performance

Solid brick Mz, NF, Characteristic resistance under tension and shear loading, edge distance $c=100\text{mm}$

Annex C5

Solid brick Mz, NF, EN 771-1:2011+A1:2015

Table C6.1: Installation parameters for edge distance $c=60\text{mm}$

Anchor rod		M6	M8	M10	M12	M16	-	-
Internal threaded anchor FIS E		-	-	-	-	-	M6	M8
							11x85	15x85
Anchor rod and internal threaded anchor FIS E without perforated sleeve								
Effective anchorage depth h_{ef}	[mm]	50	50	50	50	50	85	
		100	100	100	100	100		
		200	200	200	200	200		
Max. installation torque $\max T_{inst}$	[Nm]	4	10				4	10

General installation parameters

Edge distance $c_{min} = c_{cr}$		60
Edge distance $h_{ef}=200$	c_{min}	60
Spacing	$s_{min \parallel, N}$	80
	$h_{ef}=200$ $s_{min \parallel, N}$	80
	$s_{min \parallel, V}$	80
	$s_{cr \parallel}$	$3x h_{ef}$
	$s_{min \perp}$	80
	$s_{cr \perp}$	$3x h_{ef}$

Drilling method

Hammer drilling with hard metal hammer drill

Table C6.2: Group factors

Anchor rods		M6	M8	M10	M12	M16	-	-		
Internal threaded anchor FIS E		-	-	-	-	-	M6	M8		
							11x85	15x85		
Edge distance c_{min}	[mm]	60								
Group factor	$\alpha_{g, N} (s_{min \parallel})$	[-]	0,6							
	$\alpha_{g, V} (s_{min \parallel})$		1,3							
	$h_{ef}=200$ $\alpha_{g, N} (s_{min \parallel})$		1,4							
	$h_{ef}=200$ $\alpha_{g, V} (s_{min \parallel})$		1,5							
	$\alpha_{g, N} (s_{min \perp})$		0,3							
	$\alpha_{g, V} (s_{min \perp})$		1,3							
	$h_{ef}=200$ $\alpha_{g, N} (s_{min \perp})$		2,0							
	$h_{ef}=200$ $\alpha_{g, V} (s_{min \perp})$		1,1							

Injection system ULTRAPROFI for masonry

Performance

Solid brick Mz, NF, dimensions, installation parameters, edge distance $c=60\text{mm}$, Group factors

Annex C6

Solid brick Mz, NF, EN 771-1:2011+A1:2015

Table C7.1: Characteristic resistance to pull-out failure or brick breakout failure of a single anchor under tension loading for edge distance $c=60\text{mm}$

Anchor rod	M6	M8	M10	M12	M16	-	-		
Internal threaded anchor FIS E	-	-	-	-	-	M6	M8	M10	M12
	11x85		15x85						

$N_{Rk} = N_{Rk,p} = N_{Rk,b} = N_{Rk,p,c} = N_{Rk,b,c}$ [kN]; temperature range 50/80°C³⁾

Mean compressive strength / Min. compressive strength single brick ¹⁾	Use conditions		Effective anchorage depth h_{ef} [mm]												85
			50	100	50	100	50	100	200	50	100	200	50	100	
15 / 12 N/mm ²	w/w	w/d	1,5	2,0	2,0	2,0	2,5	- ²⁾	2,0	2,5	- ²⁾	2,0	5,5	- ²⁾	- ²⁾
	d/d		2,5	3,0	4,0	3,0	4,0	9,5	3,0	4,0	9,5	3,0	8,5	9,5	- ²⁾
25 / 20 N/mm ²	w/w	w/d	2,0	2,5	3,0	2,5	3,5	- ²⁾	3,0	3,5	- ²⁾	3,0	7,5	- ²⁾	- ²⁾
	d/d		3,5	4,5	5,5	4,5	5,5	12	4,5	5,5	12	4,5	12	12	- ²⁾
35 / 28 N/mm ²	w/w	w/d	2,5	3,0	4,0	3,0	4,0	- ²⁾	3,5	4,0	- ²⁾	3,5	9,0	- ²⁾	- ²⁾
	d/d		4,0	5,5	6,5	5,5	6,5	12	5,5	6,5	12	5,5	12	12	- ²⁾

- ¹⁾ The minimum compressive strength of the single brick must not be less than 80% of the mean compressive strength.
²⁾ No performance assessed.
³⁾ For temperature range 72/120°C: $N_{Rk(72/120^\circ\text{C})} = 0,83 \cdot N_{Rk(50/80^\circ\text{C})}$.

Table C7.2: Characteristic resistance to local brick failure or brick edge failure of a single anchor under shear loading for edge distance $c=60\text{mm}$

Anchor rod	M6	M8	M10	M12	M16	-	-		
Internal threaded anchor FIS E	-	-	-	-	-	M6	M8	M10	M12
	11x85		15x85						

$V_{Rk} = V_{Rk,b} = V_{Rk,c,II} = V_{Rk,c,I}$ [kN]; temperature range 50/80°C and 72/120°C

Mean compressive strength / Min. compressive strength single brick ¹⁾	Use conditions		Effective anchorage depth h_{ef} [mm]												85	
			50	100	50	100	50	100	200	50	100	200	50	100		200
15 / 12 N/mm ²	w/w w/d d/d		1,2	2,5	1,2	3,0	2,0	3,0	1,5	1,5	3,0	3,0	0,6	3,0	4,5	- ²⁾
25 / 20 N/mm ²			1,5	3,5	1,5	4,5	3,0	4,5	2,5	2,0	4,5	4,5	0,9	4,5	6,0	- ²⁾
35 / 28 N/mm ²			2,0	4,0	2,0	5,0	3,5	5,0	3,0	2,5	5,0	5,0	1,2	5,0	7,5	- ²⁾

- ¹⁾ The minimum compressive strength of the single brick must not be less than 80% of the mean compressive strength.
²⁾ No performance assessed.

Factor for job site tests and displacements see annex C28.

Injection system ULTRAPROFI for masonry	Annex C7
Performance Solid brick Mz, NF, Characteristic resistance under tension and shear loading, edge distance $c=60\text{mm}$	

Solid calcium silicate brick KS, NF, EN 771-2:2011+A1:2015

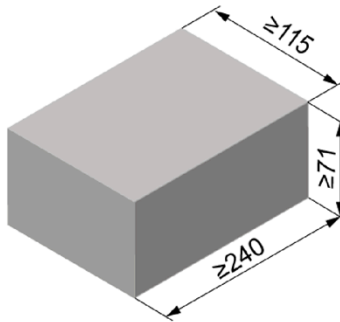

Producer	-			
Nominal dimensions	[mm]	length L	width W	height H
		≥ 240	≥ 115	≥ 71
Mean gross dry density ρ	[kg/dm ³]	≥ 1,8		
Mean compressive strength / Min. compressive strength single brick ¹⁾	[N/mm ²]	15 / 12 or 25 / 20 or 35 / 28		
Standard or annex	EN 771-2:2011+A1:2015			

Table C8.1: Installation parameters

Anchor rod	M6	M8	M10	M12	M16	-	-							
Internal threaded anchor FIS E	-	-	-	-	-	M6	M8	M10	M12					
						11x85	15x85							
Anchor rod and internal threaded anchor FIS E without perforated sleeve														
Effective anchorage depth h_{ef}	[mm]	50	100	50	100	50	100	50	100	50	100	85	85	
						200		200		200				
Max. installation torque $\max T_{inst}$	[Nm]	3		5		15		15		25		3	5	15
General installation parameters														
Edge distance $c_{min} = c_{cr}$								60						
Spacing	$s_{min \parallel}$							80						
	$s_{cr \parallel}$							80						
	$s_{min \perp}$							3x h_{ef}						
	$s_{cr \perp}$							3x h_{ef}						
Drilling method														
Hammer drilling with hard metal hammer drill														

¹⁾ The minimum compressive strength of the single brick must not be less than 80% of the mean compressive strength..

Table C8.2: Group factors

Anchor rod	M6	M8	M10	M12	M16	-	-				
Internal threaded anchor FIS E	-	-	-	-	-	M6	M8	M10	M12		
						11x85	15x85				
Group factor	$\alpha_{g,N} (s_{min \parallel})$							0,7			
	$\alpha_{g,V} (s_{min \parallel})$							1,3			
	$\alpha_{g,N} (s_{min \perp})$							2,0			
	$\alpha_{g,V} (s_{min \perp})$							2,0			

Injection system ULTRAPROFI for masonry

Performance

Solid calcium silicate brick KS, NF, dimensions, installation parameters, Group factors

Annex C8

Solid calcium silicate brick KS, NF, EN 771-2:2011+A1:2015

Table C9.1: Characteristic resistance to pull-out failure or brick breakout failure of a single anchor under tension loading

Anchor rod		M6		M8		M10			M12			M16			-		-	
Internal threaded anchor FIS E		-		-		-			-			-			M6	M8	M10	M12
															11x85		15x85	
$N_{Rk} = N_{Rk,p} = N_{Rk,b} = N_{Rk,p,c} = N_{Rk,b,c}$ [kN]; temperature range 50/80°C ²⁾																		
Mean compressive strength / Min. compressive strength single brick ¹⁾	Use conditions		Effective anchorage depth h_{ef} [mm]															
			50	100	50	100	50	100	200	50	100	200	50	100	200	85	85	
15 / 12 N/mm²	w/w	w/d	2,0	3,0	2,5	4,5	2,5	3,5	7,0	2,5	3,0	6,5	2,5	3,5	8,0	2,5	2,5	
	d/d		4,0	5,5	4,0	8,0	4,0	5,5	12	4,0	4,5	12	4,5	5,5	12	4,0	4,0	
25 / 20 N/mm²	w/w	w/d	3,0	4,5	3,5	6,5	3,5	4,5	10	3,5	4,0	9,5	4,0	5,0	11	3,5	3,5	
	d/d		5,5	7,5	6,0	11	6,0	8,0	12	6,0	6,5	12	6,5	8,0	12	6,0	6,0	
35 / 28 N/mm²	w/w	w/d	3,5	5,0	4,0	8,0	4,5	5,5	12	4,5	5,0	11	4,5	5,5	12	4,5	4,5	
	d/d		6,5	9,0	7,0	12	7,0	9,0	12	7,0	7,5	12	7,5	9,5	12	7,0	7,0	

¹⁾ The minimum compressive strength of the single brick must not be less than 80% of the mean compressive strength.

²⁾ For temperature range 72/120°C: $N_{Rk(72/120°C)} = 0,83 \cdot N_{Rk(50/80°C)}$.

Table C9.2: Characteristic resistance to local brick failure or brick edge failure of a single anchor under shear loading

Anchor rod		M6		M8		M10			M12			M16			-		-	
Internal threaded anchor FIS E		-		-		-			-			-			M6	M8	M10	M12
															11x85		15x85	
$V_{Rk} = V_{Rk,b} = V_{Rk,c,II} = V_{Rk,c,L}$ [kN]; temperature range 50/80°C and 72/120°C																		
Mean compressive strength / Min. compressive strength single brick ¹⁾	Use conditions		Effective anchorage depth h_{ef} [mm]															
			50	100	50	100	50	≥100	50	≥100	50	≥100	85	85				
15 / 12 N/mm²	w/w	w/d	1,5	3,0	1,5	3,0	1,2	2,0	1,2	2,0	1,2	2,0	1,2	1,2				
	d/d																	
25 / 20 N/mm²	w/w	w/d	2,5	4,0	2,5	4,0	1,5	3,0	1,5	3,0	1,5	3,0	1,5	1,5				
	d/d																	
35 / 28 N/mm²	w/w	w/d	3,0	4,5	3,0	4,5	1,5	3,5	1,5	3,5	1,5	3,5	1,5	1,5				
	d/d																	

¹⁾ The minimum compressive strength of the single brick must not be less than 80% of the mean compressive strength.

Factor for job site tests and displacements see annex C28.

Injection system ULTRAPROFI for masonry

Performance

Solid calcium silicate brick KS, NF, Characteristic resistance under tension and shear loading

Annex C9

Solid calcium silicate brick KS, EN 771-2:2011+A1:2015

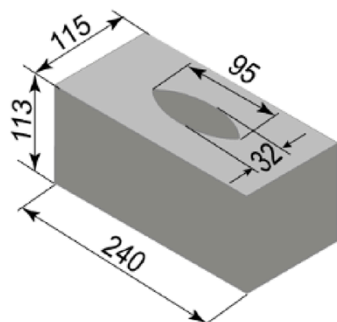

Producer	-			
Nominal dimensions	[mm]	length L	width W	height H
		≥ 240	≥ 115	≥ 113
Mean gross dry density ρ	[kg/dm ³]	1,8		
Mean compressive strength / Min. compressive strength single brick ¹⁾	[N/mm ²]	12,5 / 10 or 25 / 20		
Standard or annex	EN 771-2:2011+A1:2015			

Table C10.1: Installation parameters
(Pre-positioned installation with perforated sleeve FIS H K)

Anchor rod	M6	M8	-	M8	M10	M8	M10	-	M12	M16	M12	M16
Internal threaded anchor FIS E	-		M6 M8	-		-		M10 M12	-		-	
			11x85					15x85				
Perforated sleeve FIS H K	12x85		16x85		16x130		20x85		20x130			
Anchor rod and internal threaded anchor FIS E with perforated sleeve FIS H K												
Max. installation torque	max T _{inst} [Nm]	2		4								
General installation parameters												
Edge distance	C _{min} = C _{cr}	100										
Spacing	S _{min}	[mm]	255	255	390	255	390					
	S _{cr}											
	S _{min} ⊥											
	S _{cr} ⊥											
Drilling method												
Hammer drilling with hard metal hammer drill												
¹⁾ The minimum compressive strength of the single brick must not be less than 80% of the mean compressive strength.												
Table C10.2: Group factors												
Anchor rod	M6	M8	M8	M10	M8	M10	M12	M16	M12	M16		
Perforated sleeve FIS H K	12x85		16x85		16x130		20x85		20x130			
Group factors	$\frac{\alpha_{g,N}(S_{min \parallel})}{\alpha_{g,V}(S_{min \parallel})}$ $\frac{\alpha_{g,N}(S_{min \perp})}{\alpha_{g,V}(S_{min \perp})}$		[-]		2,0							
Injection system ULTRAPROFI for masonry											Annex C10	
Performance Solid calcium silicate brick KS, dimensions, installation parameters, Group factors												

Solid calcium silicate brick KS, EN 771-2:2011+A1:2015

Table C11.1: Characteristic resistance to pull-out failure or brick breakout failure of a single anchor under tension loading

Anchor rod	M6	M8	-	M8	M10	M8	M10	-	M12	M16	M12	M16
Internal threaded anchor FIS E	-	M6	M8	-	-	-	-	M10	M12	-	-	-
		11x85						15x85				
Perforated sleeve FIS H K	12x85		16x85			16x130		20x85			20x130	

$N_{RK} = N_{RK,p} = N_{RK,b} = N_{RK,p,c} = N_{RK,b,c}$ [kN]; temperature range 50/80°C²⁾

Mean compressive strength / Min. compressive strength single brick ¹⁾	Use conditions										
12,5 / 10 N/mm ²	w/w	3,5	2,0	2,0	2,0	6,5				4,5	
	d/d	6,0	4,0	3,5	3,5	10,5				7,0	
25 / 20 N/mm ²	w/w	5,0	3,0	3,0	3,0	9,5				6,0	
	d/d	8,5	5,5	5,5	5,5	12,0				10,0	

¹⁾ The minimum compressive strength of the single brick must not be less than 80% of the mean compressive strength.

²⁾ For temperature range 72/120°C no performance assessed.

Table C11.2: Characteristic resistance to local brick failure or brick edge failure of a single anchor under shear loading

Anchor rod	M6	M8	-	M8	M10	M8	M10	-	M12	M16	M12	M16
Internal threaded anchor FIS E	-	M6	M8	-	-	-	-	M10	M12	-	-	-
		11x85						15x85				
Perforated sleeve FIS H K	12x85		16x85			16x130		20x85			20x130	

$V_{RK} = V_{RK,b} = V_{RK,c,II} = V_{RK,c,I}$ [kN]; temperature range 50/80°C²⁾

Mean compressive strength / Min. compressive strength single brick ¹⁾	Use conditions										
12,5 / 10 N/mm ²	w/w	3,0	3,5								
	d/d										
25 / 20 N/mm ²	w/w	4,0	5,5								
	d/d										

¹⁾ The minimum compressive strength of the single brick must not be less than 80% of the mean compressive strength.

²⁾ For temperature range 72/120°C no performance assessed.

Factor for job site tests and displacements see annex C28.

Injection system ULTRAPROFI for masonry

Performance

Solid calcium silicate brick KS, Characteristic resistance under tension loading and shear loading

Annex C11

Perforated calcium silicate brick KSL, 3DF, EN 771-2:2011+A1:2015

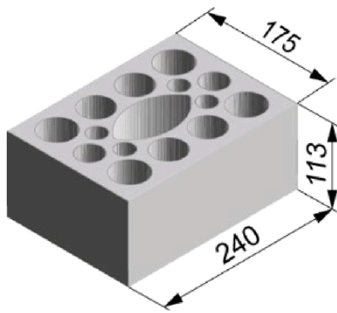

Producer	-			
Nominal dimensions	[mm]	length L	width W	height H
		240	175	113
Mean gross dry density ρ	[kg/dm ³]	$\geq 1,4$		
Mean compressive strength / Min. compressive strength single brick ¹⁾	[N/mm ²]	10 / 8 or 12,5 / 10 or 15 / 12 or 20 / 16 or 25 / 20		
Standard or annex	EN 771-2:2011+A1:2015			

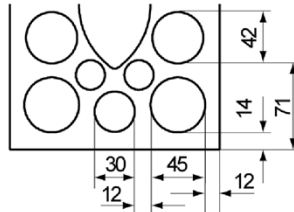

Dimension see also Annex B11

Table C12.1: Installation parameters
(Pre-positioned installation with perforated sleeve FIS H K)

Anchor rod	M6	M8	M6	M8	-	M8	M10	M8	M10	-	M12	M16	M12	M16	
Internal threaded anchor FIS E	-		-		M6	M8	-		-		M10	M12	-		
					11x85						15x85				
Perforated sleeve FIS H K	12x50		12x85		16x85			16x130		20x85			20x130		
Anchor rod and internal threaded anchor FIS E with perforated sleeve FIS H K															
Max. installation torque	max T _{inst}	[Nm]	2												
General installation parameters															
Edge distance	C _{min} = C _{cr}		60				80								
Spacing	S _{min}	[mm]	100												
	S _{cr}		240												
	S _{min} ⊥		115												
	S _{cr} ⊥		115												
Drilling method															
Hammer drilling with hard metal hammer drill															
¹⁾ The minimum compressive strength of the single brick must not be less than 80% of the mean compressive strength.															
Table C12.2: Group factors															
Anchor rod	M6	M8	M6	M8	-	M8	M10	M8	M10	-	M12	M16	M12	M16	
Internal threaded anchor FIS E	-		-		M6	M8	-		-		M10	M12	-		
					11x85						15x85				
Perforated sleeve FIS H K	12x50		12x85		16x85			16x130		20x85			20x130		
Group factors	$\frac{\alpha_{g,N}(S_{min})}{\alpha_{g,V}(S_{min})}$	[-]	1,5												
	$\frac{\alpha_{g,N}(S_{min} \perp)}{\alpha_{g,V}(S_{min} \perp)}$		2,0												
Injection system ULTRAPROFI for masonry											Annex C12				
Performance Perforated calcium silicate brick KSL, 3DF, dimensions, installation parameters, Group factors															

Perforated calcium silicate brick KSL, 3DF, EN 771-2:2011+A1:2015

Table C13.1: Characteristic resistance to pull-out failure or brick breakout failure of a single anchor under tension loading

Anchor rod	M6	M8	M6	M8	-	M8	M10	M8	M10	-	M12	M16	M12	M16
Internal threaded anchor FIS E	-	-	M6	M8	11x85	-	-	-	-	M10	M12	15x85	-	-
Perforated sleeve FIS H K	12x50	12x85	16x85			16x130			20x85			20x130		

$N_{Rk} = N_{Rk,p} = N_{Rk,b} = N_{Rk,p,c} = N_{Rk,b,c}$ [kN]; temperature range 50/80°C ²⁾

Mean compressive strength/ Min. comp. strength single brick ¹⁾	Use conditions									
	w/w	w/d								
10 / 8 N/mm²	w/w	w/d	1,5	2,0	2,0	2,0	2,0	2,0	2,0	2,0
	d/d		1,5	2,0	2,5	2,5	2,5	2,5	2,5	2,5
12,5 / 10 N/mm²	w/w	w/d	2,0	2,0	2,5	2,5	2,5	2,5	2,5	2,5
	d/d		2,0	2,5	3,0	3,0	3,0	3,0	3,0	3,0
15 / 12 N/mm²	w/w	w/d	2,5	2,5	3,0	3,0	3,0	3,0	3,0	3,0
	d/d		2,5	3,0	3,5	3,5	3,5	3,5	3,5	3,5
20 / 16 N/mm²	w/w	w/d	3,0	3,5	4,5	4,5	4,5	4,5	4,5	4,5
	d/d		3,5	4,0	4,5	4,5	4,5	4,5	4,5	4,5
25 / 20 N/mm²	w/w	w/d	4,0	4,5	5,5	5,5	5,5	5,5	5,5	5,5
	d/d		4,5	5,0	6,0	6,0	6,0	6,0	6,0	6,0

¹⁾ The minimum compressive strength of the single brick must not be less than 80% of the mean compressive strength.

²⁾ For temperature range 72/120°C: $N_{Rk(72/120°C)} = 0,83 \cdot N_{Rk(50/80°C)}$.

Factor for job site tests and displacements see annex C28.

Injection system ULTRAPROFI for masonry

Performance

Perforated calcium silicate brick KSL, 3DF, Characteristic resistance under tension loading

Annex C13

Perforated calcium silicate brick KSL, 3DF, EN 771-2:2011+A1:2015

Table C14.1: Characteristic resistance to local brick failure or brick edge failure of a single anchor under shear loading

Anchor rod	M6	M8	M6	M8	-	M8	M10	M8	M10	-	M12	M16	M12	M16
Internal threaded anchor FIS E	-		-		M6	M8	-		-		M10	M12	-	
					11x85						15x85			
Perforated sleeve FIS H K	12x50		12x85		16x85			16x130		20x85			20x130	

$V_{RK} = V_{RK,b} = V_{RK,c,II} = V_{RK,c,\perp}$ [kN]; temperature range 50/80°C and 72/120°C

Mean compressive strength / Min. compressive strength single brick ¹⁾	Use conditions																
	10 / 8 N/mm ²	w/w	w/d	1,5						3,0						2,5	3,0
d/d																	
12,5 / 10 N/mm ²	w/w	w/d	2,0						3,5								
	d/d																
15 / 12 N/mm ²	w/w	w/d	2,5						4,5						4,0	4,5	4,0
	d/d																
20 / 16 N/mm ²	w/w	w/d	3,0	3,5	3,0	3,5	3,0	6,0						5,5	6,0	5,5	
	d/d																
25 / 20 N/mm ²	w/w	w/d	4,0	4,5	4,0	4,5	4,0	7,5						6,5	7,5	6,5	
	d/d																

¹⁾ The minimum compressive strength of the single brick must not be less than 80% of the mean compressive strength.

Factor for job site tests and displacements see annex C28.

Injection system ULTRAPROFI for masonry

Performance

Perforated calcium silicate brick KSL, 3DF, Characteristic resistance under shear loading

Annex C14

Vertical perforated brick HLz, EN 771-1:2011+A1:2015

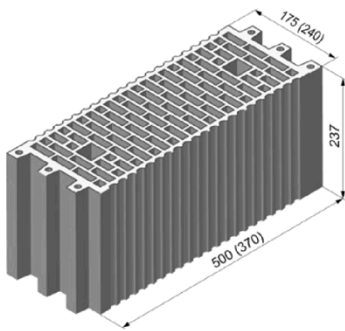

Producer	e.g. Wienerberger, Poroton			
Nominal dimensions	[mm]	length L	width W	height H
		500	175	237
		370	240	237
Mean gross dry density ρ	[kg/dm ³]	≥ 1,0		
Mean compressive strength / Min. compressive strength single brick ¹⁾	[N/mm ²]	5 / 4 or 7,5 / 6 or 10 / 8 or 12,5 / 10 or 15 / 12		
Standard or annex	EN 771-1:2011+A1:2015			

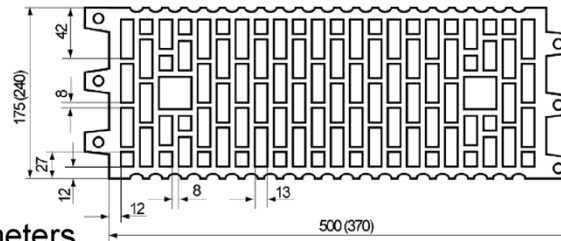

Dimension see also Annex B11

Table C15.1: Installation parameters

Anchor rod	M6	M8	M6	M8	-	M8	M10	M8	M10	-	M12	M16	M12	M16
Internal threaded anchor FIS E	-		-		M6	M8	-		-		M10	M12	-	
					11x85						15x85			
Perforated sleeve FIS H K	12x50		12x85		16x85			16x130		20x85			20x130	
Anchor rod and internal threaded anchor FIS E with perforated sleeve FIS H K														
Max. installation torque	max T _{inst}	[Nm]	2											
General installation parameters														
Edge distance	C _{min} = C _{cr}		100											
Spacing	S _{min}	[mm]	100											
	S _{cr}		500 (370)											
	S _{min} ⊥		100											
	S _{cr} ⊥		240											
Drilling method														
Hammer drilling with hard metal hammer drill														
¹⁾ The minimum compressive strength of the single brick must not be less than 80% of the mean compressive strength.														
Table C15.2: Group factors														
Anchor rod	M6	M8	M6	M8	-	M8	M10	M8	M10	-	M12	M16	M12	M16
Internal threaded anchor FIS E	-		-		M6	M8	-		-		M10	M12	-	
					11x85						15x85			
Perforated sleeve FIS H K	12x50		12x85		16x85			16x130		20x85			20x130	
Group factors	$\alpha_{g,N} (S_{min}) =$ $\alpha_{g,V} (S_{min}) =$ $\alpha_{g,N} (S_{min} \perp) =$ $\alpha_{g,V} (S_{min} \perp) =$	[-]	1,0											
Injection system ULTRAPROFI for masonry														
Performance Vertical perforated brick HLz, dimensions, installation parameters, Group factors														
Annex C15														

Vertical perforated brick HLz, EN 771-1:2011+A1:2015

Table C16.1: Characteristic resistance to pull-out failure or brick breakout failure of a single anchor under tension loading

Anchor rod	M6	M8	M6	M8	-	M8	M10	M8	M10	-	M12	M16	M12	M16
Internal threaded anchor FIS E	-	-	M6	M8	11x85	-	-	-	-	M10	M12	-	-	-
Perforated sleeve FIS H K	12x50	12x85	16x85			16x130			20x85			20x130		
$N_{RK} = N_{RK,p} = N_{RK,b} = N_{RK,p,c} = N_{RK,b,c}$ [kN]; temperature range 50/80°C²⁾														
Mean compressive strength / Min. comp. strength single brick ¹⁾	Use conditions													
5 / 4 N/mm²	w/w	w/d	0,30			0,90			1,20					
	d/d		0,40			0,90			1,20					
7,5 / 6 N/mm²	w/w	w/d	0,50			1,50			2,00					
	d/d		0,60			1,50			2,00					
10 / 8 N/mm²	w/w	w/d	0,75			2,00			2,50					
	d/d		0,75			2,00			2,50					
12,5 / 10 N/mm²	w/w	w/d	0,90			2,50			3,00					
	d/d		0,90			2,50			3,50					
15 / 12 N/mm²	w/w	w/d	0,90			3,00			3,50					
	d/d		1,20			3,00			4,00					

¹⁾ The minimum compressive strength of the single brick must not be less than 80% of the mean compressive strength.

²⁾ For temperature range 72/120°C: $N_{RK(72/120°C)} = 0,83 \cdot N_{RK(50/80°C)}$.

Table C16.2: Characteristic resistance to local brick failure or brick edge failure of a single anchor under shear loading

Anchor rod	M6	M8	M6	M8	-	M8	M10	M8	M10	-	M12	M16	M12	M16
Internal threaded anchor FIS E	-	-	M6	M8	11x85	-	-	-	-	M10	M12	-	-	-
Perforated sleeve FIS H K	12x50	12x85	16x85			16x130			20x85			20x130		
$V_{RK} = V_{RK,b} = V_{RK,c,II} = V_{RK,c,I}$ [kN]; temperature range 50/80°C and 72/120°C														
Mean compressive strength / Min. comp. strength single brick ¹⁾	Use conditions													
5 / 4 N/mm²	w/w	w/d	0,50			0,60			0,50			0,60		
			0,75			0,90			0,75			0,90		
			0,90			1,20			0,90			1,20		
			1,20			1,50			1,20			1,50		
			1,50			2,00			1,50			2,00		

¹⁾ The minimum compressive strength of the single brick must not be less than 80% of the mean compressive strength.

Factor for job site tests and displacements see annex C28.

Injection system ULTRAPROFI for masonry

Performance

Vertical perforated brick HLz, Characteristic resistance under tension and shear loading

Annex C16

Vertical perforated brick HLz, 2DF, EN 771-1:2011+A1:2015

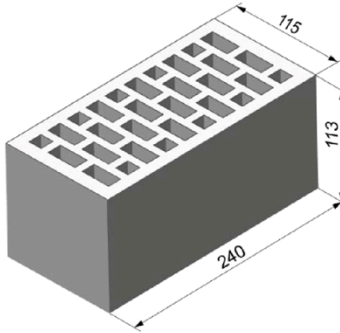

Producer	e.g. Wienerberger		
Nominal dimensions [mm]	length L	width W	height H
	240	115	113
Mean gross dry density ρ [kg/dm ³]	$\geq 1,4$		
Mean compressive strength / Min. compressive strength single brick ¹⁾ [N/mm ²]	7,5 / 6 or 12,5 / 10 or 20 / 16 or 25 / 20 or 35 / 28		
Standard or annex	EN 771-1:2011+A1:2015		

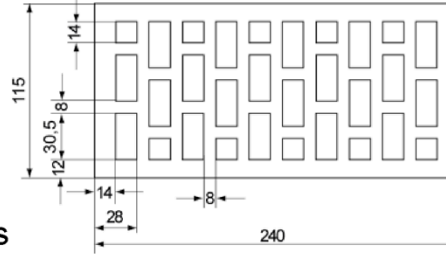

Dimension see also Annex B11

Table C17.1: Installation parameters

Anchor rod	M6	M8	M6	M8	-	M8	M10	-	M12	M16
Internal threaded anchor FIS E	-		-		M6	M8	-		M10	M12
					11x85				15x85	
Perforated sleeve FIS H K	12x50		12x85		16x85			20x85		

Anchor rod and internal threaded anchor FIS E with perforated sleeve FIS H K

Max. installation torque max T_{inst} [Nm]	2									
--	---	--	--	--	--	--	--	--	--	--

General installation parameters

Edge distance $c_{min} = c_{cr}$	80									
Spacing $s_{cr \parallel} = s_{min \parallel}$	240									
	$s_{cr \perp} = s_{min \perp}$	115								

Drilling method

Hammer drilling with hard metal hammer drill

¹⁾ The minimum compressive strength of the single brick must not be less than 80% of the mean compressive strength.

Table C17.2: Group factors

Anchor rod	M6	M8	M6	M8	-	M8	M10	-	M12	M16
Internal threaded anchor FIS E	-		-		M6	M8	-		M10	M12
					11x85				15x85	
Perforated sleeve FIS H K	12x50		12x85		16x85			20x85		

Group factors	$\alpha_{g,N} (s_{min \parallel})$	[-]	2,0							
	$\alpha_{g,V} (s_{min \parallel})$									
	$\alpha_{g,N} (s_{min \perp})$									
	$\alpha_{g,V} (s_{min \perp})$									

Injection system ULTRAPROFI for masonry

Performance

Vertical perforated brick HLz, 2DF, dimensions, installation parameters, Group factors

Annex C17

Vertical perforated brick HLz, 2DF, EN 771-1:2011+A1:2015

Table C18.1: Characteristic resistance to pull-out failure or brick breakout failure of a single anchor under tension loading

Anchor rod	M6	M8	M6	M8	-	M8	M10	-	M12	M16
Internal threaded anchor FIS E	-	-	M6	M8				M10	M12	-
			11x85					15x85		
Perforated sleeve FIS H K	12x50		12x85		16x85			20x85		
$N_{Rk} = N_{Rk,p} = N_{Rk,b} = N_{Rk,p,c} = N_{Rk,b,c}$ [kN]; temperature range 50/80°C²⁾										
Mean compressive strength / Min. compressive strength single brick ¹⁾	Use conditions									
7,5 / 6 N/mm ²	w/w	w/d	0,75	0,90	0,75			0,90		
	d/d		0,75	1,20	0,75			0,90		
12,5 / 10 N/mm ²	w/w	w/d	1,20	1,50	1,20			1,50		
	d/d		1,20	2,00	1,20			1,50		
20 / 16 N/mm ²	w/w	w/d	2,00	2,50	2,00			2,00		
	d/d		2,00	3,00	2,00			2,50		
25 / 20 N/mm ²	w/w	w/d	2,50	3,50	2,50			3,00		
	d/d		2,50	4,00	2,50			3,00		
35 / 28 N/mm ²	w/w	w/d	3,00	5,00	3,50			4,00		
	d/d		3,50	5,50	3,50			4,50		

¹⁾ The minimum compressive strength of the single brick must not be less than 80% of the mean compressive strength.

²⁾ For temperature range 72/120°C: $N_{Rk(72/120°C)} = 0,83 \cdot N_{Rk(50/80°C)}$.

Table C18.2: Characteristic resistance to local brick failure or brick edge failure of a single anchor under shear loading

Anchor rod	M6	M8	M6	M8	-	M8	M10	-	M12	M16
Internal threaded anchor FIS E	-	-	M6	M8				M10	M12	-
			11x85					15x85		
Perforated sleeve FIS H K	12x50		12x85		16x85			20x85		
$V_{Rk} = V_{Rk,b} = V_{Rk,c,II} = V_{Rk,c,L}$ [kN]; temperature range 50/80°C and 72/120°C										
Mean compressive strength / Min. compressive strength single brick ¹⁾	Use conditions									
7,5 / 6 N/mm ²	w/w w/d d/d	1,2	1,5	1,2	2,0	1,2	1,5		2,5	
12,5 / 10 N/mm ²		2,0	2,5	2,0	4,0	2,0	2,5		4,5	
20 / 16 N/mm ²		3,0	3,5	3,0	6,0	3,0	3,5		7,0	
25 / 20 N/mm ²		4,0	4,5	4,0	7,5	4,0	4,5		8,5	
35 / 28 N/mm ²		5,0	6,5	5,0	9,5	5,0	6,5		12,0	

¹⁾ The minimum compressive strength of the single brick must not be less than 80% of the mean compressive strength.

Factor for job site tests and displacements see annex C28.

Injection system ULTRAPROFI for masonry

Performance

Vertical perforated brick HLz, 2DF,
Characteristic resistance under tension and shear loading

Annex C18

Vertical perforated brick HLz filled with mineral wool, EN 771-1:2011+A1:2015

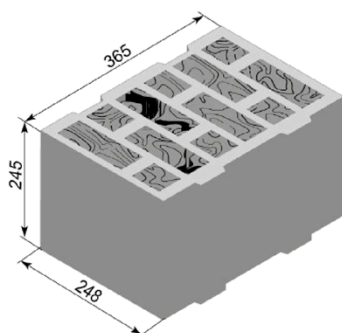

Producer	e.g. Wienerberger			
Nominal dimensions	[mm]	length L	width W	height H
		≥ 365	≥ 248	≥ 245
Mean gross dry density ρ	[kg/dm ³]	0,6		
Mean compressive strength / Min. compressive strength single brick ¹⁾	[N/mm ²]	10 / 8		
Standard or annex	EN 771-1:2011+A1:2015			

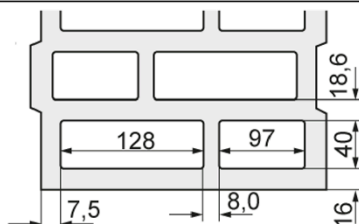

Dimension see also Annex B12

Table C19.1: Installation parameters
(Pre-positioned installation with perforated sleeve FIS H K)

Anchor rod	M6	M8	-	M8	M10	M8	M10	-	M12	M16	M12	M16
Internal threaded anchor FIS E	-		M6	M8	-		-		M10	M12	-	
			11x85						15x85			
Perforated sleeve FIS H K	12x85		16x85			16x130		20x85			20x130	

Anchor rod and internal threaded anchor FIS E with perforated sleeve FIS H K

Max. installation torque	max T_{inst} [Nm]	2	4
--------------------------	---------------------	---	---

General installation parameters

Edge distance	$c_{min} = c_{cr}$	[mm]	100
	$s_{min \parallel}$		250
	$s_{cr \parallel}$		
	$s_{min \perp}$		245
Spacing	$s_{cr \perp}$		

Drilling method

Hammer drilling with hard metal hammer drill

¹⁾ The minimum compressive strength of the single brick must not be less than 80% of the mean compressive strength.

Table C19.2: Group factors

Anchor rod	M6	M8	M8	M10	M8	M10	M12	M16	M12	M16
Perforated sleeve FIS H K	12x85		16x85		16x130		20x85		20x130	
Group factors	$\alpha_{g,N}(s_{min \parallel}) =$	[-]	2,0							
	$\alpha_{g,V}(s_{min \parallel}) =$									
	$\alpha_{g,N}(s_{min \perp}) =$									
	$\alpha_{g,V}(s_{min \perp}) =$									

Injection system ULTRAPROFI for masonry

Performance

Vertical perforated brick HLz filled with mineral wool, dimensions, installation parameters, Group factors

Annex C19

Vertical perforated brick HLz filled with mineral wool, EN 771-1:2011+A1:2015

Table C20.1: Characteristic resistance to pull-out failure or brick breakout failure of a single anchor under tension loading

Anchor rod	M6	M8	-	M8	M10	M8	M10	-	M12	M16	M12	M16	M12	M16
Internal threaded anchor FIS E	-		M6	M8	-		-		M10	M12	-		-	
	-		11x85		-		-		15x85		-		-	
Perforated sleeve FIS H K	12x85		16x85			16x130		20x85			20x130		20x200	
$N_{Rk} = N_{Rk,p} = N_{Rk,b} = N_{Rk,p,c} = N_{Rk,b,c}$ [kN]; temperature range 50/80°C²⁾														
Mean compressive strength / Min. compressive strength single brick ¹⁾	Use conditions													
10 / 8 N/mm ²	w/w	2,0	1,5	2,5		2,0		2,0	2,0	3,0				
	d/d	2,0	2,0	3,0		2,0		2,0	2,0	3,0				

- ¹⁾ The minimum compressive strength of the single brick must not be less than 80% of the mean compressive strength.
²⁾ For temperature range 72/120°C no performance assessed.

Table C20.2: Characteristic resistance to local brick failure or brick edge failure of a single anchor under shear loading (Pre-positioned installation)

Anchor rod	M6	M8	-	M8	M10	M8	M10	-	M12	M16	M12	M16	M12	M16
Internal threaded anchor FIS E	-		M6	M8	-		-		M10	M12	-		-	
	-		11x85		-		-		15x85		-		-	
Perforated sleeve FIS H K	12x85		16x85			16x130		20x85			20x130		20x200	
$V_{Rk} = V_{Rk,b} = V_{Rk,c,II} = V_{Rk,c,I}$ [kN]; temperature range 50/80°C²⁾														
Mean compressive strength / Min. compressive strength single brick ¹⁾	Use conditions													
10 / 8 N/mm ²	w/w	2,5	3,0	3,0		3,0		1,5		1,5	1,5	1,5	1,5	1,5
	d/d	2,5	3,0	3,0		3,0		1,5		1,5	1,5	1,5	1,5	1,5

- ¹⁾ The minimum compressive strength of the single brick must not be less than 80% of the mean compressive strength.
²⁾ For temperature range 72/120°C no performance assessed.

Factor for job site tests and displacements see annex C28.

Injection system ULTRAPROFI for masonry

Performance

Vertical perforated brick HLz filled with mineral wool, Characteristic resistance under tension loading and shear loading

Annex C20

Vertical perforated brick HLz, EN 771-1:2011+A1:2015

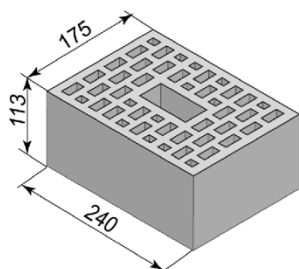

Producer	e.g. Wienerberger			
Nominal dimensions	[mm]	length L	width W	height H
		≥ 240	≥ 175	≥ 113
Mean gross dry density ρ	[kg/dm ³]	0,9		
Mean compressive strength / Min. compressive strength single brick ¹⁾	[N/mm ²]	12,5 / 10		
Standard or annex	EN 771-1:2011+A1:2015			

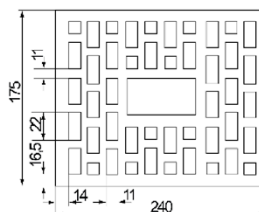

Dimension see also Annex B12

Table C21.1: Installation parameters
(Pre-positioned installation with perforated sleeve FIS H K)

Anchor rod	M6	M8	-	M8	M10	M8	M10	-	M12	M16	M12	M16
Internal threaded anchor FIS E	-		M6	M8	-		-		M10	M12	-	
			11x85						15x85			
Perforated sleeve FIS H K	12x85		16x85			16x130		20x85			20x130	

Anchor rod and internal threaded anchor FIS E with perforated sleeve FIS H K

Max. installation torque	max T_{inst} [Nm]	2	4									
--------------------------	---------------------	---	---	--	--	--	--	--	--	--	--	--

General installation parameters

Edge distance	$c_{min} = c_{cr}$	100										
Spacing	$s_{min \parallel}$	240										
	$s_{cr \parallel}$	240										
	$s_{min \perp}$	115										
	$s_{cr \perp}$	115										

Drilling method

Hammer drilling with hard metal hammer drill

¹⁾ The minimum compressive strength of the single brick must not be less than 80% of the mean compressive strength.

Table C21.2: Group factors

Anchor rod	M6	M8	M8	M10	M8	M10	M12	M16	M12	M16	
Perforated sleeve FIS H K	12x85		16x85		16x130		20x85		20x130		
Group factors	$\alpha_{g,N}(s_{min \parallel}) =$	[-]	2,0								
	$\alpha_{g,V}(s_{min \parallel}) =$										
	$\alpha_{g,N}(s_{min \perp}) =$										
	$\alpha_{g,V}(s_{min \perp}) =$										

Injection system ULTRAPROFI for masonry

Performance

Vertical perforated brick HLz, dimensions, installation parameters, Group factors

Annex C21

Vertical perforated brick HLz, EN 771-1:2011+A1:2015

Table C22.1: Characteristic resistance to pull-out failure or brick breakout failure of a single anchor under tension loading (Pre-positioned installation)

Anchor rod	M6	M8	-		M8	M10	M8	M10	-		M12	M16	M12	M16
Internal threaded anchor FIS E	-		M6	M8	-		-		M10	M12	-		-	
	-		11x85		-		-		15x85		-		-	
Perforated sleeve FIS H K	12x85		16x85			16x130			20x85			20x130		

$N_{Rk} = N_{Rk,p} = N_{Rk,b} = N_{Rk,p,c} = N_{Rk,b,c}$ [kN]; temperature range 50/80°C²⁾

Mean compressive strength/ Min. compressive strength single brick ¹⁾	Use con- ditions														
12,5 / 10 N/mm ²	w/w	3,5	4,0			4,5			4,5			4,0			
	d/d	4	4,5			5,0			5,0			4,0			

¹⁾ The minimum compressive strength of the single brick must not be less than 80% of the mean compressive strength.

²⁾ For temperature range 72/120°C no performance assessed.

Table C22.2: Characteristic resistance to local brick failure or brick edge failure of a single anchor under shear loading (Pre-positioned installation)

Anchor rod	M6	M8	-		M8	M10	M8	M10	-		M12	M16	M12	M16
Internal threaded anchor FIS E	-		M6	M8	-		-		M10	M12	-		-	
	-		11x85		-		-		15x85		-		-	
Perforated sleeve FIS H K	12x85		16x85			16x130			20x85			20x130		

$V_{Rk} = V_{Rk,b} = V_{Rk,c,II} = V_{Rk,c,I}$ [kN]; temperature range 50/80°C²⁾

Mean compressive strength / Min. compressive strength single brick ¹⁾	Use con- ditions														
12,5 / 10 N/mm ²	w/w	4,0	5,5	4,0	5,5	5,5	7,0	5,5	7,0	7,0	6,0	6,0	8,0	6,0	8,0
	d/d	4,0	5,5	4,0	5,5	5,5	7,0	5,5	7,0	7,0	6,0	6,0	8,0	6,0	8,0

¹⁾ The minimum compressive strength of the single brick must not be less than 80% of the mean compressive strength.

²⁾ For temperature range 72/120°C no performance assessed.

Factor for job site tests and displacements see annex C28.

Injection system ULTRAPROFI for masonry

Performance

Vertical perforated brick HLz, Characteristic resistance under tension loading and shear loading

Annex C22

Light-weight concrete hollow block Hbl, EN 771-3:2011+A1:2015

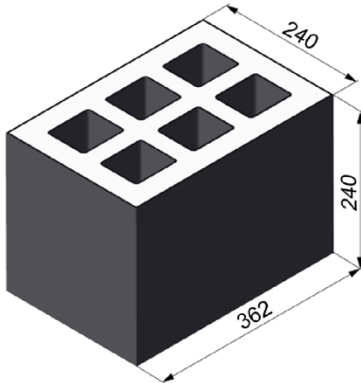

Producer	-			
Nominal dimensions	[mm]	length L	width W	height H
		362	240	240
Mean gross dry density ρ	[kg/dm ³]	$\geq 1,0$		
Mean compressive strength / Min. compressive strength single brick ¹⁾	[N/mm ²]	2,5 / 2 or 5 / 4		
Standard or annex	EN 771-3:2011+A1:2015			

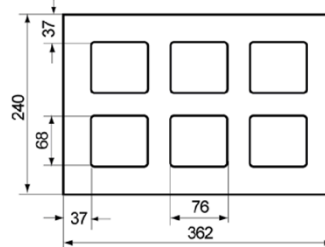

Dimension see also Annex B12

Table C23.1: Installation parameters
(Pre-positioned installation with perforated sleeve FIS H K)

Anchor rod	M6	M8	M6	M8	-	M8	M10	M8	M10	-	M12	M16	M12	M16	M12	M16
Internal threaded anchor FIS E	-		-		M6	M8	-		-		M10	M12	-		-	
					11x85						15x85					
Perforated sleeve FIS H K	12x50		12x85		16x85			16x130		20x85			20x130		20x200	

Anchor rod and internal threaded anchor FIS E with perforated sleeve FIS H K

Max. installation torque	$\max T_{inst}$ [Nm]	2
--------------------------	----------------------	---

General installation parameters

Edge distance	$c_{min} = c_{cr}$	60
Spacing	$s_{min \parallel}$	100
	$s_{cr \parallel}$	362
	$s_{min \perp} = s_{cr \perp}$	240

Drilling method

Hammer drilling with hard metal hammer drill

¹⁾ The minimum compressive strength of the single brick must not be less than 80% of the mean compressive strength.

Table C23.2: Group factors

Anchor rod	M6	M8	M6	M8	-	M8	M10	M8	M10	-	M12	M16	M12	M16	M12	M16
Internal threaded anchor FIS E	-		-		M6	M8	-		-		M10	M12	-		-	
					11x85						15x85					
Perforated sleeve FIS H K	12x50		12x85		16x85			16x130		20x85			20x130		20x200	

Group factors	$\alpha_{g,N} (s_{min \parallel})$	[-]	1,2
	$\alpha_{g,V} (s_{min \parallel})$		1,1
	$\alpha_{g,N} (s_{min \perp})$		2,0
	$\alpha_{g,V} (s_{min \perp})$		

Injection system ULTRAPROFI for masonry

Performance

Light-weight concrete hollow block Hbl, dimensions, installation parameters, Group factors

Annex C23

Light-weight concrete hollow block Hbl, EN 771-3:2011+A1:2015

Table C24.1: Characteristic resistance to pull-out failure or brick breakout failure of a single anchor under tension loading (Pre-positioned installation)

Anchor rod	M6	M8	M6	M8	-	M8	M10	M8	M10	-	M12	M16	M12	M16	M12	M16	
Internal threaded anchor FIS E	-		-		M6	M8	-		-		M10	M12	-		-		
	-		-		11x85		-		-		15x85		-		-		
Perforated sleeve FIS H K	12x50		12x85		16x85			16x130			20x85			20x130		20x200	

$N_{RK} = N_{RK,p} = N_{RK,b} = N_{RK,p,c} = N_{RK,b,c}$ [kN]; temperature range 50/80°C²⁾

Mean compressive strength / Min. compressive strength single brick ¹⁾	Use con- ditions															
	2,5 / 2 N/mm ²	w/w	w/d	1,2				1,5				2,5				
d/d		d/d	1,2				1,5				2,5					
5 / 4 N/mm ²	w/w	w/d	2,0				3,0				5,0					
	d/d	d/d	2,5				3,0				5,5					

¹⁾ The minimum compressive strength of the single brick must not be less than 80% of the mean compressive strength.

²⁾ For temperature range 72/120°C: $N_{RK(72/120^\circ C)} = 0,83 \cdot N_{RK(50/80^\circ C)}$.

Table C24.2: Characteristic resistance to local brick failure or brick edge failure of a single anchor under shear loading (Pre-positioned installation)

Anchor rod	M6	M8	M6	M8	-	M8	M10	M8	M10	-	M12	M16	M12	M16	M12	M16	
Internal threaded anchor FIS E	-		-		M6	M8	-		-		M10	M12	-		-		
	-		-		11x85		-		-		15x85		-		-		
Perforated sleeve FIS H K	12x50		12x85		16x85			16x130			20x85			20x130		20x200	

$V_{RK} = V_{RK,b} = V_{RK,c,II} = V_{RK,c,I}$ [kN]; temperature range 50/80°C and 72/120°C

Mean compressive strength / Min. compressive strength single brick ¹⁾	Use con- ditions															
	2,5 / 2 N/mm ²	w/w	w/d	0,9												
d/d		d/d	0,9													
5 / 4 N/mm ²	w/w	w/d	2,0													
	d/d	d/d	2,0													

¹⁾ The minimum compressive strength of the single brick must not be less than 80% of the mean compressive strength.

Factor for job site tests and displacements see annex C28.

Injection system ULTRAPROFI for masonry

Performance

Light-weight concrete hollow block Hbl, Characteristic resistance under tension loading and shear loading

Annex C24

Autoclaved aerated concrete, EN 771-4:2011+A1:2015

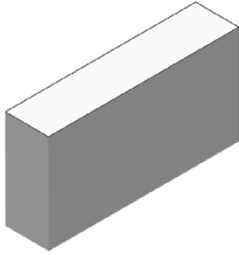

Producer	e.g. Ytong		
Mean gross dry density ρ [kg/dm ³]	0,35	0,5	0,65
Mean compressive strength / Min. compressive strength single brick ¹⁾ [N/mm ²]	2,5 / 2	5 / 4	8 / 6
Standard or annex	EN 771-4:2011+A1:2015		

Table C25.1: Installation parameters

Anchor rod	M6	M8	M10	M12	M16	-	-					
Internal threaded anchor FIS E	-	-	-	-	-	M6	M8	M10	M12			
						11x85		15x85				
Anchor rod and internal threaded anchor FIS E without perforated sleeve												
Effective anchorage depth h_{ef} [mm]	100	200	100	200	100	200	100	200	85			
Max. installation torque $\max T_{inst}$ [Nm]	1	4	1	8	2	12	2	16	2	20	1	2
General installation parameters												
Edge distance $c_{min} = c_{cr}$	100											
Spacing $s_{cr \parallel} = s_{min \parallel}$	250											
$h_{ef}=200mm$ $s_{min \parallel}$	80											
$h_{ef}=200mm$ $s_{cr \parallel}$ [mm]	3x h_{ef}											
$s_{cr \perp} = s_{min \perp}$	250											
$h_{ef}=200mm$ $s_{min \perp}$	80											
$h_{ef}=200mm$ $s_{cr \perp}$	3x h_{ef}											
Drilling method												
Hammer drilling with hard metal hammer drill												
¹⁾ The minimum compressive strength of the single brick must not be less than 80% of the mean compressive strength.												
Injection system ULTRAPROFI for masonry								Annex C25				
Performance		Autoclaved aerated concrete, dimensions, installation parameters										

Autoclaved aerated concrete, EN 771-4:2011+A1:2015

Table C26.1: Group factors for autoclaved aerated concrete
(Min. compressive strength single brick = 2 N/mm²)

Anchor rod	M6	M8	M10	M12	M16	-		-	
Internal threaded anchor FIS E	-	-	-	-	-	M6	M8	M10	M12
						11x85		15x85	
Group factors	[-]	$h_{ef}=200 \alpha_{g,N} (S_{min} \parallel)$	1,6			- ¹⁾		- ¹⁾	
		$h_{ef}=200 \alpha_{g,V} (S_{min} \parallel)$	1,1			- ¹⁾		- ¹⁾	
		$\alpha_{g,N} \parallel, \alpha_{g,V} (S_{min} \parallel)$	2,0						
		$h_{ef}=200 \alpha_{g,N} (S_{min} \perp)$	1,6			- ¹⁾		- ¹⁾	
		$h_{ef}=200 \alpha_{g,V} (S_{min} \perp)$	0,8			- ¹⁾		- ¹⁾	
		$\alpha_{g,N} \perp, \alpha_{g,V} (S_{min} \perp)$	2,0						

¹⁾ No performance assessed.

Table C26.2: Group factors for autoclaved aerated concrete
(Min. compressive strength single brick = 4 N/mm²)

Anchor rod	M6	M8	M10	M12	M16	-		-	
Internal threaded anchor FIS E	-	-	-	-	-	M6	M8	M10	M12
						11x85		15x85	
Group factors	[-]	$h_{ef}=200 \alpha_{g,N} (S_{min} \parallel)$	0,7			- ¹⁾		- ¹⁾	
		$h_{ef}=200 \alpha_{g,V} (S_{min} \parallel)$	2,0			- ¹⁾		- ¹⁾	
		$\alpha_{g,N} \parallel, \alpha_{g,V} (S_{min} \parallel)$	2,0						
		$h_{ef}=200 \alpha_{g,N} (S_{min} \perp)$	0,7			- ¹⁾		- ¹⁾	
		$h_{ef}=200 \alpha_{g,V} (S_{min} \perp)$	1,2			- ¹⁾		- ¹⁾	
		$\alpha_{g,N} \perp, \alpha_{g,V} (S_{min} \perp)$	2,0						

¹⁾ No performance assessed.

Table C26.3: Group factors for autoclaved aerated concrete
(Min. compressive strength single brick = 6 N/mm²)

Anchor rod	M6	M8	M10	M12	M16	-		-	
Internal threaded anchor FIS E	-	-	-	-	-	M6	M8	M10	M12
						11x85		15x85	
Group factors	[-]	$h_{ef}=200 \alpha_{g,N} (S_{min} \parallel)$	0,7			- ¹⁾		- ¹⁾	
		$h_{ef}=200 \alpha_{g,V} (S_{min} \parallel)$	2,0			- ¹⁾		- ¹⁾	
		$\alpha_{g,N} \parallel, \alpha_{g,V} (S_{min} \parallel)$	2,0						
		$h_{ef}=200 \alpha_{g,N} (S_{min} \perp)$	0,7			- ¹⁾		- ¹⁾	
		$h_{ef}=200 \alpha_{g,V} (S_{min} \perp)$	1,2			- ¹⁾		- ¹⁾	
		$\alpha_{g,N} \perp, \alpha_{g,V} (S_{min} \perp)$	2,0						

¹⁾ No performance assessed.

Injection system ULTRAPROFI for masonry

Performance
Autoclaved aerated concrete, Group factors

Annex C26

Autoclaved aerated concrete, EN 771-4:2011+A1:2015

Table C27.1: Characteristic resistance to pull-out failure or brick breakout failure of a single anchor under tension loading

Anchor rod		M6	M8	M10	M12	M16	-		-				
Internal threaded anchor FIS E		-	-	-	-	-	M6	M8	M10	M12			
							11x85		15x85				
$N_{Rk} = N_{Rk,p} = N_{Rk,b} = N_{Rk,p,c} = N_{Rk,b,c}$ [kN]; temperature range 50/80°C³⁾													
Mean compressive strength / Min. compressive strength single brick ²⁾	Use conditions	Effective anchorage depth h_{ef} [mm]											
		100	200	100	200	100	200	100	200	100	200	85	
2,5 / 2 N/mm ²	w/w w/d	1,2	1,2	1,5	2,0	1,5	3,0	1,5	3,0	2,0	3,0	1,5	1,5
	d/d	1,5	3,0	1,5	3,0	1,5	3,5	2,0	4,0	2,0	4,0	1,5	1,5
5 / 4 N/mm ²	w/w w/d	1,2	- ¹⁾	2,0	1,5	2,5	3,5	2,5	3,5	2,0	3,5	2,0	1,5
	d/d	1,5	- ¹⁾	2,0	3,0	3,0	5,0	2,5	5,0	2,0	5,0	2,0	1,5
8 / 6 N/mm ²	w/w w/d	1,5	- ¹⁾	3,0	2,5	4,5	5,0	4,5	7,0	3,0	8,5	3,5	2,5
	d/d	1,5	- ¹⁾	3,5	4,0	5,0	7,0	5,0	9,0	3,0	11,5	3,5	2,5

¹⁾ No performance assessed.

²⁾ The minimum compressive strength of the single brick must not be less than 80% of the mean compressive strength.

³⁾ For temperature range 72/120°C: $N_{Rk(72/120°C)} = 0,83 \cdot N_{Rk(50/80°C)}$.

Table C27.2: Characteristic resistance to local brick failure or brick edge failure of a single anchor under shear loading

Anchor rod		M6	M8	M10	M12	M16	-		-				
Internal threaded anchor FIS E		-	-	-	-	-	M6	M8	M10	M12			
							11x85		15x85				
$V_{Rk} = V_{Rk,b} = V_{Rk,c,II} = V_{Rk,c,L}$ [kN]; temperature range 50/80°C and 72/120°C													
Mean compressive strength / Min. compressive strength single brick ²⁾	Use conditions	Effective anchorage depth h_{ef} [mm]											
		100	200	100	200	100	200	100	200	100	200	85	
2,5 / 2 N/mm ²	w/w w/d	1,2	1,2	1,2	1,2	1,2	1,2	1,5	1,2	1,2	1,2	1,2	1,5
	d/d	1,2	1,2	1,2	1,2	1,2	1,2	1,5	1,2	1,2	1,2	1,2	1,5
5 / 4 N/mm ²	w/w w/d	2,0	- ¹⁾	2,5	2,0	2,0	2,0	2,5	2,0	2,0	2,0	2,0	2,5
	d/d	2,0	- ¹⁾	2,5	2,0	2,0	2,0	2,5	2,0	2,0	2,0	2,0	2,5
8 / 6 N/mm ²	w/w w/d	2,5	- ¹⁾	3,0	2,5	3,0	3,0	3,5	4,0	4,5	4,5	2,5	3,5
	d/d	2,5	- ¹⁾	3,0	2,5	3,0	3,0	3,5	4,0	4,5	4,5	2,5	3,5

¹⁾ No performance assessed.

²⁾ The minimum compressive strength of the single brick must not be less than 80% of the mean compressive strength

Factor for job site tests and displacements see annex C28.

Injection system ULTRAPROFI for masonry

Performance

Autoclaved aerated concrete,
Characteristic resistance under tension and shear loading

Annex C27

β-factors for job site tests; displacements

Table C28.1: β-factors for job site tests

use conditions		w/w and w/d		d/d	
temperature range [°C]		50/80	72/120	50/80	72/120
Material	Size	β-factors [-]			
solid units	M6	0,55	0,46	0,96	0,80
	M8	0,57	0,51		
	M10	0,59	0,52		
	M12 FIS E 11x85	0,60	0,54		
	M16 FIS E 15x85	0,62	0,52		
	FIS H 16x85 K	0,55	0,46		
hollow units	all sizes	0,86	0,72	0,96	0,80
Autoclaved aerated concrete cylindrical drill hole	all sizes	0,73	0,73	0,81	0,81

Table C28.2: Displacements

Material	N /[kN]	δN ₀ [mm]	δN _∞ [mm]	V [kN]	δV ₀ [mm]	δV _∞ [mm]
solid units and autoclaved aerated concrete h _{ef} =100mm	$\frac{N_{Rk}}{1,4 \cdot \gamma_{Mm}}$	0,03	0,06	$\frac{V_{Rk}}{1,4 \cdot \gamma_{Mm}}$	0,82	0,88
hollow units	$\frac{N_{Rk}}{1,4 \cdot \gamma_{Mm}}$	0,48	0,06	$\frac{V_{Rk}}{1,4 \cdot \gamma_{Mm}}$	1,71	2,56
solid brick Mz NF Annex C4 - C7	$\frac{N_{Rk}}{1,4 \cdot \gamma_{Mm}}$	0,74	1,48	$\frac{V_{Rk}}{1,4 \cdot \gamma_{Mm}}$	1,23	1,85
solid brick KS NF Annex C8 / C9	$\frac{N_{Rk}}{1,4 \cdot \gamma_{Mm}}$	0,20	0,40	$\frac{V_{Rk}}{1,4 \cdot \gamma_{Mm}}$	0,91	1,37
AAC h _{ef} =200 mm Annex C25 – C27	$\frac{N_{Rk}}{1,4 \cdot \gamma_{Mm}}$	1,03	2,06	$\frac{V_{Rk}}{1,4 \cdot \gamma_{Mm}}$	1,25	1,88

For anchorage in autoclaved aerated concrete (AAC), the partial factor γ_{MAAC} shall be used instead of γ_{Mm} .

Injection system ULTRAPROFI for masonry

Performance
β-factors for job site tests; displacements

Annex C28