

Public-law institution jointly founded by the federal states and the Federation

European Technical Assessment Body  
for construction products



## European Technical Assessment

ETA-17/0436  
of 26 January 2026

English translation prepared by DIBt - Original version in German language

### General Part

Technical Assessment Body issuing the European Technical Assessment:

Deutsches Institut für Bautechnik

Trade name of the construction product

Injection system ULTRAPROFI

Product family to which the construction product belongs

Bonded fasteners and bonded expansion fasteners for use in concrete

Manufacturer

SEEFELDER GmbH  
Dieselstraße 5  
84088 Neufahrn in Niederbayern

Manufacturing plant

Seefelder

This European Technical Assessment contains

23 pages including 3 annexes which form an integral part of this assessment

This European Technical Assessment is issued in accordance with Article 95(4) of Regulation (EU) No 2024/3110, on the basis of

EAD 330499-02-0601

This version replaces

ETA-17/0436 issued on 12 December 2017

The European Technical Assessment is issued by the Technical Assessment Body in its official language. Translations of this European Technical Assessment in other languages shall fully correspond to the original issued document and shall be identified as such.

Communication of this European Technical Assessment, including transmission by electronic means, shall be in full. However, partial reproduction may only be made with the written consent of the issuing Technical Assessment Body. Any partial reproduction shall be identified as such.

This European Technical Assessment may be withdrawn by the issuing Technical Assessment Body, in particular pursuant to information by the Commission in accordance with Article 36(3) of Regulation (EU) No 2024/3110.

## Specific Part

### 1 Technical description of the product

The "Injection system ULTRAPROFI" is a bonded anchor consisting of a cartridge with injection mortar according to Annex A3 and a steel element according to Annex A4.

The steel element is placed into a drilled hole filled with injection mortar and is anchored via the bond between metal part, injection mortar and concrete.

The product description is given in Annex A.

### 2 Specification of the intended use in accordance with the applicable European Assessment Document

The performances given in Section 3 are only valid if the anchor is used in compliance with the specifications and conditions given in Annex B.

The verifications and assessment methods on which this European Technical Assessment is based lead to the assumption of a working life of the anchor of at least 50 years. The indications given on the working life cannot be interpreted as a guarantee given by the producer, but are to be regarded only as a means for choosing the right products in relation to the expected economically reasonable working life of the works.

### 3 Performance of the product and references to the methods used for its assessment

#### 3.1 Mechanical resistance and stability (BWR 1)

Essential characteristic	Performance
Characteristic resistance to tension load (static and quasi-static loading)	See Annex B3, B4, C1 bis C5
Characteristic resistance to shear load (static and quasi-static loading)	See Annex C2, C3
Displacements under short-term and long-term loading	See Annex C6
Characteristic resistance and displacements for seismic performance categories C1 and C2	No performance assessed

#### 3.2 Safety in case of fire (BWR 2)

Essential characteristic	Performance
Reaction to fire	Class A1
Resistance to fire	No performance assessed

#### 3.3 Hygiene, health and the environment (BWR 3)

Essential characteristic	Performance
Content, emission and/or release of dangerous substances	No performance assessed

**4 Assessment and verification of constancy of performance (AVCP) system applied, with reference to its legal base**

In accordance with the European Assessment Document EAD 330499-02-0601 the applicable European legal act is: [96/582/EC].

The system to be applied is: 1

**5 Technical details necessary for the implementation of the AVCP system, as provided for in the applicable European Assessment Document**

Technical details necessary for the implementation of the AVCP system are laid down in the control plan deposited at Deutsches Institut für Bautechnik.

Issued in Berlin 26 January 2026 by Deutsches Institut für Bautechnik

Dipl.-Ing. Beatrix Wittstock  
Head of Section

*beglaubigt:*  
Baderschneider

### Installation conditions part 1

#### Anchor rod FIS A / RG M (Anchor rod) and standard threaded rod (threaded rod)

##### Pre-positioned installation

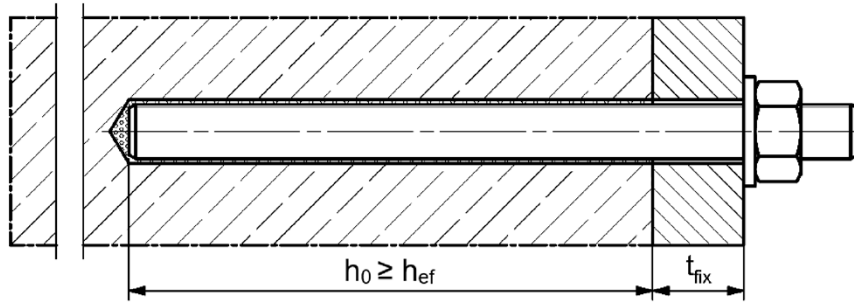

##### Push through installation (annular gap filled with mortar)

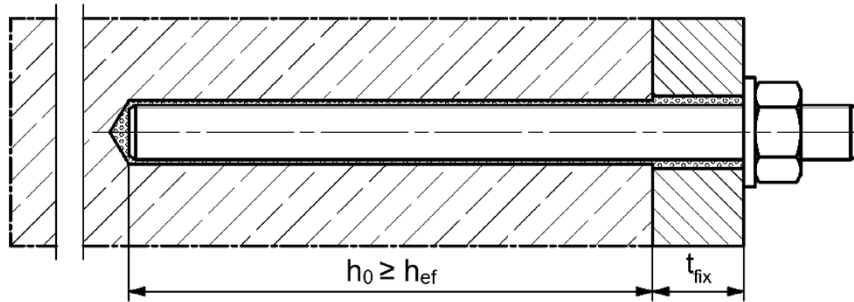

##### Pre-positioned or push through installation with subsequently injected Ultraprofi filling disc (annular gap filled with mortar)

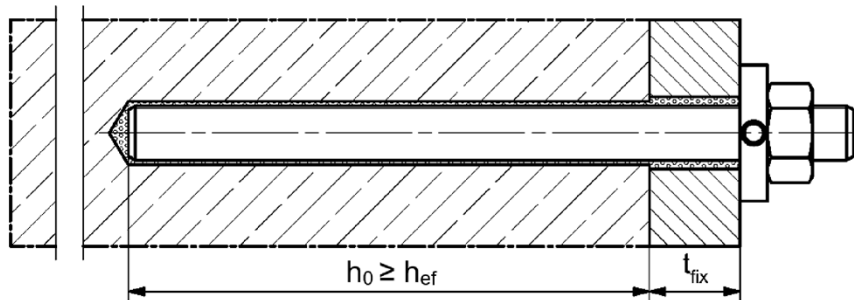

Figures not to scale

$h_0$  = drill hole depth

$h_{ef}$  = effective embedment depth

$t_{fix}$  = thickness of fixture

Injection system ULTRAPROFI

**Product description**  
Installation conditions part 1

**Annex A1**

## Installation conditions part 2

### internal threaded anchor RG M I (RG M I)

#### Pre-positioned installation

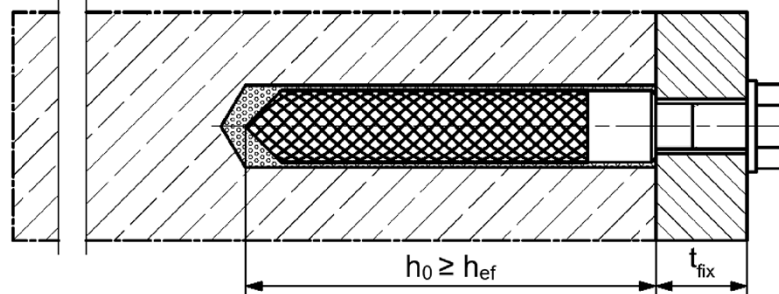

#### Pre-positioned installation with subsequently injected Ultraprofi filling disc (annular gap filled with mortar)

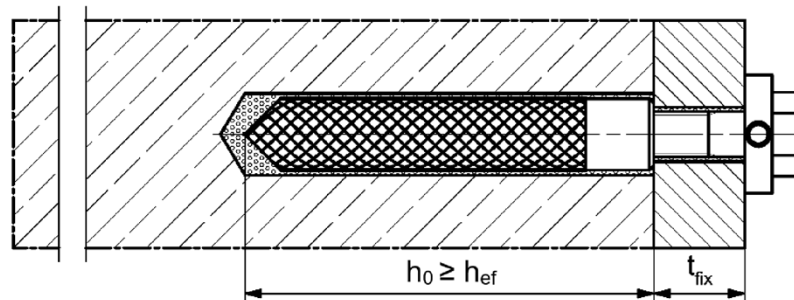

Figures not to scale

$h_0$  = drill hole depth

$h_{ef}$  = effective embedment depth

$t_{fix}$  = thickness of fixture

Injection system ULTRAPROFI

**Product description**  
Installation conditions part 2

**Annex A2**

## Overview system components part 1

### Injection cartridge (shuttle cartridge) with sealing cap; Sizes: 360 ml, 825 ml

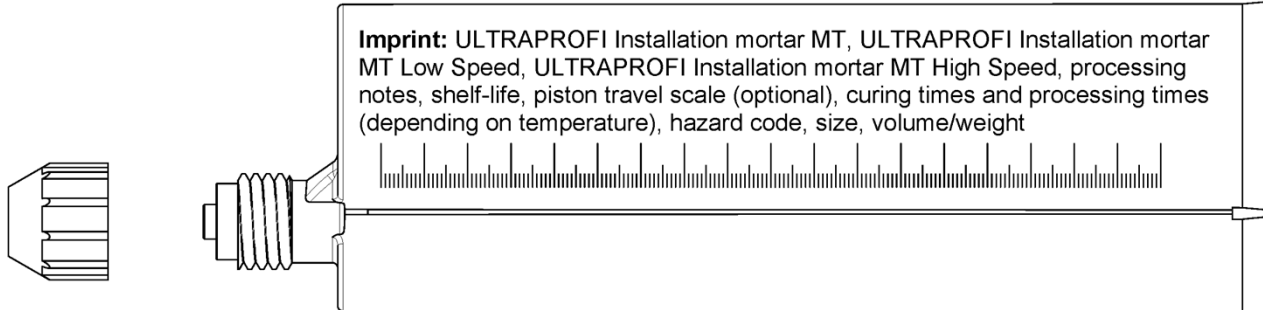

### Injection cartridge (coaxial cartridge) with sealing cap; Sizes: 100 ml, 150 ml, 300 ml, 380 ml, 400 ml, 410 ml

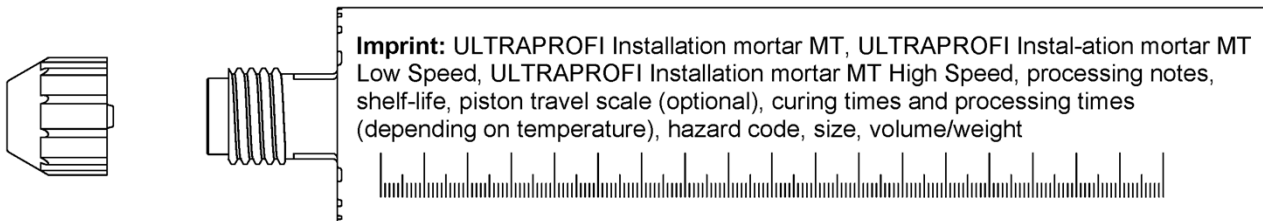

### Static mixer FIS MR Plus for injection cartridges up to 410 ml

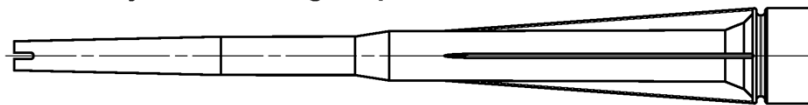

### Static mixer FIS JMR for injection cartridges with 825 ml

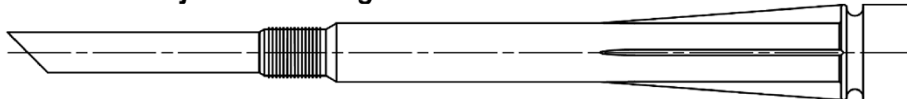

### Injection adapter and extension tube Ø 9 for static mixer FIS MR Plus; Injection adapter and extension tube Ø 9 or Ø 15 for static mixer FIS JMR

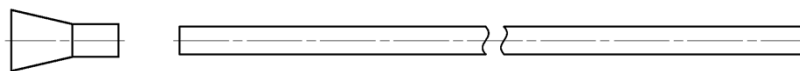

### Cleaning brush BS



### Blow-out pump ABG



### Compressed-air cleaning tool ABP



Figures not to scale

Injection system ULTRAPROFI

#### Product description

Overview system components part 1;  
cartridges / static mixer / accessories

**Annex A3**

## Overview system components part 2

### Anchor rod / Threaded rod

Size: M6, M8, M10, M12, M16, M20, M24, M27, M30

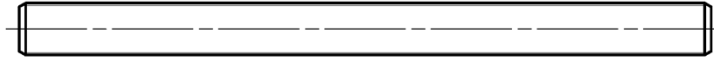

### Internal threaded anchor RG M I

Size: M8, M10, M12, M16, M20



### Screw / Threaded rod / washer / hexagon nut

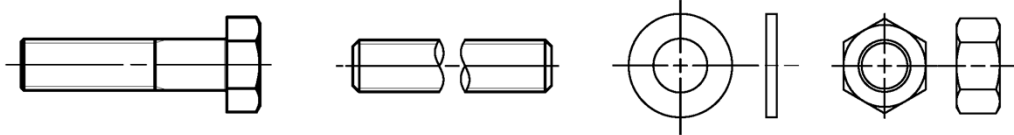

### Ultraprofi filling disc with injection adapter

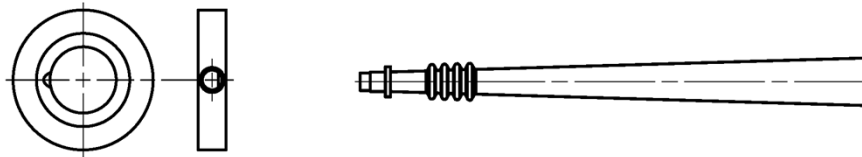

Figures not to scale

Injection system ULTRAPROFI

#### Product description





Overview system components part 2; metal parts, injection adapter

**Annex A4**

<b>Table A5.1: Materials</b>				
<b>Part</b>	<b>Designation</b>	<b>Material</b>		
1	Injection cartridge	Mortar, hardener, filler		
	Steel grade	Steel zinc plated (zp, hdg)	Stainless steel R acc. to EN 10088-1:2023 Corrosion resistance class CRC III acc. to EN 1993-1-4: 2006+A1:2015	High corrosion resistant steel HCR acc. to EN 10088-1:2023 Corrosion resistance class CRC V acc. to EN 1993-1-4: 2006+ A1:2015
2	Anchor rod / Threaded rod	Property class 4.8, 5.8 or 8.8; EN ISO 898-1:2013 electroplated $\geq 5 \mu\text{m}$ , EN ISO 4042:2022 or hot dip galvanised $\geq 40 \mu\text{m}$ EN ISO 10684:2004+AC:2009 $f_{uk} \leq 1000 \text{ N/mm}^2$ $A_5 > 8\%$ fracture elongation	Property class 50, 70 or 80 EN ISO 3506-1:2020 1.4401; 1.4404; 1.4578; 1.4571; 1.4439; 1.4362; 1.4062, 1.4662, 1.4462; EN 10088-1:2023 $f_{uk} \leq 1000 \text{ N/mm}^2$ $A_5 > 8\%$ fracture elongation	Property class 50, 70 or 80 EN ISO 3506-1:2020 or property class HRC 70 with $f_{yk} = 560 \text{ N/mm}^2$ ; 1.4565; 1.4529; EN 10088-1:2023 $f_{uk} \leq 1000 \text{ N/mm}^2$ $A_5 > 8\%$ fracture elongation
3	Washer ISO 7089:2000	electroplated $\geq 5 \mu\text{m}$ , EN ISO 4042:2022 or hot dip galvanised $\geq 40 \mu\text{m}$ EN ISO 10684:2004+AC:2009	1.4401; 1.4404; 1.4578; 1.4571; 1.4439; 1.4362; EN 10088-1:2023	1.4565; 1.4529; EN 10088-1:2023
4	Hexagon nut	Property class 5 or 8 acc. EN ISO 898-2:2022 electroplated $\geq 5 \mu\text{m}$ , EN ISO 4042:2022 or hot dip galvanised $\geq 40 \mu\text{m}$ EN ISO 10684:2004+AC:2009	Property class 50, 70 or 80 acc. EN ISO 3506-2:2020 1.4401; 1.4404; 1.4578; 1.4571; 1.4439; 1.4362; EN 10088-1:2023	Property class 50, 70 or 80 acc. EN ISO 3506-2:2020 1.4565; 1.4529 EN 10088-1:2023
5	RG M I	Property class 5.8 ISO 898-1:2013 electroplated $\geq 5 \mu\text{m}$ , EN ISO 4042:2022	Property class 70 EN ISO 3506-1:2020; 1.4401; 1.4404; 1.4578; 1.4571; 1.4439; 1.4362; EN 10088-1:2023	Property class 70 EN ISO 3506-1:2020 1.4565; 1.4529; EN 10088-1:2023
6	Commercial standard screw or threaded rod for RG M I	Property class 5.8 or 8.8; EN ISO 898-1:2013 electroplated $\geq 5 \mu\text{m}$ , EN ISO 4042:2022 $A_5 > 8\%$ fracture elongation	Property class 70 EN ISO 3506-1:2020 1.4401; 1.4404; 1.4578; 1.4571; 1.4439; 1.4362; EN 10088-1:2023 $A_5 > 8\%$ fracture elongation	Property class 70 EN ISO 3506-1:2020 1.4565; 1.4529; EN 10088-1:2023 $A_5 > 8\%$ fracture elongation
7	Ultraprofi filling disc	electroplated $\geq 5 \mu\text{m}$ , EN ISO 4042:2022 or hot dip galvanised $\geq 40 \mu\text{m}$ EN ISO 10684:2004+AC:2009	1.4401; 1.4404; 1.4578; 1.4571; 1.4439; 1.4362; EN 10088-1:2023	1.4565; 1.4529; EN 10088-1:2023
Injection system ULTRAPROFI				<b>Annex A5</b>
Product description Materials				

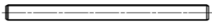
## Specifications of intended use part 1

**Table B1.1:** Overview use and performance categories

		Injection system ULTRAPROFI with ...			
		Anchor rod / Threaded rod 	Internal threaded anchor RG M I 		
Hammer drilling with standard drill bit 		all sizes			
Hammer drilling with hollow drill bit 		Nominal drill bit diameter ( $d_0$ ) 12 mm to 35 mm (fischer „FHD“, Heller „Duster Expert“, Bosch „Speed Clean“; Hilti „TE-CD, TE-YD“, DreBo „D-Plus“, DreBo „D-Max“)			
Static and quasi static loading, in	uncracked concrete	all sizes	Tables: C1.1 C3.1 C4.1 C6.1	all sizes	Tables: C2.1 C3.1 C5.1 C6.2
	cracked concrete	M8 to M20		- <sup>1)</sup>	
Seismic performance category	C1  C2	- <sup>1)</sup>			
Use category	I1 dry or wet concrete	all sizes			
	I2 water filled hole <sup>2)</sup>	M 12 to M 30	all sizes		
Installation direction	D3 (downward and horizontal and upwards (e.g. overhead) installation)				
Installation temperature	$T_{i,min} = -10\text{ °C}$ to $T_{i,max} = +40\text{ °C}$ for the standard variation of temperature after installation				
Service temperature	Temperature range I	-40 °C to +80 °C	(max. short term temperature +80 °C; max. long term temperature +50 °C)		
	Temperature range II	-40 °C to +120 °C	(max. short term temperature +120 °C; max. long term temperature +72 °C)		
<sup>1)</sup> Performance not assessed. <sup>2)</sup> Valid for shuttle cartridges with 360 ml, 825 ml and coaxial cartridges with 380 ml, 400 ml, 410 ml.					
Injection system ULTRAPROFI					<b>Annex B1</b>
Intended use Specifications part 1					

## Specifications of intended use part 2

### Base materials:

- Compacted reinforced or unreinforced normal weight concrete without fibres of strength classes C20/25 to C50/60 according to EN 206:2013+A2:2021.

### Use conditions (Environmental conditions):

- Fastener intended for use in structures subject to dry internal conditions (all materials).
- For all other conditions according to EN1993-1-4:2006+A1:2015 corresponding to corrosion resistance classes to Annex A 5 Table 5.1.

### Design:

- Fastenings are designed under the responsibility of an engineer experienced in fastenings and concrete work.
- Verifiable calculation notes and drawings are to be prepared taking account of the loads to be anchored. The position of the fastener is indicated on the design drawings (e. g. position of the fastener relative to reinforcement or to supports, etc.).
- Fastenings are designed in accordance with EN 1992-4:2018.

### Installation:

- Fastener installation is to be carried out by appropriately qualified personnel and under the supervision of the person responsible for technical matters of the site.
- Fastening depth should be marked and adhered to installation.
- Overhead installation is allowed (necessary equipment see installation instruction).

Injection system ULTRAPROFI

**Intended use**  
Specifications part 2

**Annex B2**

**Table B3.1: Installation parameters for Anchor rods / Threaded rods**

Anchor rods / Threaded rods		Thread	M6	M8	M10	M12	M16	M20	M24	M27	M30	
Nominal drill hole diameter	$d_0$	[mm]	8	10	12	14	18	24	28	30	35	
Drill hole depth	$h_0$		$h_0 \geq h_{ef}$									
Effective embedment depth	$h_{ef, min}$		50	60	60	70	80	90	96	108	120	
	$h_{ef, max}$		72	160	200	240	320	400	480	540	600	
Minimum spacing and minimum edge distance	$s_{min}$ =		40	40	45	55	65	85	105	125	140	
	$c_{min}$											
Diameter of the clearance hole of the fixture	pre-positioned installation $d_f$		7	9	12	14	18	22	26	30	33	
	push through installation $d_f$		9	12	14	16	20	26	30	33	40	
Minimum thickness of concrete member	$h_{min}$		$h_{ef} + 30 (\geq 100)$					$h_{ef} + 2d_0$				
Maximum installation torque	$\max T_{inst}$		[Nm]	5	10	20	40	60	120	150	200	300

**Anchor rod / Threaded rods**

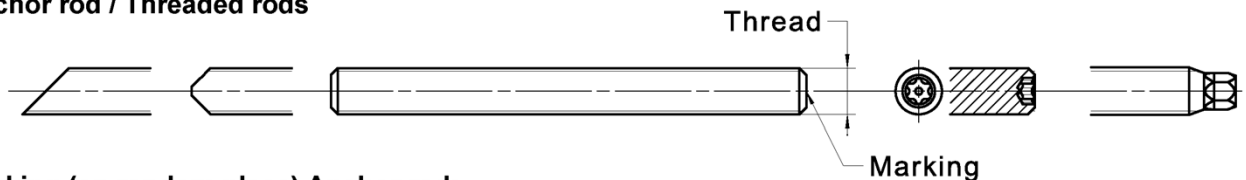

**Marking (on random place) Anchor rod:**

Steel zinc plated PC <sup>1)</sup> 8.8	• or +	Steel hot-dip PC <sup>1)</sup> 8.8	•
High corrosion resistant steel HCR PC <sup>1)</sup> 50	•	High corrosion resistant steel HCR PC <sup>1)</sup> 70	-
High corrosion resistant steel HCR PC <sup>1)</sup> 80	(	Stainless steel R property class 50 <sup>1)</sup>	~
Stainless steel R property class 80 <sup>1)</sup>	*		

Alternatively: Colour coding according to DIN 976-1: 2016

<sup>1)</sup>PC = property class

**Installation conditions:**

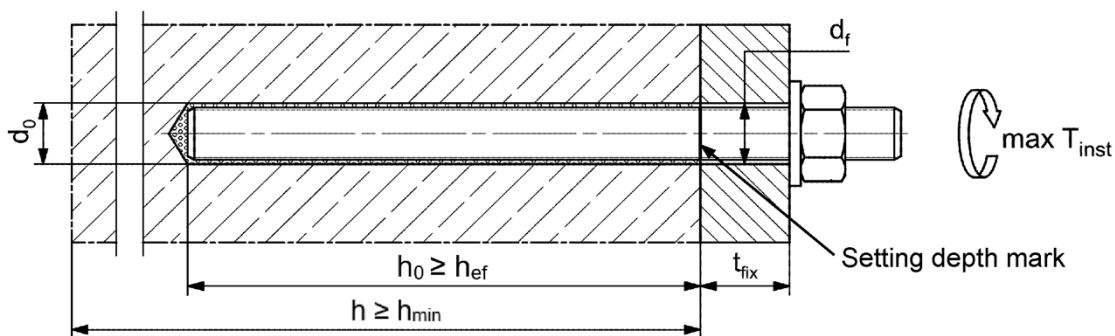

**Commercial standard threaded rods, washers and hexagon nuts may also be used if the following requirements are fulfilled:**

- Materials, dimensions and mechanical properties according to Annex A5, Table A5.1.
- Inspection certificate 3.1 according to EN 10204:2004, the documents have to be stored.
- Setting depth is marked.

Figures not to scale

Injection system ULTRAPROFI

**Intended use**  
Installation parameters Anchor rods / Threaded rods

**Annex B3**

**Table B4.1: Installation parameters for Internal threaded anchor RG M I**

RG M I		Thread	M8	M10	M12	M16	M20
Diameter of anchor	$d_{nom} = d_H$	[mm]	12	16	18	22	28
Nominal drill hole diameter	$d_0$		14	18	20	24	32
Drill hole depth	$h_0$		$h_0 \geq h_{ef} = L_H$				
Effective embedment depth ( $h_{ef} = L_H$ )	$h_{ef}$		90	90	125	160	200
Minimum spacing and minimum edge distance	$s_{min}$ = $c_{min}$		55	65	75	95	125
Diameter of clearance hole in the fixture	$d_f$		9	12	14	18	22
Minimum thickness of concrete member	$h_{min}$		120	125	165	205	260
Maximum screw-in depth	$l_{E,max}$		18	23	26	35	45
Minimum screw-in depth	$l_{E,min}$		8	10	12	16	20
Maximum installation torque	$\max T_{inst}$	[Nm]	10	20	40	80	120

**Internal threaded anchor RG M I**

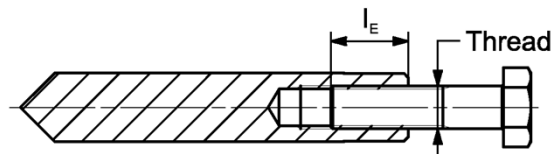
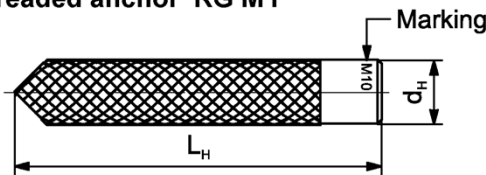

**Marking:** Anchor size e. g.: **M10**  
Stainless steel → additional **R**; e.g.: **M10 R**  
High corrosion resistant steel → additional **HCR**; e.g.: **M10 HCR**

Retaining bolt or threaded rods (including nut and washer) must comply with the appropriate material and strength class of Annex A5, Table A5.1.

**Installation conditions:**

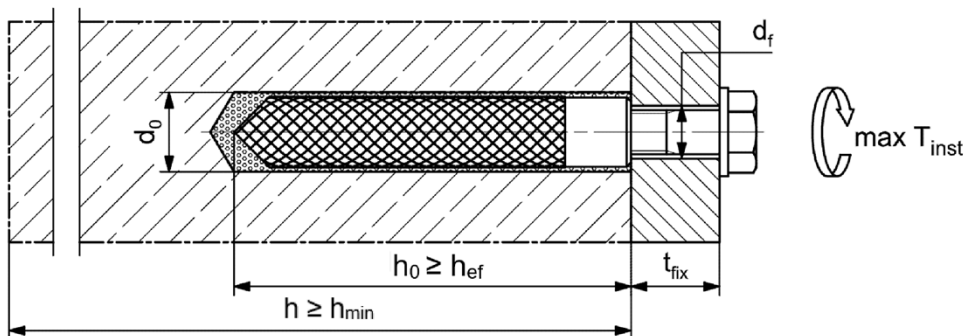

Figures not to scale

Injection system ULTRAPROFI

**Intended use**  
Installation parameters Innengewindeanker RG M I

**Annex B4**

**Table B5.1: Parameters of the cleaning brush BS  
(steel brush with steel bristles)**

The size of the cleaning brush refers to the drill hole diameter

Nominal drill hole diameter	$d_0$	[mm]	8	10	12	14	16	18	20	24	25	28	30	35
Steel brush diameter BS	$d_b$		9	11	14	16	20		25	26	27	30	40	



**Table B5.2 Maximum processing time of the mortar and minimum curing time  
(During the curing time of the mortar the concrete temperature may not fall below the listed minimum temperature)**

Temperature at anchoring base [°C]	Maximum processing time $t_{work}$			Minimum curing time $t_{cure}$ <sup>1)</sup>		
	ULTRAPROFI Installation-mortar MT High Speed	ULTRAPROFI Installation-mortar MT	ULTRAPROFI Installation-mortar MT Low Speed	ULTRAPROFI Installation-mortar MT High Speed	ULTRAPROFI Installation-mortar MT	ULTRAPROFI Installation-mortar MT Low Speed
-10 to -5 <sup>2)</sup>	> 5 min	-	-	12 h	-	-
> -5 to 0 <sup>2)</sup>	5 min	> 13 min	-	3 h	24 h	-
> 0 to 5 <sup>2)</sup>	5 min	13 min	> 20 min	3 h	3 h	6 h
> 5 to 10	3 min	9 min	20 min	50 min	90 min	3 h
> 10 to 20	1 min	5 min	10 min	30 min	60 min	2 h
> 20 to 30	-	4 min	6 min	-	45 min	60 min
> 30 to 40	-	2 min	4 min	-	35 min	30 min

<sup>1)</sup> In wet concrete or water filled holes the curing times must be doubled.

<sup>2)</sup> Minimal cartridge temperature +5°C.

Injection system ULTRAPROFI

**Intended use**  
Cleaning brush (steel brush)  
Processing time and curing time

**Annex B5**

## Installation instructions part 1

### Drilling and cleaning the hole (hammer drilling with standard drill bit)

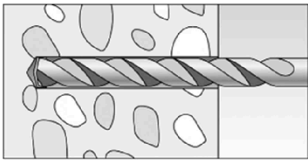
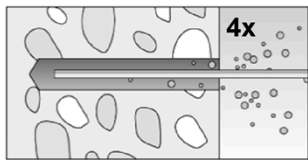
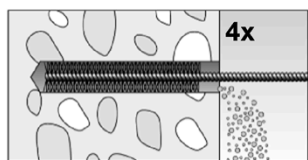
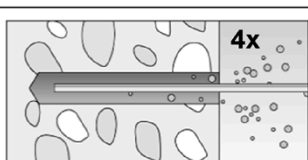
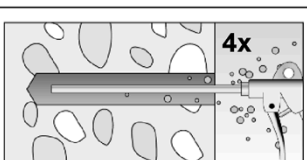
<b>1</b>		Drill the hole. Nominal drill hole diameter $d_0$ and drill hole depth $h_0$ see <b>Tables B3.1, B4.1.</b>
<b>2</b>		Clean the drill hole: For $h_{ef} \leq 12d$ and $d_0 < 18$ mm blow out the hole four times by hand.
<b>3</b>		Brush the drill hole four times. For drill hole diameter $\geq 30$ mm use a power drill. For deep holes use an extension. Corresponding brushes see <b>Table B5.1</b>
<b>4</b>		Clean the drill hole: For $h_{ef} \leq 12d$ and $d_0 < 18$ mm blow out the hole four times by hand.
		For $h_{ef} > 12d$ and / or $d_0 \geq 18$ mm blow out the hole four times with oil-free compressed air ( $p \geq 6$ bar).

Go to step 5

### Drilling and cleaning the hole (hammer drilling with hollow drill bit)

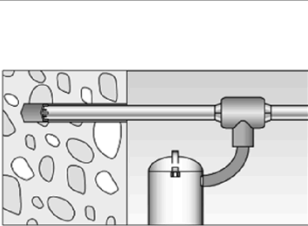
<b>1</b>		Check a suitable hollow drill (see <b>Table B1.1</b> ) for correct operation of the dust extraction.
<b>2</b>		Use a suitable dust extraction system, e.g. fischer FVC 35 M or a comparable dust extraction system with equivalent performance data.  Drill the hole with hollow drill bit. The dust extraction system has to extract the drill dust nonstop during the drilling process and must be adjusted to maximum power. Nominal drill hole diameter $d_0$ and drill hole depth $h_0$ see <b>Tables B3.1, B4.1.</b>

Go to step 5



Injection system ULTRAPROFI

**Intended use**  
Installation instructions part 1

**Annex B6**

## Installation instructions part 2

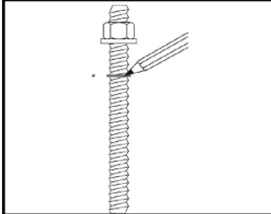
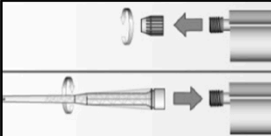
### Preparing the cartridge

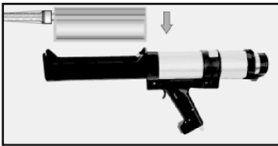
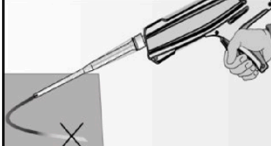
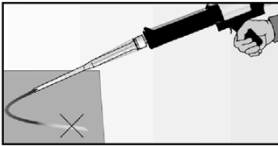
5		Mark the setting depth.
6		Remove the sealing cap. Screw on the static mixer (the spiral in the static mixer must be clearly visible).
7		 Place the cartridge into the dispenser.
8		 Extrude approximately 10 cm of material out until the resin is evenly grey in colour. Do not use mortar that is not uniformly grey.

Go to step 9

### Injection of the mortar

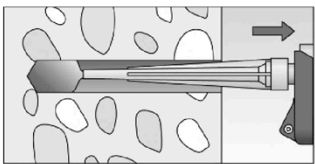
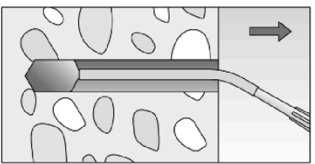
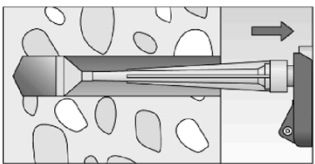
9	 <p>For <math>h_0 = h_{ef}</math> fill approximately 2/3 of the drill hole with mortar. For <math>h_0 &gt; h_{ef}</math> more mortar is needed. Always begin from the bottom of the hole and avoid bubbles.</p>	 <p>For drill hole depth <math>\geq 150</math> mm use an extension tube.</p>	 <p>For overhead installation, deep holes (<math>h_0 &gt; 250</math> mm) use an injection adapter.</p>
---	--	--	---

Go to step 10



Injection system ULTRAPROFI

**Intended use**  
Installation instructions part 2

**Annex B7**

### Installation instructions part 3

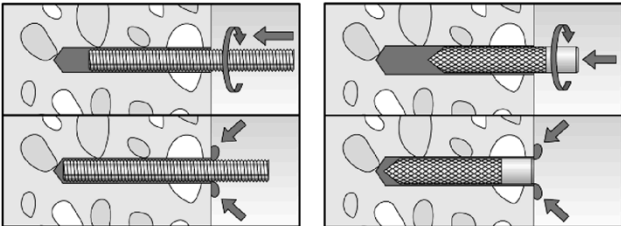
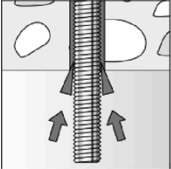
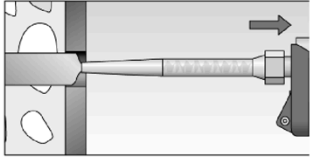
#### Installation of anchor rods or Internal threaded anchor RG M I

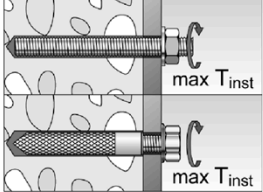
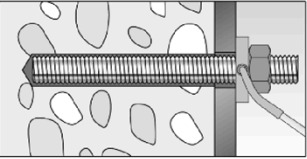
10		<p>Only use clean and oil-free metal parts. Push the anchor rod or internal threaded anchor RG M I anchor down to the bottom of the hole, turning it slightly while doing so. After inserting the metal parts, excess mortar must be emerged around the anchor element. If not, pull out the metal part immediately and reinject mortar.</p>
	 <p>For overhead installations support the metal part with wedges (e.g. centering wedges).</p>	 <p>For push through installation fill the annular gap with mortar</p>
11	 <p>Wait for the specified curing time <math>t_{cure}</math> see Table B5.2.</p>	<p>12</p>  <p>Mounting the fixture max <math>T_{inst}</math> see Tables B3.1 and B4.1.</p>
Option		<p>After the minimum curing time is reached, the gap between metal part and fixture (annular clearance) may be filled with mortar via the filling disc. Compressive strength <math>\geq 50 \text{ N/mm}^2</math> (e.g. ULTRAPROFI). ATTENTION: By using filling disc reduces <math>t_{fix}</math> (usable length of the anchor).</p>

Injection system ULTRAPROFI

Intended use  
Installation instructions part 3

Annex B8

**Table C1.1: Characteristic resistance to steel failure under tension / shear loading of Anchor rods and Threaded rods**

Anchor rod / Threaded rod		M6	M8	M10	M12	M16	M20	M24	M27	M30		
<b>Characteristic resistance to steel failure under tension loading <sup>1)</sup></b>												
Characteristic resistance $N_{Rk,s}$	Steel zinc plated	Property class 4.8	[kN]	8,0	14,6(13,2)	23,2(21,4)	33,7	62,8	98,0	141,2	183,6	224,4
		5.8		10,1	18,3(16,6)	29,0(26,8)	42,1	78,5	122,5	176,5	229,5	280,5
		8.8		16,1	29,2(26,5)	46,4(42,8)	67,4	125,6	196,0	282,4	367,2	448,8
	Stainless steel R and high corrosion resistant steel HCR	50		10,1	18,3	29,0	42,1	78,5	122,5	176,5	229,5	280,5
		70		14,1	25,6	40,6	59,0	109,9	171,5	247,1	321,3	392,7
		80		16,1	29,2	46,4	67,4	125,6	196,0	282,4	367,2	448,8
<b>Partial factors <sup>2)</sup></b>												
Partial factor $\gamma_{Ms,N}$	Steel zinc plated	Property class 4.8	[-]	1,50								
		5.8		1,50								
		8.8		1,50								
	Stainless steel R and high corrosion resistant steel HCR	50		2,86								
		70		1,87 / FIS A/RG M HCR: 1,50								
		80		1,60								
<b>Characteristic resistance to steel failure under shear loading <sup>1)</sup></b>												
<b>without lever arm</b>												
Characteristic resistance $V_{Rk,s}^0$	Steel zinc plated	Property class 4.8	[kN]	4,8	8,7(7,9)	13,9(12,8)	20,2	37,6	58,8	84,7	110,1	134,6
		5.8		6,0	10,9(9,9)	17,4(16,0)	25,2	47,1	73,5	105,9	137,7	168,3
		8.8		8,0	14,6(13,2)	23,2(21,4)	33,7	62,8	98,0	141,2	183,6	224,4
	Stainless steel R and high corrosion resistant steel HCR	50		5,0	9,1	14,5	21,0	39,2	61,2	88,2	114,7	140,2
		70		7,0	12,8	20,3	29,5	54,9	85,7	123,5	160,6	196,3
		80		8,0	14,6	23,2	33,7	62,8	98,0	141,2	183,6	224,4
Ductility factor	$k_7$	[-]	1,0									
<b>with lever arm</b>												
Charact. resistance $M_{Rk,s}^0$	Steel zinc plated	Property class 4.8	[Nm]	6,1	14,9(12,9)	29,9(26,5)	52,3	132,9	259,6	448,8	665,7	899,5
		5.8		7,6	18,7(16,1)	37,3(33,2)	65,4	166,2	324,6	561,0	832,2	1124,4
		8.8		12,2	29,9(25,9)	59,8(53,1)	104,6	265,9	519,3	897,6	1331,5	1799,0
	Stainless steel R and high corrosion resistant steel HCR	50		7,6	18,7	37,3	65,4	166,2	324,6	561,0	832,2	1124,4
		70		10,7	26,2	52,3	91,5	232,6	454,4	785,4	1165,0	1574,1
		80		12,2	29,9	59,8	104,6	265,9	519,3	897,6	1331,5	1799,0
<b>Partial factors <sup>2)</sup></b>												
Charact. resistance $M_{Rk,s}^0$	Steel zinc plated	Property class 4.8	[-]	1,25								
		5.8		1,25								
		8.8		1,25								
	Stainless steel R and high corrosion resistant steel HCR	50		2,38								
		70		1,56 / FIS A/RG M HCR: 1,25 <sup>3)</sup>								
		80		1,33								
<sup>1)</sup> Values in brackets are valid for undersized threaded rods with smaller stress area $A_s$ for hot dip galvanised Threaded rods according to EN ISO 10684:2004+AC:2009. <sup>2)</sup> In absence of other national regulations. <sup>3)</sup> Only admissible for high corrosion resist. steel HCR, with $f_{yk} / f_{uk} \geq 0,8$ and $A_5 > 12 \%$ (e.g. Anchor rods).												
Injection system ULTRAPROFI										<b>Annex C1</b>		
<b>Performances</b> Characteristic resistance to steel failure under tension / shear loading of Anchor rods and Threaded rods												

<b>Table C2.1: Characteristic resistance to steel failure under tension / shear loading of Internal threaded anchor RG M I</b>									
RG M I	RG M I	Screw		M8	M10	M12	M16	M20	
<b>Characteristic resistance to steel failure under tension loading</b>									
Characteristic resistance with screw	Property class	5.8	5.8	[kN]	18,3	29,0	42,1	78,3	122,4
			8.8		29,2	46,4	67,4	106,7	180,2
	Property class	R-70 / HCR-70	R-70 / commercial standard		25,6	40,6	59,0	109,6	171,3
			HCR-70		25,6	40,6	59,0	109,6	171,3
<b>Partial factors <sup>1)</sup></b>									
Partial factors	Property class	5.8	5.8	[-]	1,50				
			8.8		1,50				
	Property class	R-70 / HCR-70	R-70 / commercial standard		1,87				
			HCR-70		1,50				
<b>Characteristic resistance to steel failure under shear loading</b>									
<b>Without lever arm</b>									
Characteristic resistance with screw	Property class	5.8	5.8	[kN]	10,9	17,4	25,2	47,1	73,5
			8.8		14,6	23,2	33,7	62,8	98,0
	Property class	R-70 / HCR-70	R-70 / commercial standard		12,8	20,3	29,5	54,9	85,7
			HCR-70		12,8	20,3	29,5	54,9	85,7
Ductility factor			k <sub>7</sub>	[-]	1,0				
<b>With lever arm</b>									
Characteristic resistance with screw	Property class	5.8	5.8	[Nm]	18,7	37,3	65,4	166,2	324,6
			8.8		29,9	59,8	104,6	265,9	519,3
	Property class	R-70 / HCR-70	R-70 / commercial standard		26,2	52,3	91,5	232,6	454,4
			HCR-70		26,2	52,3	91,5	232,6	454,4
<b>Partial factors <sup>1)</sup></b>									
Partial factors	Property class	5.8	5.8	[-]	1,25				
			8.8		1,25				
	Property class	R-70 / HCR-70	R-70 / commercial standard		1,56				
			HCR-70		1,25				
<sup>1)</sup> In absence of other national regulations.									
Injection system ULTRAPROFI								<b>Annex C2</b>	
<b>Performances</b> Characteristic resistance to steel failure under shear loading of Internal threaded anchor RG M I									

Table C3.1: Characteristic resistance to concrete failure under tension / shear loading											
Size		All sizes									
<b>Characteristic resistance to concrete failure under tension loading</b>											
Installation factor		$\gamma_{inst}$	[-]		See annex C4 to C5						
<b>Factors for the compressive strength of concrete &gt; C20/25</b>											
Increasing factor $\psi_c$ for cracked or uncracked concrete $\tau_{Rk(X,Y)} = \psi_c \cdot \tau_{Rk(C20/25)}$	C25/30	[-]	1,05								
	C30/37		1,10								
	C35/45		1,15								
	C40/50		1,19								
	C45/55		1,22								
	C50/60		1,26								
<b>Splitting failure</b>											
Edge distance	$h / h_{ef} \geq 2,0$	$C_{cr,sp}$	[mm]	1,0 $h_{ef}$							
	$2,0 > h / h_{ef} > 1,3$			4,6 $h_{ef} - 1,8 h$							
	$h / h_{ef} \leq 1,3$			2,26 $h_{ef}$							
Spacing	$S_{cr,sp}$	2 $C_{cr,sp}$									
<b>Concrete failure</b>											
Uncracked concrete	$k_{ucr,N}$	[-]	11,0								
Cracked concrete	$k_{cr,N}$		7,7								
Edge distance	$C_{cr,N}$	[mm]	1,5 $h_{ef}$								
Spacing	$S_{cr,N}$		2 $C_{cr,N}$								
<b>Factors for sustained tension loading</b>											
Temperature range		50 °C / 80 °C				72 °C / 120 °C					
Factor		$\psi_{sus}^0$	[-]		0,74			0,87			
<b>Characteristic resistance to concrete failure under shear loading</b>											
Installation factor		$\gamma_{inst}$	[-]		1,0						
<b>Concrete pry-out failure</b>											
Factor for pry-out failure		$k_8$	[-]		2,0						
<b>Concrete edge failure</b>											
Effective length of fastener in shear loading		$l_f$	[mm]	for $d_{nom} \leq 24$ mm: min ( $h_{ef}$ , 12 $d_{nom}$ ) for $d_{nom} > 24$ mm: min ( $h_{ef}$ , 8 $d_{nom}$ ; 300 mm)							
<b>Calculation diameters</b>											
Size		M6	M8	M10	M12	M16	M20	M24	M27	M30	
Anchor rods and Threaded rods	$d_{nom}$	[mm]	6	8	10	12	16	20	24	27	30
	RG M I	$d_{nom}$	- <sup>1)</sup>	12	16	18	22	28	- <sup>1)</sup>	- <sup>1)</sup>	- <sup>1)</sup>
<sup>1)</sup> Anchor type not part of this assessment.											
Injection system ULTRAPROFI									Annex C3		
Performances Characteristic resistance to concrete failure under tension / shear loading											

<b>Table C4.1: Characteristic resistance to combined pull-out and concrete failure for Anchor rods and Threaded rods in hammer drilled holes; uncracked or cracked concrete</b>													
Anchor rod / Threaded rod		M6	M8	M10	M12	M16	M20	M24	M27	M30			
<b>Combined pull-out and concrete cone failure</b>													
Calculation diameter	d	[mm]	6	8	10	12	16	20	24	27	30		
<b>Uncracked concrete</b>													
<b>Characteristic bond resistance in uncracked concrete C20/25</b>													
<u>Hammer-drilling with standard drill bit or hollow drill bit (dry or wet concrete)</u>													
Tem- perature range	I: 50 °C / 80 °C		$\tau_{Rk,ucr}$	[N/mm <sup>2</sup> ]	9,0	11,0	11,0	11,0	10,0	9,5	9,0	8,5	8,5
	II: 72 °C / 120 °C				6,5	9,5	9,5	9,0	8,5	8,0	7,5	7,0	7,0
<u>Hammer-drilling with standard drill bit or hollow drill bit (water filled hole)</u>													
Tem- perature range	I: 50 °C / 80 °C		$\tau_{Rk,ucr}$	[N/mm <sup>2</sup> ]	- <sup>2)</sup>	- <sup>2)</sup>	- <sup>2)</sup>	9,5	8,5	8,0	7,5	7,0	7,0
	II: 72 °C / 120 °C				- <sup>2)</sup>	- <sup>2)</sup>	- <sup>2)</sup>	7,5	7,0	6,5	6,0	6,0	6,0
<b>Installation factors</b>													
Dry or wet concrete	$\gamma_{inst}$	[-]	1,0										
Water filled hole	$\gamma_{inst}$	[-]	- <sup>2)</sup>	- <sup>2)</sup>	- <sup>2)</sup>	1,2 <sup>1)</sup>							
<b>Cracked concrete</b>													
<b>Characteristic bond resistance in cracked concrete C20/25</b>													
<u>Hammer-drilling with standard drill bit or hollow drill bit (dry or wet concrete)</u>													
Tem- perature range	I: 50 °C / 80 °C		$\tau_{Rk,cr}$	[N/mm <sup>2</sup> ]	- <sup>2)</sup>	5,5	6,0	6,0	6,0	5,5	- <sup>2)</sup>	- <sup>2)</sup>	- <sup>2)</sup>
	II: 72 °C / 120 °C				- <sup>2)</sup>	4,5	5,0	6,0	6,0	5,0	- <sup>2)</sup>	- <sup>2)</sup>	- <sup>2)</sup>
<u>Hammer-drilling with standard drill bit or hollow drill bit (water filled hole)</u>													
Tem- perature range	I: 50 °C / 80 °C		$\tau_{Rk,cr}$	[N/mm <sup>2</sup> ]	- <sup>2)</sup>	- <sup>2)</sup>	- <sup>2)</sup>	5,0	5,0	4,5	- <sup>2)</sup>	- <sup>2)</sup>	- <sup>2)</sup>
	II: 72 °C / 120 °C				- <sup>2)</sup>	- <sup>2)</sup>	- <sup>2)</sup>	4,0	4,0	4,0	- <sup>2)</sup>	- <sup>2)</sup>	- <sup>2)</sup>
<b>Installation factors</b>													
Dry or wet concrete	$\gamma_{inst}$	[-]	- <sup>2)</sup>	1,0					- <sup>2)</sup>	- <sup>2)</sup>	- <sup>2)</sup>		
Water filled hole	$\gamma_{inst}$	[-]	- <sup>2)</sup>	- <sup>2)</sup>	- <sup>2)</sup>	1,2 <sup>1)</sup>			- <sup>2)</sup>	- <sup>2)</sup>	- <sup>2)</sup>		
<p>1) Valid for shuttle cartridges with 360 ml, 825 ml and coaxial cartridges with 380 ml, 400 ml, 410 ml.</p> <p>2) Performance not assessed.</p>													
Injection system ULTRAPROFI										<b>Annex C4</b>			
<b>Performances</b> Characteristic resistance to combined pull-out and concrete failure for Anchor rod and Threaded rods													

<b>Table C5.1: Characteristic resistance to combined pull-out and concrete failure for Internal threaded anchor RG M I in hammer drilled holes; uncracked concrete</b>									
<b>RG M I</b>		<b>M8</b>	<b>M10</b>	<b>M12</b>	<b>M16</b>	<b>M20</b>			
<b>Combined pull-out and concrete cone failure</b>									
Calculation diameter		d	[mm]	12	16	18	22	28	
<b>Uncracked concrete</b>									
<b>Characteristic bond resistance in uncracked concrete C20/25</b>									
<u>Hammer-drilling with standard drill bit or hollow drill bit (dry or wet concrete)</u>									
Tem- perature range	I: 50 °C / 80 °C		$\tau_{Rk,ucr}$	[N/mm <sup>2</sup> ]	10,5	10,0	9,5	9,0	8,5
	II: 72 °C / 120 °C				9,0	8,0	8,0	7,5	7,0
<u>Hammer-drilling with standard drill bit or hollow drill bit (water filled hole)</u>									
Tem- perature range	I: 50 °C / 80 °C		$\tau_{Rk,ucr}$	[N/mm <sup>2</sup> ]	10,0	9,0	9,0	8,5	8,0
	II: 72 °C / 120 °C				7,5	6,5	6,5	6,0	6,0
<b>Installation factors</b>									
Dry or wet concrete		$\gamma_{inst}$	[-]	1,0					
Water filled hole				1,2 <sup>1)</sup>					
<sup>1)</sup> Valid for shuttle cartridges with 360 ml, 825 ml and coaxial cartridges with 380 ml, 400 ml, 410 ml									
Injection system ULTRAPROFI							<b>Annex C5</b>		
<b>Performances</b> Characteristic resistance to combined pull-out and concrete failure for Internal threaded anchor RG M I									

<b>Table C6.1: Displacements for Anchor rods / Threaded rods</b>										
<b>Anchor rods / Threaded rods</b>		M6	M8	M10	M12	M16	M20	M24	M27	M30
<b>Displacement-Factors for tension loading<sup>1)</sup></b>										
<b>Uncracked concrete; Temperature range I, II</b>										
$\delta_{N0}$ -Factor	[mm/(N/mm <sup>2</sup> )]	0,09	0,09	0,09	0,10	0,10	0,10	0,10	0,11	0,12
$\delta_{N\infty}$ -Factor		0,10	0,10	0,10	0,12	0,12	0,12	0,13	0,13	0,14
<b>Cracked concrete; Temperature range I, II</b>										
$\delta_{N0}$ -Factor	[mm/(N/mm <sup>2</sup> )]	- <sup>3)</sup>	0,12	0,12	0,12	0,13	0,13	- <sup>3)</sup>	- <sup>3)</sup>	- <sup>3)</sup>
$\delta_{N\infty}$ -Factor		- <sup>3)</sup>	0,25	0,27	0,30	0,30	0,30	- <sup>3)</sup>	- <sup>3)</sup>	- <sup>3)</sup>
<b>Displacement-Factors for shear loading<sup>2)</sup></b>										
<b>Uncracked or cracked concrete; Temperature range I, II</b>										
$\delta_{V0}$ -Factor	[mm/kN]	0,11	0,11	0,11	0,10	0,10	0,09	0,09	0,08	0,07
$\delta_{V\infty}$ -Factor		0,12	0,12	0,12	0,11	0,11	0,10	0,10	0,09	0,09
<sup>1)</sup> Calculation of effective displacement: $\delta_{N0} = \delta_{N0}\text{-Factor} \cdot \tau$ $\delta_{N\infty} = \delta_{N\infty}\text{-Factor} \cdot \tau$ $\tau$ = acting bond strength under tension loading					<sup>2)</sup> Calculation of effective displacement: $\delta_{V0} = \delta_{V0}\text{-Factor} \cdot V$ $\delta_{V\infty} = \delta_{V\infty}\text{-Factor} \cdot V$ $V$ = acting shear loading					
<sup>3)</sup> Performance not assessed										
<b>Table C6.2: Displacements for Internal threaded anchor RG M I</b>										
<b>RG M I</b>		M8	M10	M12	M16	M20				
<b>Displacement-Factors for tension loading<sup>1)</sup></b>										
<b>Uncracked concrete; Temperature range I, II</b>										
$\delta_{N0}$ -Factor	[mm/(N/mm <sup>2</sup> )]	0,10	0,11	0,12	0,13	0,14				
$\delta_{N\infty}$ -Factor		0,13	0,14	0,15	0,16	0,18				
<b>Displacement-Factors for shear loading<sup>2)</sup></b>										
<b>Uncracked concrete; Temperature range I, II</b>										
$\delta_{V0}$ -Factor	[mm/kN]	0,12	0,12	0,12	0,12	0,12				
$\delta_{V\infty}$ -Factor		0,14	0,14	0,14	0,14	0,14				
<sup>1)</sup> Calculation of effective displacement: $\delta_{N0} = \delta_{N0}\text{-Factor} \cdot \tau$ $\delta_{N\infty} = \delta_{N\infty}\text{-Factor} \cdot \tau$ $\tau$ = acting bond strength under tension loading					<sup>2)</sup> Calculation of effective displacement: $\delta_{V0} = \delta_{V0}\text{-Factor} \cdot V$ $\delta_{V\infty} = \delta_{V\infty}\text{-Factor} \cdot V$ $V$ = acting shear loading					
<b>Injection system ULTRAPROFI</b>							<b>Annex C6</b>			
<b>Performances</b> Displacements for Anchor rods / Threaded rods and Internal threaded anchor RG M I										