

Public-law institution jointly founded by the
federal states and the Federation

European Technical Assessment Body
for construction products



European Technical Assessment

ETA-20/0387
of 1 April 2026

English translation prepared by DIBt - Original version in German language

General Part

Technical Assessment Body issuing the
European Technical Assessment:

Deutsches Institut für Bautechnik

Trade name of the construction product

Max Frank Coupler

Product family
to which the construction product belongs

Couplers for mechanical splices of reinforcing steel bars

Manufacturer

Max Frank GmbH & Co KG
Mitterweg 1
94339 Leiblfing
DEUTSCHLAND

Manufacturing plant

Max Frank GmbH & Co. KG
Mittlerweg 1
94339 Leiblfing
DEUTSCHLAND

This European Technical Assessment
contains

14 pages including 3 annexes which form an integral part
of this assessment

This European Technical Assessment is
issued in accordance with Article 95(4) of
Regulation (EU) 2024/3110, on the basis of

EAD 160129-01-0301

This version replaces

ETA-20/0387 issued on 2 January 2025

The European Technical Assessment is issued by the Technical Assessment Body in its official language. Translations of this European Technical Assessment in other languages shall fully correspond to the original issued document and shall be identified as such.

Communication of this European Technical Assessment, including transmission by electronic means, shall be in full. However, partial reproduction may only be made with the written consent of the issuing Technical Assessment Body. Any partial reproduction shall be identified as such.

This European Technical Assessment may be withdrawn by the issuing Technical Assessment Body, in particular pursuant to information by the Commission in accordance with Article 36(3) of Regulation (EU) No 2024/3110.

Specific Part

1 Technical description of the product

The Max Frank Coupler is used as a mechanical, screwed system for connecting reinforcing bars in reinforced concrete components under static or quasi-static, fatigue and low cycle loading.

The product description is given in Annex A.

The characteristic material values, dimensions and tolerances of the Max Frank Coupler not indicated in Annexes A1 to A4 shall correspond to the respective values laid down in the technical documentation^[1] of this European technical assessment.

2 Specification of the intended use in accordance with the applicable European Assessment Document

The performances given in Section 3 are only valid if the Max Frank Coupler is used in compliance with the specifications and conditions given in Annex B.

The verifications and assessment methods on which this European Technical Assessment is based lead to the assumption of a working life of the Max Frank Coupler of at least 100 years. The indications given on the working life cannot be interpreted as a guarantee given by the producer, but are to be regarded only as a means for choosing the right products in relation to the expected economically reasonable working life of the works.

3 Performance of the product and references to the methods used for its assessment

3.1 Mechanical resistance and stability (BWR 1)

Essential characteristic	Performance
Resistance to static or quasi-static loading	See Annex C1 – C3
Slip under static or quasi-static load	See Annex C1 – C3
Slip after static or quasi-static load	See Annex C1 – C3
Fatigue strength for $N = 2 \cdot 10^6$ load cycles	No performance assessed
Fatigue strength for S-N curve with k_1 and k_2 according to EN 1992-1-1	No performance assessed
Fatigue strength for S-N curve with specific k_1 and k_2	See Annex C2 and C3
Resistance to low cycle loading (seismic actions)	See Annex C1

3.2 Safety in case of fire (BWR 2)

Essential characteristic	Performance
Reaction to fire	Class A1

^[1] The technical documentation of this European technical assessment is deposited at the Deutsches Institut für Bautechnik and, as far as relevant for the tasks of the approved bodies involved in the attestation of conformity procedure, is handed over to the approved bodies.

4 Assessment and verification of constancy of performance (AVCP) system applied, with reference to its legal base

In accordance with EAD 160129-01-0301 the applicable European legal act is: 2000/606/EC.
The system to be applied is: 1+

5 Technical details necessary for the implementation of the AVCP system, as provided for in the applicable EAD

Technical details necessary for the implementation of the AVCP system are laid down in the control plan deposited with Deutsches Institut für Bautechnik.

The following standards are referred to in this European Technical Assessment:

EN ISO 683-1:2018	Heat-treatable steels, alloy steels and free-cutting steels – Part 1: Non-alloy steels for quenching and tempering (ISO 683-1:2016)
EN ISO 683-2:2018	Heat-treatable steels, alloy steels and free-cutting steels – Part 2: Alloy steels for quenching and tempering (ISO 683-2:2016)
EN 1992-1-1:2004 + AC:2010 + A1:2014	Eurocode 2: Design of concrete structures - Part 1-1: General rules and rules for buildings
EN 1998-1:2004 + AC:2009 + A1:2013	Eurocode 8: Design of structures for earthquake resistance – Part 1: General rules, seismic actions and rules for buildings
EN ISO 6789-2:2017	Assembly tools for screws and nuts - Hand torque tools – Part 2: Requirements for calibration and determination of measurement uncertainty (ISO 6789-2:2017)
GB/T 3077:2015	Alloy structure steels

Issued in Berlin on 1 April 2026 by Deutsches Institut für Bautechnik

Dipl.-Ing. Beatrix Wittstock
Head of Section

beglaubigt:
Kisan

A.1 Type overview Max Frank Coupler

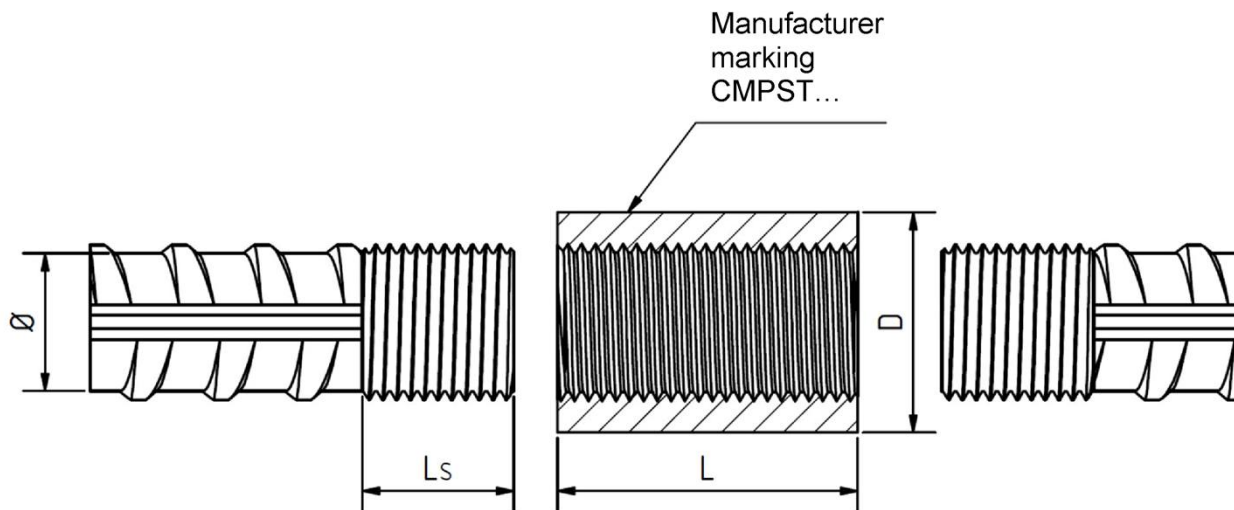

Figure A 1 Standard Coupler

Table A 1 Dimensions Standard Coupler

Rebar nominal diameter \varnothing [mm]	Coupler external diameter D [mm]	Coupler length L [mm]	Screw-in depth L_s [mm]	Thread dimensions [mm]	Torque [mm]
12	20	28	14	M14,0 x 2,0	40
14	23	32	16	M16,0 x 2,0	80
16	26	36	18	M18,5 x 2,0	120
18	28,5	40	20	M20,5 x 2,0	150
20	32	44	22	M22,5 x 2,0	180
20	32	48	24	M24,0 x 3,0	180
22	34,5	48	24	M24,5 x 2,5	220
24	38	54	27	M27,5 x 2,5	270
25	38	54	27	M27,5 x 2,5	270
26	38	54	27	M27,5 x 2,5	270
28	42	60	30	M30,5 x 2,5	270
32	48	58	34	M34,5 x 2,5	300
36	56,5	78	39	M39,5 x 3,0	300
40	61	85	42,5	M43,5 x 3,0	350

Max Frank Coupler

Annex A 1

Product description – Standard Coupler

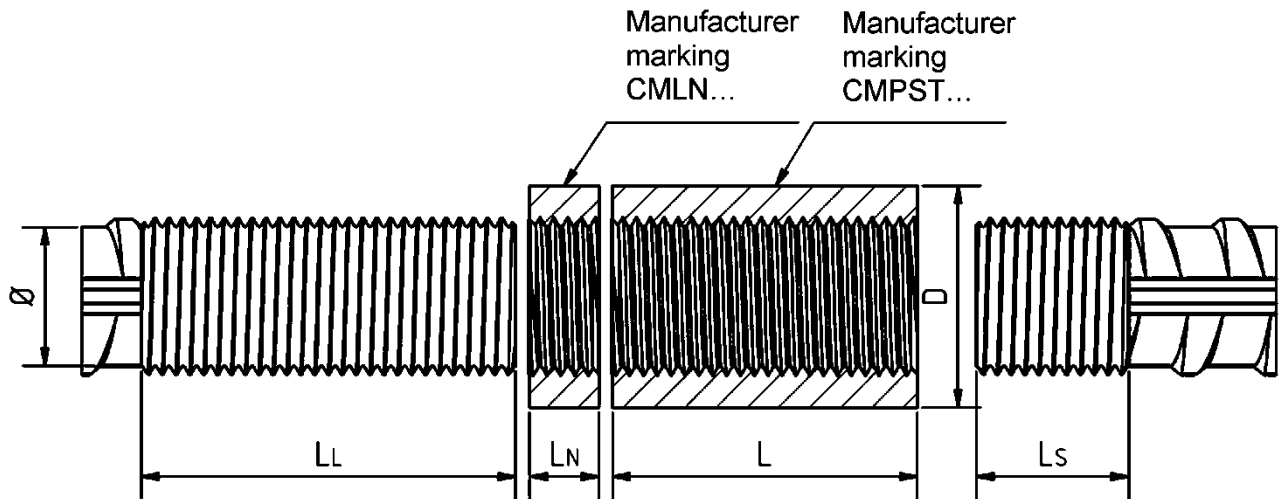

Figure A 2 Positional Coupler

Table A 2 Dimensions Positional Coupler

Rebar nominal diameter \varnothing [mm]	Coupler external diameter D [mm]	Coupler length L [mm]	Screw-in depth L_S [mm]	Thread length L_L [mm]	Nut length L_N [mm]	Thread dimensions [mm]	Torque [Nm]
12	20	28	14	37	9	M14,0 x 2,0	40
14	23	32	16	41	9	M16,0 x 2,0	80
16	26	36	18	45	9	M18,5 x 2,0	120
18	28,5	40	20	49	9	M20,5 x 2,0	150
20	32	44	22	53	9	M22,5 x 2,0	180
22	34,5	48	24	57	9	M24,5 x 2,0	220
24	38	54	27	67	13	M27,5 x 2,5	270
25	38	54	27	67	13	M27,5 x 2,5	270
26	38	54	27	67	13	M27,5 x 2,5	270
28	42	60	30	73	13	M30,5 x 2,5	270
32	48	68	34	81	13	M34,5 x 2,5	300
36	56,5	78	39	91	13	M39,5 x 3,0	300
40	61	85	42,5	98	13	M43,5 x 3,0	350

Max Frank Coupler

Product description – Positional Coupler

Annex A 2

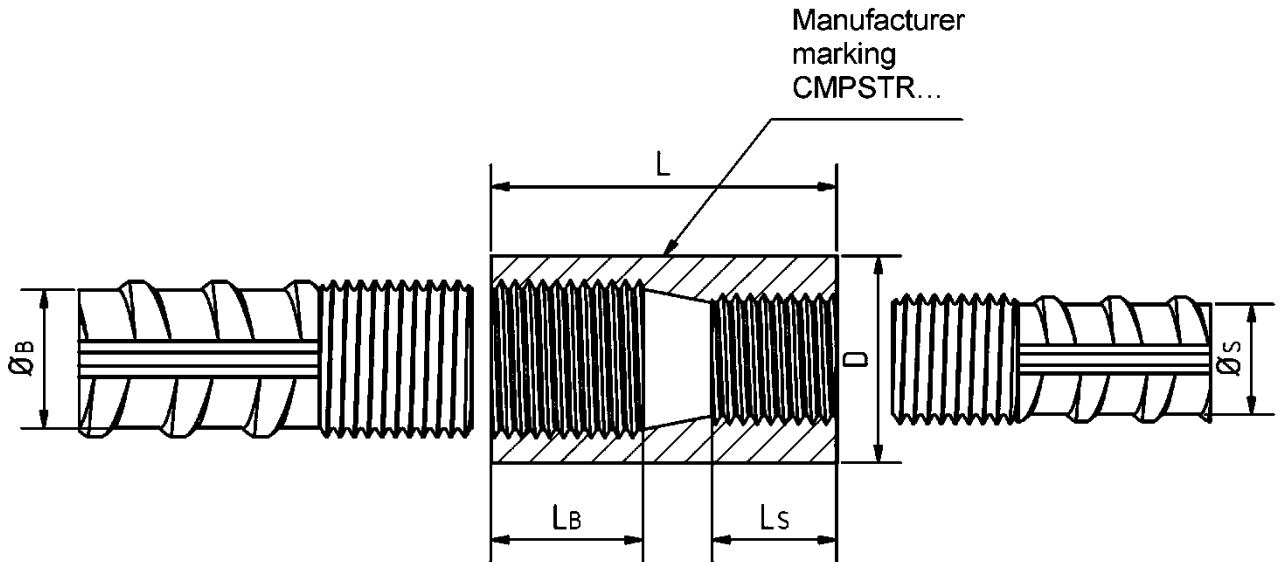

Figure A 3 Transition Couplers

Table A 3 Dimensions Transition Couplers

Rebar nominal diameter \varnothing_B bar B [mm]	Rebar nominal diameter \varnothing_S bar S [mm]	Coupler external diameter D [mm]	Coupler length L [mm]	Screw-in depth L_B [mm]	Screw-in depth L_S [mm]	Thread dimensions bar B [mm]	Thread dimensions bar S [mm]	Torque bar B [Nm]	Torque bar S [Nm]
14	12	23	35	16	14	M16,0 x 2,0	M14,0 x 2,0	80	40
16	14	26	39	18	16	M18,5 x 2,0	M16,0 x 2,0	120	80
18	16	28,5	43	20	18	M20,5 x 2,0	M18,5 x 2,0	150	120
20	16	32	45	22	18	M22,5 x 2,0	M18,5 x 2,0	180	120
20	18	32	47	22	20	M22,5 x 2,0	M20,5 x 2,0	180	150
22	20	34,5	51	24	22	M24,5 x 2,0	M22,5 x 2,0	220	180
22	18	34,5	49	24	20	M24,5 x 2,0	M20,5 x 2,0	220	150
25	22	38	56	27	24	M27,5 x 2,5	M24,5 x 2,0	270	220
25	20	38	54	27	22	M27,5 x 2,5	M22,5 x 2,0	270	180
28	25	42	64	30	27	M30,5 x 2,5	M27,5 x 2,5	270	270
28	22	42	61	30	24	M30,5 x 2,5	M24,5 x 2,0	270	220
28	20	42	59	30	22	M30,5 x 2,5	M22,5 x 2,0	270	180
32	28	48	71	34	30	M34,5 x 2,5	M30,5 x 2,5	300	270
32	25	48	68	34	27	M34,5 x 2,5	M27,5 x 2,5	300	270
36	32	56,5	80	39	34	M39,5 x 3,0	M34,5 x 2,5	300	300
36	28	56,5	76	39	30	M39,5 x 3,0	M30,5 x 2,5	300	270
40	36	61	89	43	39	M43,5 x 3,0	M39,5 x 3,0	350	300
40	32	61	84	43	34	M43,5 x 3,0	M34,5 x 2,5	350	300
40	28	61	80	43	30	M43,5 x 3,0	M30,5 x 2,5	350	270

Max Frank Coupler

Product description – Transition Coupler

Annex A 3

A.2 Materials

Sleeve steel: 40Cr according to GB/T 3077,
1.7035, 1.7039, 1.7225 or 1.7227 according to EN ISO 683-2,
and C45, 1.0503 to EN ISO 683-1 as an alternative for the transition Coupler
according to deposited technical specification in each case Class A1 according to
EN 13501-1

Reinforcing steel: B450C, B500B or B500C

Max Frank Coupler

Product description – Materials

Annex A 4

B.1 Intended use

Max Frank Couplers are used as mechanical coupling in accordance with EN 1992-1-1 and EN 1998-1 and annex C for reinforcing steel bars B450C, B500B and B500C with a nominal diameter of 12 to 40 mm in accordance with EN 1992-1-1, clause C.1 for:

- Transmission of static or quasi static tension and compression loads according to EN 1992-1-1, clauses 8.7 and 8.8 (4),
- Limitation of slip according to EN 1992-1-1, clause 7.3,
- Transmission of high-cycle fatigue loads with fatigue resistance according to EN 1992-1-1, clause 6.8.4,
- Resistance to low-cycle seismic loading according to EN 1998-1, clause 5.6.3 (2).

The rebar connection is primarily used for force transmission in construction joints.

The “Max Frank Coupler” system allows the following rebar coupling variants:

- Standard coupler where the connecting rebar can move along the axis and rotate freely,
- Positional coupler where the movement of the connecting bar is restricted (e.g. cannot be rotated because bent or offset and/or cannot move along the axis),
- Transition coupler for connecting rebars with different nominal diameters.

The screw couplers have metric internal threads. The bar ends to be connected are provided with metric external threads.

The bar ends are screwed into the internal threads of the couplers and locked in the coupling threads to a specified torque to reduce the slip.

Max Frank Coupler

Intended use – design

Annex B 1

B.2 Installation requirements

- Joints may be subjected to 100% of the static and quasi-static tensile and compressive load in the same way as non-lapped bar, DIN EN 1992-1-1, Section 8.7.2(4) applies.
- The same values as for non-lapped bars shall apply to the concrete cover over the outer edge of a coupler, an anchoring element or a nut as well as to the clear distances between the outer edges of adjacent couplers, anchoring elements and nuts in accordance with EN 1992-1-1, clauses 4.4.1 and 8.2. The spacing necessary for installation shall remain unaffected.
- For bent (pre-bent) bars, the intentional bending shall not begin until a distance of at least $5 \varnothing$ from the coupling end (\varnothing = nominal diameter of the bent bar). If coupling bars are bent at the manufacturing plant with special equipment, the distance to the coupling end may be reduced to $2 \varnothing$.
- The couplers and anchorages shall only be installed by trained staff in accordance with the manufacturer's written work instructions. These installation instructions are part of the accompanying documents.
- Only coupling elements that are marked in accordance with annex A shall be used.
- The required displacement and rotation of the bars shall be given.
- The threads of the bars and coupling elements shall be free of rust and contamination.
- Only torque tools whose functionality and precision have been tested in accordance with EN ISO 6789-2 shall be used for tightening the screw coupler connections. The torque to be applied is given in annexes A. The torque wrench shall be checked before and during use to ensure compliance with the requirements.

Max Frank Coupler

Intended use – installation requirements

Annex B 2

Installation manual

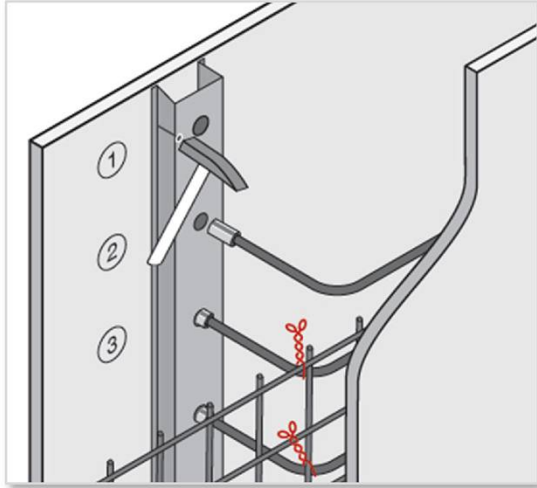

Fixing of Coupler bars in the first construction stage, e.g. as shown with mounting box on the formwork.

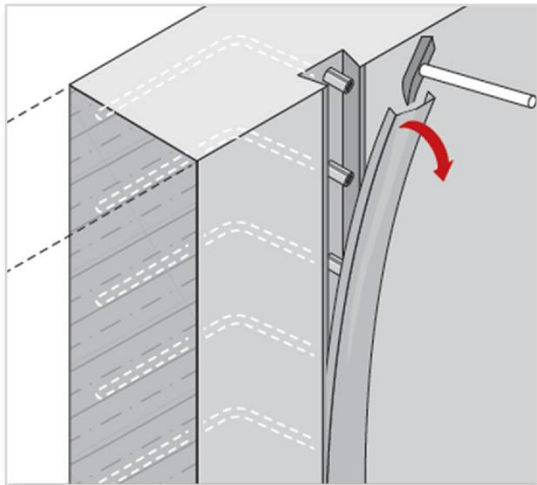

Stripping the formwork and opening the mounting box

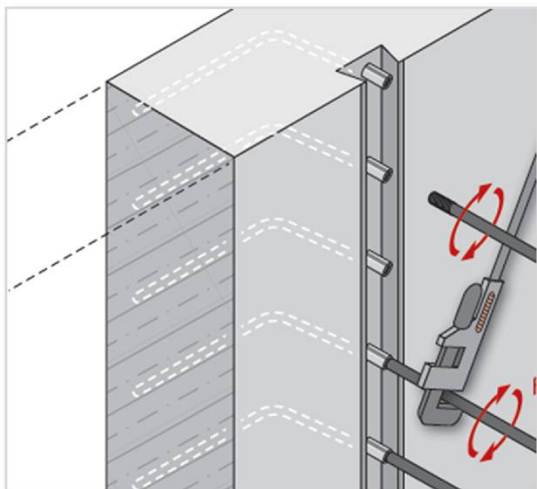

Screwing in the bars of the second construction stage and applying the necessary torque.

Max Frank Coupler

Intended use – installation requirements

Annex B 3

C.1 Performance parameters

C.1.1 Connection with reinforcing steel B450C

Nominal diameter \varnothing [mm]	Resistance to static or quasi-static loading (tension and compression) ¹⁾ $f_{u,min,bar,outside}$ [N/mm ²]	Slip under static or quasi-static loading ²⁾ s_1 [mm]	Slip under static or quasi-static loading ³⁾ s_2 [mm]	Resistance to seismic actions ⁴⁾	
				u_{20} [mm]	$F_{u,min}$ [kN]
12	518	0,1	0,1	0,3	58,6
14					79,7
16					104,2
18					131,8
20					162,7
22					196,9
24					234,3
25					254,3
26					275,0
28					319,0
32					416,6
36					527,3
40					650,9

¹⁾ $f_{u,min,bar,outside} = f_{yk} \cdot 1,15$ with $f_{yk} = 450 \text{ N/mm}^2$

²⁾ Slip within the connection under loading measured at $0,6 \cdot f_{yk}$

³⁾ Slip within the connection after loading measured at $0,02 \cdot f_{yk}$

⁴⁾ $F_{u,min} = \left(\frac{\pi \cdot \varnothing^2}{4}\right) \cdot f_{u,min}$

Max Frank Coupler

Annex C 1

Performance parameters for connections with B450C

C.1.2 Connection with reinforcing steel B500B

Nominal diameter \varnothing [mm]	Resistance to static or quasi-static loading (tension and compression) ¹⁾ $f_{u,min,bar,outside}$ [N/mm ²]	Slip under static or quasi-static loading ²⁾ s_1 [mm]	Slip after static or quasi-static loading ³⁾ s_2 [mm]	Fatigue strength for S-N curve with specific k_1 und k_2 with $N^*=10^7$		
				$\Delta\sigma_{Rsk}$ [N/mm ²]	k_1 [-]	k_2 [-]
12	540	0,1	0,1	78 ($N = 2 \cdot 10^6$)	3	5
14						
16						
18						
20						
22						
24						
25						
26						
28						
32				68 ($N = 2 \cdot 10^6$)	2	3
36						
40						

¹⁾ $f_{u,min,bar,outside} = f_{yk} \cdot 1,08$ with $f_{yk} = 500$ N/mm²

²⁾ Slip within the connection under loading measured at $0,6 \cdot f_{yk}$

³⁾ Slip within the connection after loading measured at $0,02 \cdot f_{yk}$

Max Frank Coupler

Annex C 2

Performance parameters for connections with B500B

C.1.3 Connection with reinforcing steel B500C

Nominal diameter \varnothing [mm]	Resistance to static or quasi-static loading (tension and compression) ¹⁾ $f_{u,min,bar,outside}$ [N/mm ²]	Slip under static or quasi-static loading ²⁾ s_1 [mm]	Slip after static or quasi-static loading ³⁾ s_2 [mm]	Fatigue strength for S-N curve with specific k_1 und k_2 with $N^*=10^7$		
				$\Delta\sigma_{Rsk}$ [N/mm ²]	k_1 [-]	k_2 [-]
12	575	0,1	0,1	78 ($N = 2 \cdot 10^6$)	3	5
14						
16						
18						
20						
22						
24				68 ($N = 2 \cdot 10^6$)	2	3
25						
26						
28						
32						
36						
40						

¹⁾ $f_{u,min,bar,outside} = f_{yk} \cdot 1,15$ with $f_{yk} = 500$ N/mm²

²⁾ Slip within the connection under loading measured at $0,6 \cdot f_{yk}$

³⁾ Slip within the connection after loading measured at $0,02 \cdot f_{yk}$

Max Frank Coupler

Performance parameters for connections with B500C

Annex C 3