

Public-law institution jointly founded by the federal states and the Federation

European Technical Assessment Body
for construction products

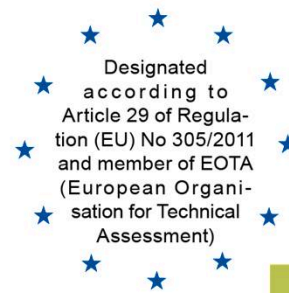

European Technical Assessment

ETA-21/0439
of 31 March 2026

English translation prepared by DIBt - Original version in German language

General Part

Technical Assessment Body issuing the European Technical Assessment:

Deutsches Institut für Bautechnik

Trade name of the construction product

Schöck Stacon® type SLD and SLD-Q

Product family to which the construction product belongs

Dowels for structural joints under static and quasi-static loading

Manufacturer

Schöck Bauteile GmbH
Schöckstraße 1
76534 Baden-Baden
GERMANY

Manufacturing plant

Schöck Bauteile GmbH
Schöckstraße 1
76534 Baden-Baden
Schöck Hungaria Kft., Külterület 017/55 hrsz., 2721, Pilis, Hungary

This European Technical Assessment contains

16 pages including 3 annexes which form an integral part of this assessment

This European Technical Assessment is issued in accordance with Article 95(4) of Regulation (EU) No 2024/3110, on the basis of

EAD 050019-00-0301

This version replaces

ETA-21/0439 issued on 20 December 2024

The European Technical Assessment is issued by the Technical Assessment Body in its official language. Translations of this European Technical Assessment in other languages shall fully correspond to the original issued document and shall be identified as such.

Communication of this European Technical Assessment, including transmission by electronic means, shall be in full. However, partial reproduction may only be made with the written consent of the issuing Technical Assessment Body. Any partial reproduction shall be identified as such.

This European Technical Assessment may be withdrawn by the issuing Technical Assessment Body, in particular pursuant to information by the Commission in accordance with Article 36(3) of Regulation (EU) No 2024/3110.

Specific Part

1 Technical description of the product

The dowel type SLD consists of a dowel bar with a diameter of 20 mm to 45 mm and a round tube welded on a rectangular front plate with welded hangers for anchoring in concrete members. The embedment depth of the dowel in the concrete member is 5.0 times the bar diameter. All parts of the dowel with a concrete cover less than 30 mm are made of stainless steel with one of the following material numbers 1.4362, 1.4482, 1.4462, 1.4404, or 1.4571. according to EN 10088-2 and EN 10088-3.

The round dowel bars are made of stainless steel with yield strength of 750 N/mm² for diameters 20 to 22 mm and 690 N/mm² for diameters 25 to 45 mm.

The dowel type SLD-Q consists of a quadratic dowel bar with dimensions 20 mm x 20 mm to 40 mm x 40 mm and a rectangular tube welded on a rectangular front plate with welded hangers for anchorage in concrete members. This sleeve with rectangular tube allows horizontal movement of the dowel across the dowel axis. The embedment depth of the dowel in the concrete member is 5.0 times the bar diameter. All parts of the dowel with a concrete cover less than 30 mm are made of stainless steel with one of the following material numbers 1.4362, 1.4482, 1.4462, 1.4404 or 1.4571 according to EN 10088-2 and EN 10088-3.

The rectangular dowel bars are made of stainless steel with yield strength of 750 N/mm².

Optionally, the fire protection collar type SLD-BSM can be part of the dowel. This collar consists of a 2,5 mm Promaseal PL fire protection plate and mineral fibre board. The mineral fibre board is classified as A1 according to EN 13501-1. In the case of fire the Promaseal PL plate foams up and closes the joint near the dowel in order to insulate the dowel from the flames.

The detailed product description is given in Annex A.

The characteristic material values, dimensions and tolerances of the dowels not indicated in Annexes A1 to A4 shall correspond to the respective values laid down in the technical documentation^[1] of this European Technical Assessment.

2 Specification of the intended use in accordance with the applicable European Assessment Document

The performances given in Section 3 are only valid if the Product is used in compliance with the specifications and conditions given in Annex B.

The verifications and assessment methods on which this European Technical Assessment is based lead to the assumption of a working life of the Product of at least 50 years. The indications given on the working life cannot be interpreted as a guarantee given by the producer, but are to be regarded only as a means for choosing the right products in relation to the expected economically reasonable working life of the works.

^[1] The technical documentation of this European technical approval is deposited at the Deutsches Institut für Bautechnik and, as far as relevant for the tasks of the approved bodies involved in the attestation of conformity procedure, is handed over to the approved bodies.

3 Performance of the product and references to the methods used for its assessment

3.1 Mechanical resistance and stability (BWR 1)

Essential characteristic	Performance
Resistance to steel failure at ULS for SLD	$e = 0,7 \text{ mm}$
Resistance to steel failure at ULS for SLD-Q	$e = 4,2 \text{ mm}$
Resistance to concrete edge failure at ULS not influenced by lateral movements of the dowel	$X_{1,1} = 0,38$
	$B_{\text{spec},1}$ [mm] Annex C1, Table 6
	$H_{\text{spec},1}$ Annex C1, Table 6
Resistance to concrete edge failure at ULS influenced by lateral movements of the dowel	$k_{1,1} = 0$
	$X_{1,2} = 0,38$
	$B_{\text{spec},2}$ [mm] Annex C1, Table 6
Resistance to concrete edge failure at SLS	$H_{\text{spec},2}$ Annex C1, Table 6
	$k_{1,2} = 0$
Resistance to concrete edge failure at SLS	$X_2 = 0,53$
Resistance to steel failure at SLS	$X_3 = 0,27$

3.2 Safety in case of fire (BWR 2)

Essential characteristic	Performance
Reaction to fire	class A1
Resistance to fire	Annex C2

4 Assessment and verification of constancy of performance (AVCP) system applied, with reference to its legal base

In accordance with EAD No. 050019-00-0301 the applicable European legal act is: [2003/639/EC(EU)].

The system(s) to be applied is (are): [2+], for reaction to fire [4]

5 Technical details necessary for the implementation of the AVCP system, as provided for in the applicable EAD

Technical details necessary for the implementation of the AVCP system are laid down in the control plan deposited with Deutsches Institut für Bautechnik.

Reference Documents

EN 10088-2:2025	Stainless steels - Part 2: Technical delivery conditions for sheet/plate and strip of corrosion resistant steels for general purposes
EN 10088-3:2014	Stainless steels - Part 3: Technical delivery conditions for semi-finished products, bars, rods, wire, sections and bright products of corrosion resisting steels for general purposes
EN 13162:2012+A1:2015	Thermal insulation products for buildings - Factory made mineral wool (MW) products - Specification
EN 13501-1: 2019-05	Fire classification of construction products and building elements - Part 1: Classification using data from reaction to fire tests
EN 1992-1-1:2004 + AC:2010	Design of concrete - Part 1 -1: General rules and rules for buildings
EN 1992-1-2:2004 + AC:2008	Design of concrete - Part 1 -2: General rules - Structural fire design
EN 1993-1-2:2005 + AC:2009	Design of steel structures - Part 1 - 2: General rules - Structural fire design
EN 1993-1-4:2006 + A1:2015	Design of steel structures - Part 1 - 4: General rules – Supplementary rules for stainless steels
EN 206:2013 + A1:2016	Concrete - Specification, performance, production and conformity
EOTA TR 065:2019-10-31	Design of structural joints with shear dowels
ETA-18/0198	PROMASEAL®-PL Intumescent product for fire sealing and fire stopping purposes, 20. June 2018

Issued in Berlin on 31 March 2026 by Deutsches Institut für Bautechnik

Dipl.-Ing. Beatrix Wittstock
Head of Section

beglaubigt:
Hoffmeister

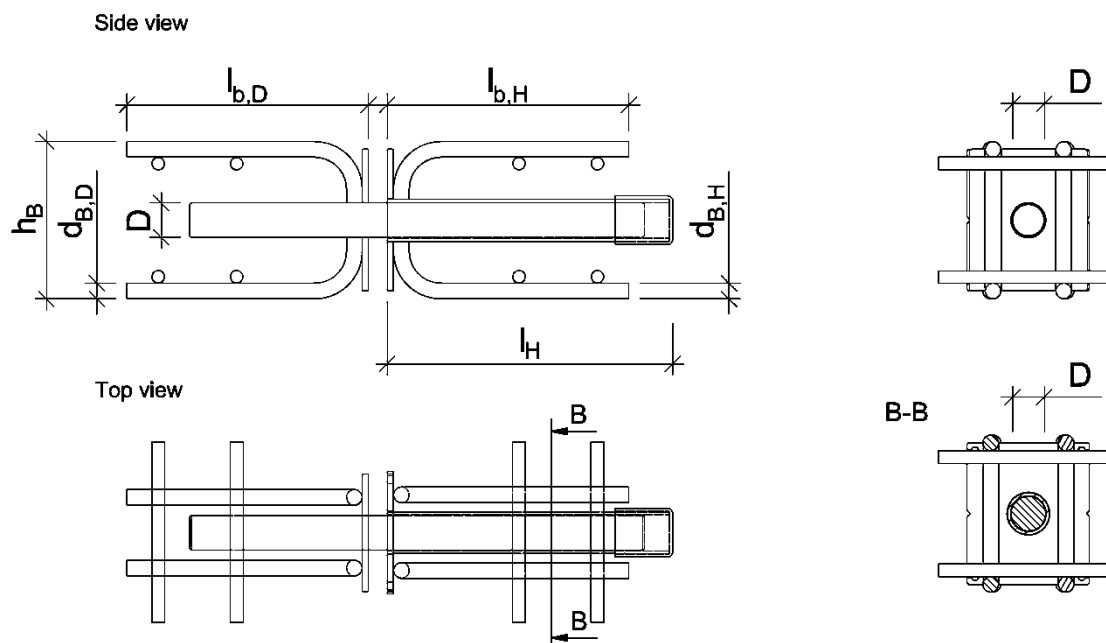

Fig. 1: Stacon type SLD

Tab. 1: Dimensions of Stacon type SLD

Stacon type	D	n x d_B	n x d_H	h_B	$l_{b,D}$	$l_{b,H}$	l_H
	[mm]	[mm]	[mm]	[mm]	[mm]	[mm]	[mm]
SLD 200	20	2 x 10	2 x 10	100	154	154	170
SLD 220	22	2 x 10	2 x 10	100	154	154	180
SLD 250	25	2 x 12	2 x 12	120	184	184	195
SLD 270	27	2 x 12	2 x 12	130	206	206	205
SLD 300	30	2 x 14	2 x 14	140	216	216	220
SLD 350	35	4 x 12	4 x 12	170	258	258	245
SLD 400	40	2 x 14	2 x 14	200	348	348	270
SLD 450	45	4 x 14	4 x 14	230	400	400	295

The Stacon type SLD is tested and evaluated for joint widths from 10-80 mm. The standard product range of the type SLD is designed for joint widths of 10 – 60 mm.

Schöck Stacon type SLD

Product description
Dimensions of type SLD

Annex A1

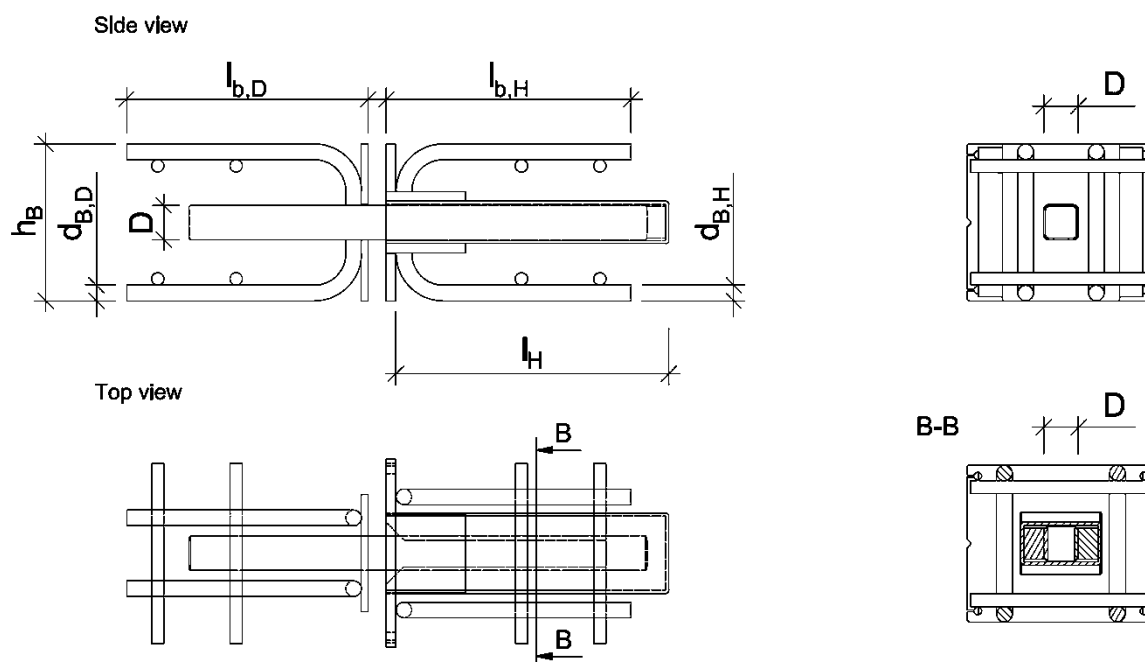

Fig. 2: Stacon type SLD-Q

Tab. 2: Dimensions of Stacon type SLD-Q

Stacon type	D	n x d _B	n x d _H	h _B	l _{b,D}	l _{b,H}	l _H
	[mm]	[mm]	[mm]	[mm]	[mm]	[mm]	[mm]
SLD-Q 200	20	2 x 10	2 x 10	100	154	156	170
SLD-Q 220	22	2 x 10	2 x 10	100	154	156	180
SLD-Q 250	25	2 x 12	4 x 12	120	186	188	195
SLD-Q 270	27	2 x 12	4 x 12	130	206	208	205
SLD-Q 300	30	2 x 14	4 x 12	140	216	218	220
SLD-Q 350	35	4 x 12	4 x 12	170	258	260	245
SLD-Q 400	40	4 x 14	4 x 14	200	350	350	270

The Stacon type SLD is tested and evaluated for joint widths from 10-80 mm. The standard product range of the type SLD is designed for joint widths of 10 – 60 mm.

Schöck Stacon type SLD-Q

Product description
Dimensions of type SLD-Q

Annex A2

Tab. 3: Materials of the components of Stacon type SLD and SLD-Q

Product part	Material number
Dowel Stacon type SLD and SLD-Q	1.4362 / 1.4462*
Sleeve Stacon type SLD and SLD-Q	1.4404 / 1.4571 / 1.4362 / 1.4462*
Front plate Stacon type SLD and SLD-Q	1.4404 / 1.4571*
Stirrup of dowel Stacon type SLD and SLD-Q	B500NR from 1.4404 / 1.4571 / 1.4362 / 1.4462 / 1.4482*
Distributor Stacon type SLD-Q	B500B

*At least corrosion resistance class III according to EN 1993-1-4

Schöck Stacon type SLD and SLD-Q

Product description
Materials of type SLD and SLD-Q

Annex A3

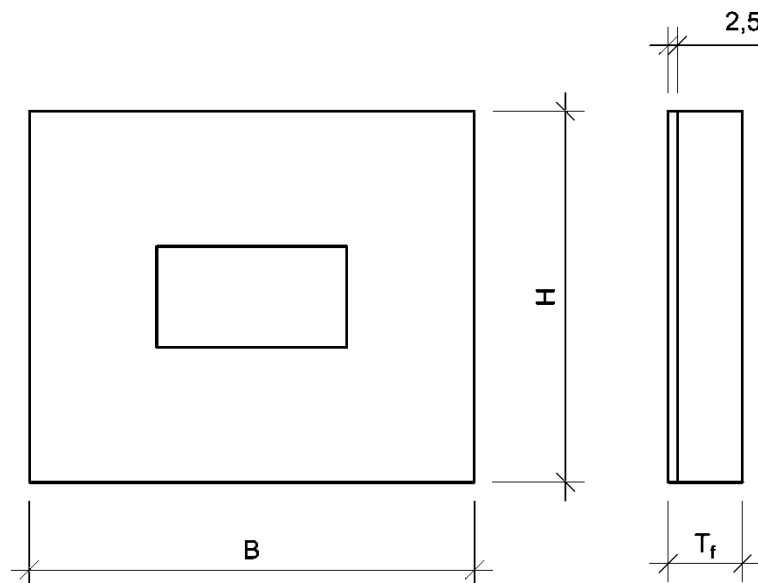

Fig. 3: Dimensions of fire protection collar SLD BSM / SLD-Q BSM

Tab. 4: Dimensions and materials of fire protection collar SLD BSM / SLD-Q BSM

Product type	Material	H [mm]	B [mm]	T _f [mm]
SLD (-Q) 200 / 220 BSM 20	Mineral wool / Promaseal PL	120	150	20
SLD (-Q) 200 / 220 BSM 30	Mineral wool / Promaseal PL	120	150	30
SLD (-Q) 250 / 270 BSM 20	Mineral wool / Promaseal PL	150	170	20
SLD (-Q) 250 / 270 BSM 30	Mineral wool / Promaseal PL	150	170	30
SLD (-Q) 300 BSM 20	Mineral wool / Promaseal PL	170	190	20
SLD (-Q) 300 BSM 30	Mineral wool / Promaseal PL	170	190	30
SLD (-Q) 350 / 400 BSM 20	Mineral wool / Promaseal PL	200	250	20
SLD (-Q) 350 / 400 BSM 30	Mineral wool / Promaseal PL	200	250	30
SLD (-Q) 450 BSM 20	Mineral wool / Promaseal PL	250	250	20
SLD (-Q) 450 BSM 30	Mineral wool / Promaseal PL	250	250	30

The fire protection collar SLD BSM or SLD-Q BSM is made of:

- 2,5 mm Promaseal® PL intumescent fire protection plate produced by PROMAT GmbH according to ETA-18/0198, with B-s1, d0 reaction to fire class according to EN 13501-1.
- 17,5 mm or 27,5 mm mineral fibre board according to EN 13162, which is classified as reaction to fire class A1 in accordance with EN 13501-1.

The declaration of performance for the mineral fibre board is part of the technical documentation deposited with Deutsches Institut für Bautechnik.

Schöck Stacon type SLD and SLD-Q	Annex A4
Product description Fire protection collars	

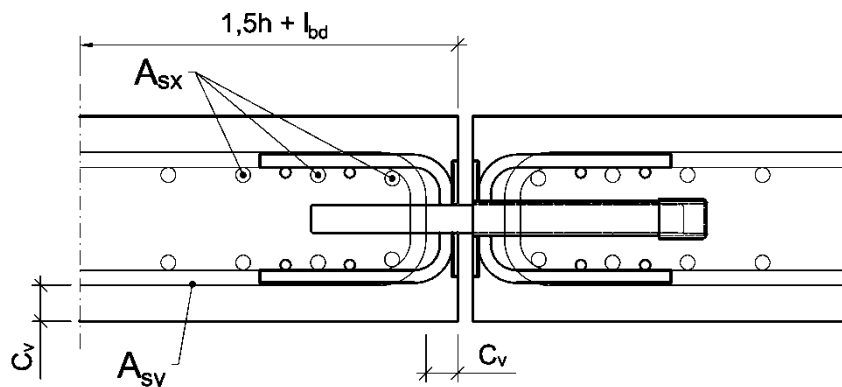

Fig. 4: Arrangement of reinforcement at minimum slab thickness

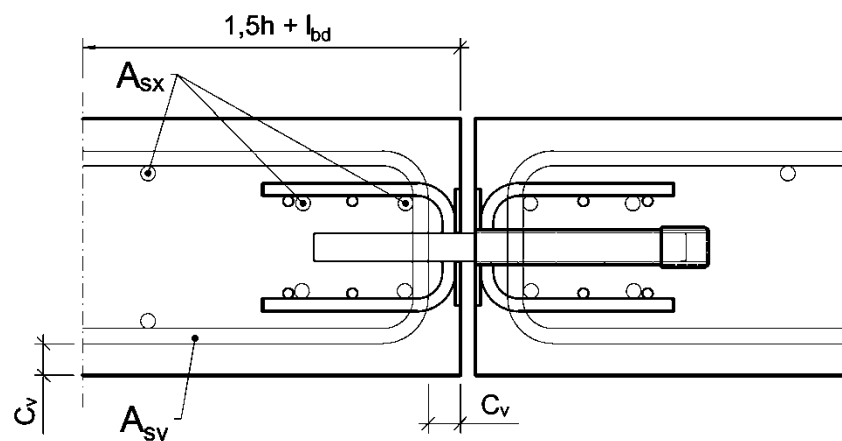

Fig. 5: Arrangement of reinforcement at average slab thickness

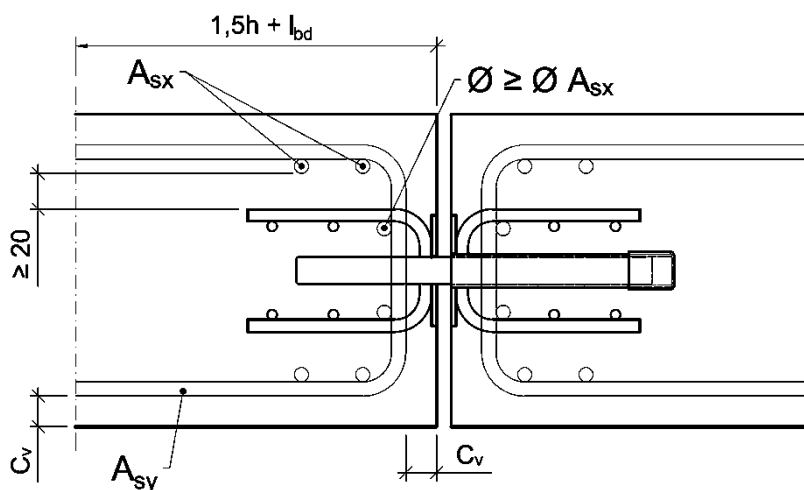

Fig. 6: Arrangement of reinforcement at maximum slab thickness

Schöck Stacon Type SLD and SLD-Q

Intended use
Arrangement of reinforcement

Annex B1

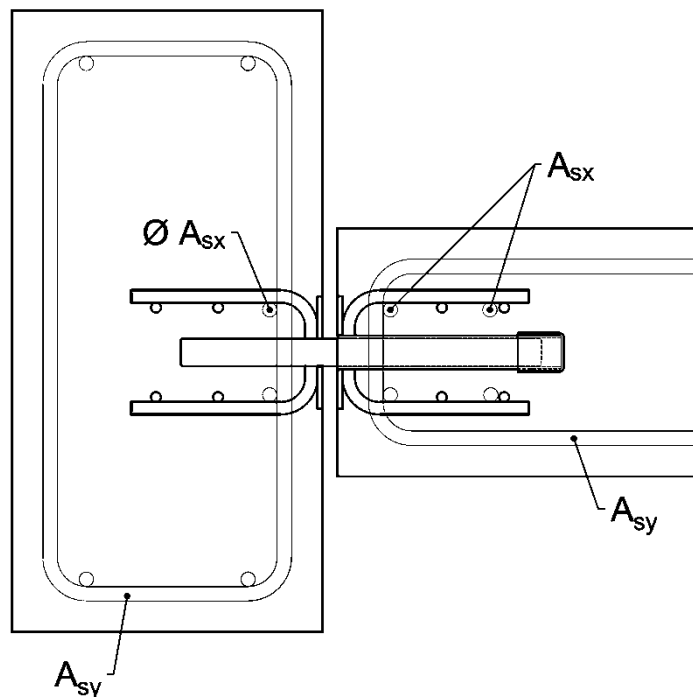

Fig. 7: Arrangement of reinforcement for beam-slab connection

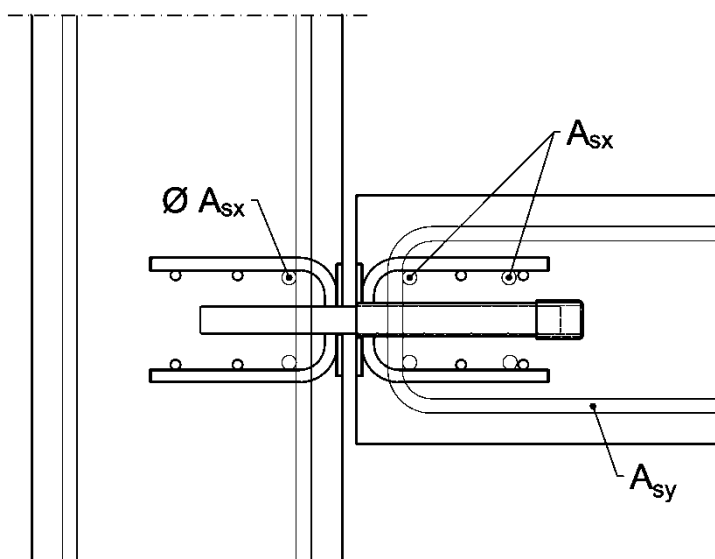

Fig. 8: Arrangement of reinforcement for wall-slab connection

- Reinforcement according to the structural design

Schöck Stacon Type SLD and SLD-Q

Intended use
Arrangement of reinforcement

Annex B2

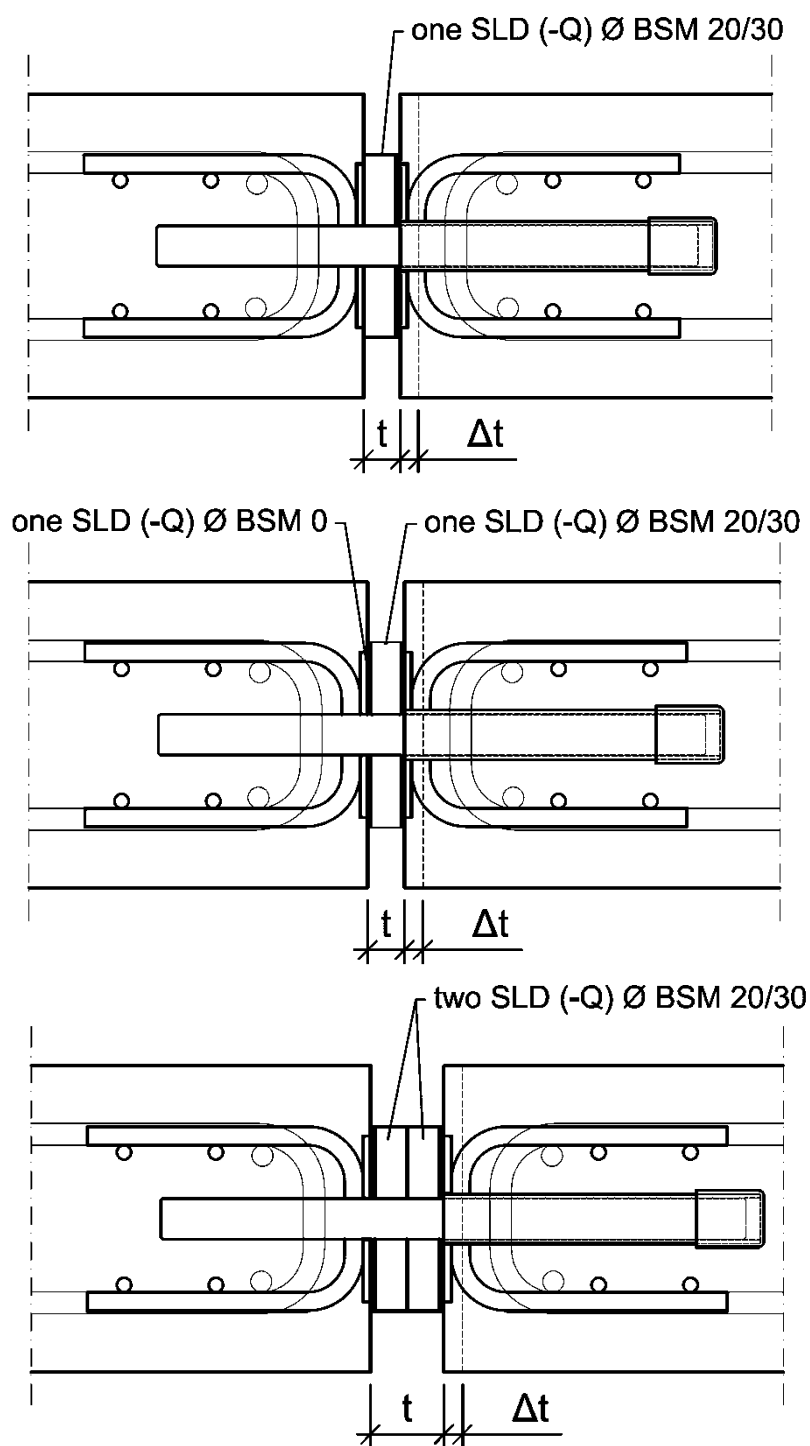

Fig. 9: Arrangement of fire protection collars for different joint widths

- An additional joint width Δt of 10 mm can be closed per BSM fire protection collar.

Schöck Stacon Type SLD and SLD-Q

Intended use
Arrangement of the SLD BSM / SLD-Q BSM fire protection collars

Annex B3

Tab. 5: Minimum slab and wall thickness for Stacon Type SLD and SLD-Q depending on the concrete cover

Stacon type	Minimum slab thickness depending on concrete cover c_v [mm]				minimum wall thickness [mm]
	$c_v = 20$ mm	$c_v = 30$ mm	$c_v = 40$ mm	$c_v = 50$ mm	
SLD 200	150	160	180	200	190
SLD 220	150	160	180	200	200
SLD 250	160	180	200	220	215
SLD 270	170	190	210	230	226
SLD 300	180	200	220	240	240
SLD 350	210	230	250	270	278
SLD 400	240	260	280	300	368
SLD 450	270	290	310	330	420
SLD-Q 200	150	160	180	200	190
SLD-Q 220	150	160	180	200	200
SLD-Q 250	160	180	200	220	215
SLD-Q 270	170	190	210	230	228
SLD-Q 300	180	200	220	240	240
SLD-Q 350	210	230	250	270	280
SLD-Q 400	240	260	280	300	370

Schöck Stacon type SLD and SLD-Q

Intended use
Application boundaries

Annex B4

Specification of intended use:

- Dowels transmit shear loads across an expansion joint between structural concrete elements made of reinforced normal weight concrete of strength class C20/25 to C50/60 according to EN 206.
- Concrete elements with a minimum slab thickness of $h = \max(6 d_{\text{bar}}; 150 \text{ mm})$. For rectangular or elongated shaped bars the greater measure in direction of the load shall be taken as d_{bar} .
- Concrete elements are subjected to static and quasi-static actions.
- Concrete elements that are subjected to fire exposure.
- Concrete elements are designed according to EN 1992-1-1 or EN 1992-1-2 and EOTA TR 065.
- Dowels with bars made of stainless steel and sleeves made of stainless steel or plastic are subjected to environmental conditions acc. to EN 1993-1-4, table A.1 dependent on the corrosion resistant class CRC III.

Schöck Stacon type SLD and SLD-Q

**Intended use
specifications**

Annex B5

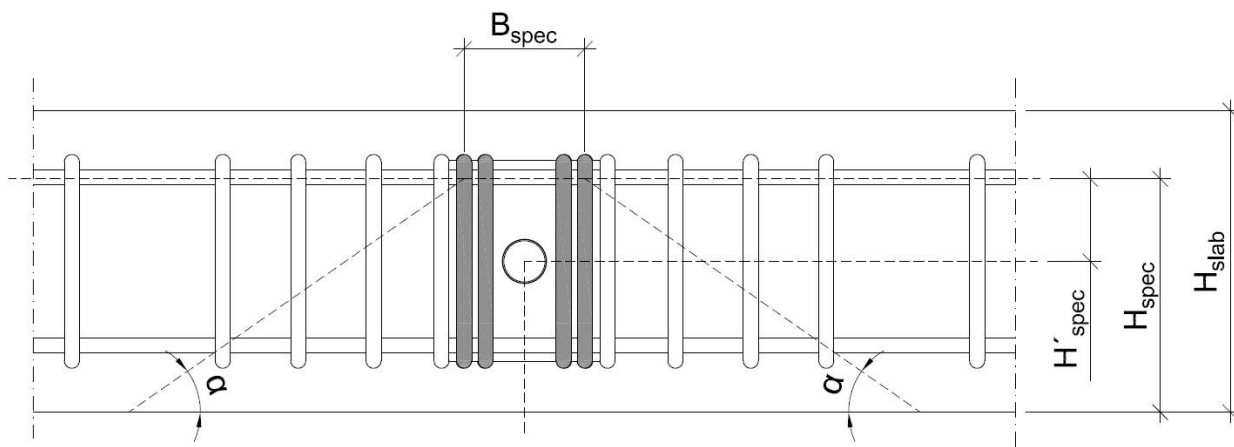

Fig. 10: Definition of the relevant parameters

Tab. 6: Resistance to concrete cone failure at ULS (Design parameters)

Stacon type	$B_{spec,1(2)}$		$H'_{spec,1(2)}$	$H_{spec,1(2)}$
	Part A4	Part S		
SLD 200	42	46	40	$H'_{spec} + 1/2 \times H_{slab}$
SLD 220	49	49	40	$H'_{spec} + 1/2 \times H_{slab}$
SLD 250	53	53	48	$H'_{spec} + 1/2 \times H_{slab}$
SLD 270	53	56	53	$H'_{spec} + 1/2 \times H_{slab}$
SLD 300	60	60	56	$H'_{spec} + 1/2 \times H_{slab}$
SLD 350	97	97	73	$H'_{spec} + 1/2 \times H_{slab}$
SLD 400	70	70	86	$H'_{spec} + 1/2 \times H_{slab}$
SLD 450	113	113	101	$H'_{spec} + 1/2 \times H_{slab}$
SLD-Q 200	42	72	40	$H'_{spec} + 1/2 \times H_{slab}$
SLD-Q 220	49	72	40	$H'_{spec} + 1/2 \times H_{slab}$
SLD-Q 250	49	116	48	$H'_{spec} + 1/2 \times H_{slab}$
SLD-Q 270	52	116	53	$H'_{spec} + 1/2 \times H_{slab}$
SLD-Q 300	60	116	58	$H'_{spec} + 1/2 \times H_{slab}$
SLD-Q 350	94	126	73	$H'_{spec} + 1/2 \times H_{slab}$
SLD-Q 400	102	132	86	$H'_{spec} + 1/2 \times H_{slab}$

The design values of the load-bearing capacities of the dowel can be determined according to EOTA TR 065.

Schöck Stacon type SLD and SLD-Q

Performance
Performance parameters

Annex C1

Resistance to fire

Performance characteristics with regard to load-bearing capacity in case of fire

If the performance characteristics specified in section 3.1 are complied with, the load-bearing capacity of the connection of reinforced concrete members with the shear force dowel in accordance with the intended use is also given under fire exposure according to the standard temperature time curve for a duration of 120 minutes if the following boundary conditions are met:

- Compliance with the design conditions according to annex B1 and the design requirements according to annex C1
- Use and installation of fire protection collars according to annexes A4 and B3
- The design of the load-bearing capacity of the connection with the shear force dowel under normal temperatures was carried out in accordance with EOTA TR 065.
- For structural fire design (accidental design situation), the action shall be determined on the basis of the normal temperature design of the load-bearing capacity, using a maximum reduction coefficient η_{fi} in accordance with EN 1992-1-2 or EN 1993-1-2, respectively, Section 2.4.2 of $\eta_{fi} = 0,7$.
- The load-bearing capacity of the reinforced concrete components under fire exposure shall be verified for the intended use.
- The concrete cover c_v is at least 30 mm and the associated minimum slab thickness according to Annex B4 is observed.

Schöck Stacon type SLD and SLD-Q	Annex C2
Performance Resistance to fire	