

Public-law institution jointly founded by the federal states and the Federation

European Technical Assessment Body  
for construction products



## European Technical Assessment

ETA-21/0470  
of 22 January 2026

English translation prepared by DIBt - Original version in German language

### General Part

Technical Assessment Body issuing the European Technical Assessment:

Deutsches Institut für Bautechnik

Trade name of the construction product

Rebar connection with  
fischer injection system FIS EB II

Product family  
to which the construction product belongs

Systems for post-installed rebar connections with mortar

Manufacturer

fischerwerke GmbH & Co. KG  
Otto-Hahn-Straße 15  
79211 Denzlingen  
DEUTSCHLAND

Manufacturing plant

fischerwerke

This European Technical Assessment contains

25 pages including 3 annexes which form an integral part of this assessment

This European Technical Assessment is issued in accordance with Article 95(4) of Regulation (EU) No 2024/3110, on the basis of

EAD 330087-01-0601

This version replaces

ETA-21/0470 issued on 3 March 2022

The European Technical Assessment is issued by the Technical Assessment Body in its official language. Translations of this European Technical Assessment in other languages shall fully correspond to the original issued document and shall be identified as such.

Communication of this European Technical Assessment, including transmission by electronic means, shall be in full. However, partial reproduction may only be made with the written consent of the issuing Technical Assessment Body. Any partial reproduction shall be identified as such.

This European Technical Assessment may be withdrawn by the issuing Technical Assessment Body, in particular pursuant to information by the Commission in accordance with Article 36(3) of Regulation (EU) No 2024/3110.

## Specific Part

### 1 Technical description of the product

The subject of this European Technical Assessment is the post-installed connection, by anchoring or overlap connection joint, of reinforcing bars (rebars) in existing structures made of normal weight concrete, using the "Rebar connection with fischer injection system FIS EB II" in accordance with the regulations for reinforced concrete construction.

Reinforcing bars made of steel with a diameter  $\phi$  from 8 to 32 mm or the fischer rebar anchor FRA or FRA HCR of sizes M12 to M24 according to Annex A and injection mortar FIS EB II are used for rebar connections. The rebar is placed into a drilled hole filled with injection mortar and is anchored via the bond between rebar, injection mortar and concrete.

The product description is given in Annex A.

### 2 Specification of the intended use in accordance with the applicable European assessment Document

The performances given in Section 3 are only valid if the rebar connection is used in compliance with the specifications and conditions given in Annex B.

The verifications and assessment methods on which this European Technical Assessment is based lead to the assumption of a working life of the rebar connections of at least 50 years. The indications given on the working life cannot be interpreted as a guarantee given by the producer, but are to be regarded only as a means for choosing the right products in relation to the expected economically reasonable working life of the works.

### 3 Performance of the product and references to the methods used for its assessment

#### 3.1 Mechanical resistance and stability (BWR 1)

Essential characteristic	Performance
Characteristic resistance under static and quasi-static loading	See Annex C1 and C2
Characteristic resistance under seismic loading	No performance assessed

#### 3.2 Safety in case of fire (BWR 2)

Essential characteristic	Performance
Reaction to fire	Class A1
Resistance to fire	See Annex C 3

### 4 Assessment and verification of constancy of performance (AVCP) system applied, with reference to its legal base

In accordance with European Assessment Document EAD No. 330087-01-0601, the applicable European legal act is: [96/582/EC].

The system to be applied is: 1

**5 Technical details necessary for the implementation of the AVCP system, as provided for in the applicable European Assessment Document**

Technical details necessary for the implementation of the AVCP system are laid down in the control plan deposited with Deutsches Institut für Bautechnik.

Issued in Berlin on 22 January 2026 by Deutsches Institut für Bautechnik

Dipl.-Ing. Beatrix Wittstock  
Head of Section

*beglaubigt:*  
Baderschneider

## Installation conditions and application examples reinforcing bars, part 1

**Figure A1.1:**

Overlap joint with existing reinforcement for rebar connections of slabs and beams

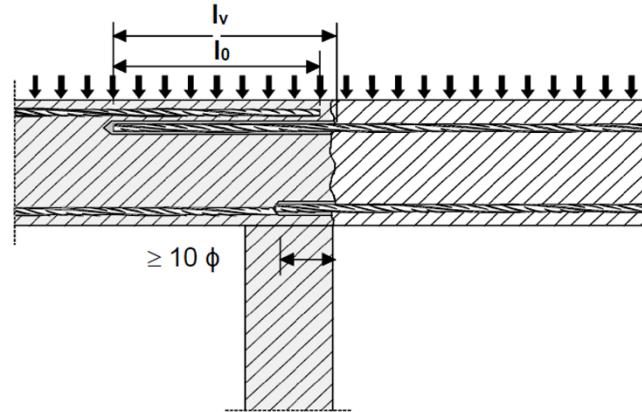

**Figure A1.2:**

Overlap joint with existing reinforcement at a foundation of a column or wall where the rebar is stressed

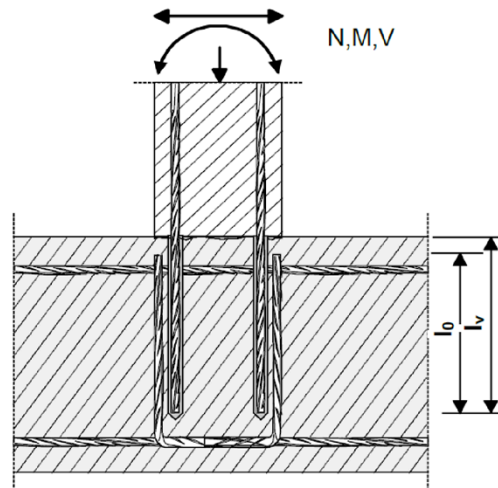

**Figure A1.3:**

End anchoring of slabs or beams (e.g. designed as simply supported)

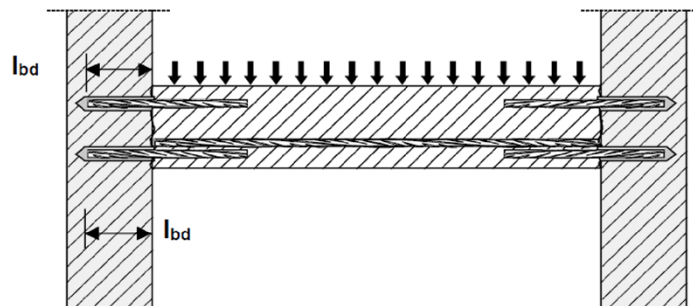

Figures not to scale

Rebar connection with fischer injection system FIS EB II

**Product description**

Installation conditions and application examples reinforcing bars, part 1

**Annex A1**

## Installation conditions and application examples reinforcing bars, part 2

**Figure A2.1:**

Rebar connection for components stressed primarily in compression

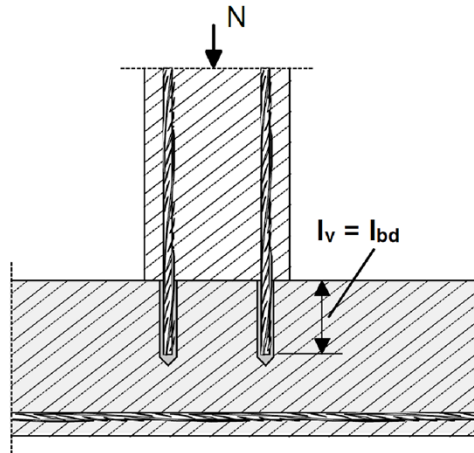

**Figure A2.2:**

Anchoring of reinforcement to cover the line of acting tensile force in the bending member

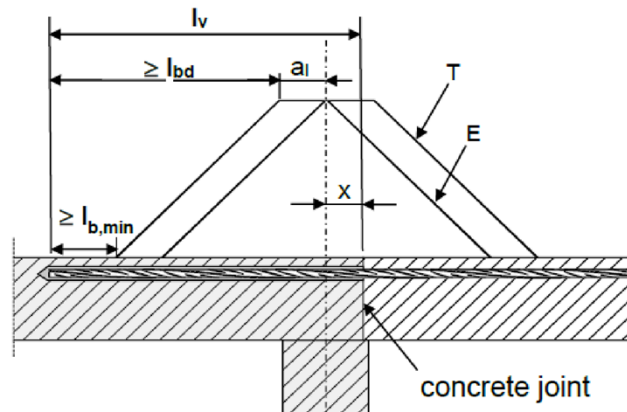

(only post-installed rebar is plotted)

Key to Figure

- T Acting tensile force
- E Envelope of  $M_{ed} / z + N_{ed}$  (see EN 1992-1-1:2011)
- x Distance between the theoretical point of support and concrete joint

Note to **figure A1.1 to A1.3** and **figure A2.1 to A2.2**

In the figures no traverse reinforcement is plotted, the transverse reinforcement as required by EN 1992-1-1:2011 shall be present.

The shear transfer between old and new concrete shall be designed according to EN 1992-1-1:2011 Preparation of joints according to **Annex B 3** of this document.

Figures not to scale

**Rebar connection with fischer injection system FIS EB II**

**Product description**

Installation conditions and application examples reinforcing bars, part 2

**Annex A2**

## Installation conditions and application examples fischer rebar anchor

**Figure A3.1:**

Lap to a foundation of a column under bending.

1. Shear lug (or fastener loaded in shear)
2. fischer rebar anchor (tension only)
3. Existing stirrup / reinforcement for overlap (lap splice)
4. Slotted hole

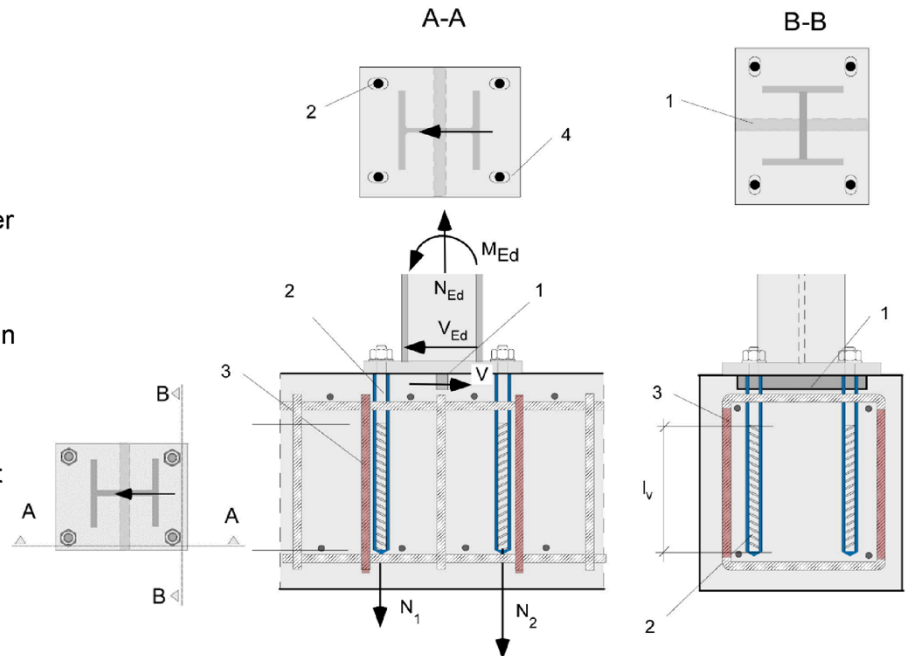
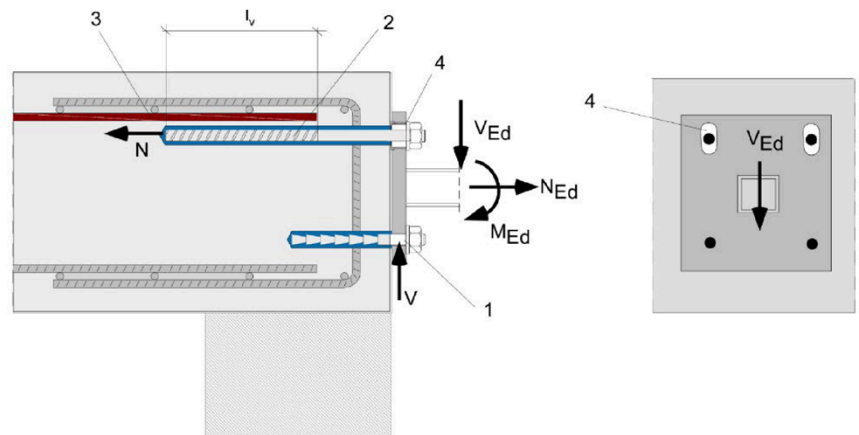

**Figure A3.2:**

Lap of the anchoring of guardrail posts or anchoring of cantilevered building components.

In the anchor plate, the drill holes for the fischer rebar anchors have to be designed as slotted holes with axial direction to the shear force.

1. Fastener for shear load transfer
2. fischer rebar anchor (tension only)
3. Existing stirrup / reinforcement for overlap (lap splice)
4. Slotted hole



The required transverse reinforcement acc. to EN 1992-1-1:2011 is not shown in the figures. **The fischer rebar anchor FRA / FRA HCR may be only used for axial tensile force.** The tensile force must be transferred by lap to the existing reinforcement of the building. The transfer of the shear force has to be ensured by suitable measures, e.g. by means of shear force or anchors with European Technical Assessment (ETA).

Figures not to scale

Rebar connection with fischer injection system FIS EB II

**Product description**

Installation conditions and application examples fischer rebar anchors FRA / FRA HCR

**Annex A3**

## Overview system components part 1

### Injection cartridge (shuttle cartridge) FIS EB II with sealing cap

Sizes: 390 ml, 585 ml, 1500 ml (the 390 ml hard cartridge is shown as an example)

Size foil bag: 500 ml

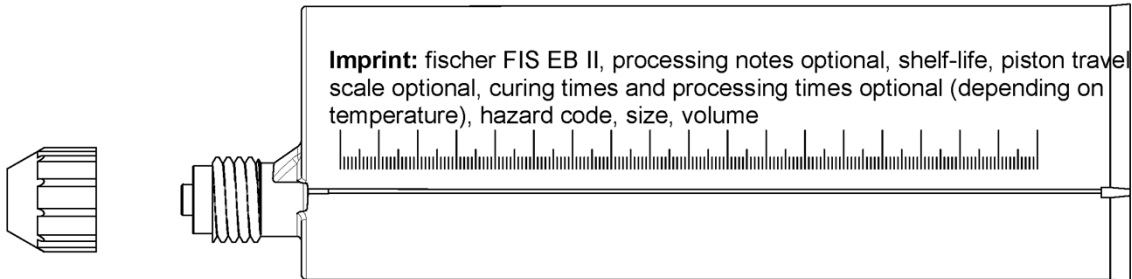

### Injection cartridge (coaxial cartridge) FIS EB II with sealing cap

Sizes: 300 ml

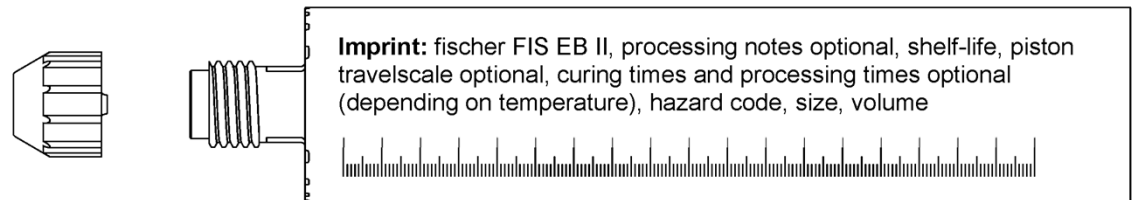

### Static mixer FIS MR Plus for injection cartridges $\leq 500$ ml

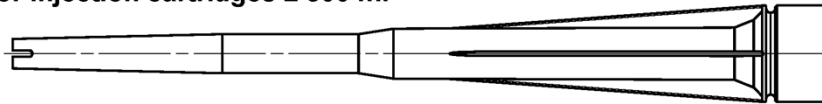

### Static mixer FIS UMR for injection cartridges $\geq 500$ ml

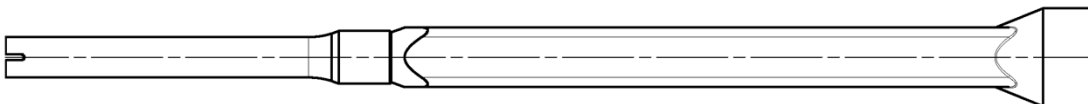

### Injection adapter and extension tube $\varnothing 9$ for static mixer FIS MR Plus; Injection adapter and extension tube $\varnothing 9$ or $\varnothing 15$ for static mixer FIS UMR

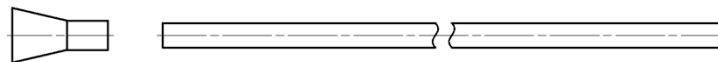

### Blow out pump AB G



### Compressed-air cleaning tool ABP with compressed-air nozzle



Figures not to scale

## Rebar connection with fischer injection system FIS EB II

### Product description

Overview system components part 1:  
injection mortar, static mixer, injection adapter, blow out pump

Annex A4

## Overview system components part 2

**Reinforcing bar (rebar);** Sizes:  $\phi 8$ ,  $\phi 10$ ,  $\phi 12$ ,  $\phi 14$ ,  $\phi 16$ ,  $\phi 20$ ,  $\phi 25$ ,  $\phi 26$ ,  $\phi 28$ ,  $\phi 30$ ,  $\phi 32$

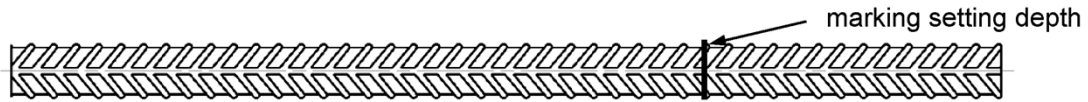

**fischer rebar anchor FRA, FRA HCR;** Sizes: M12, M16, M20, M24

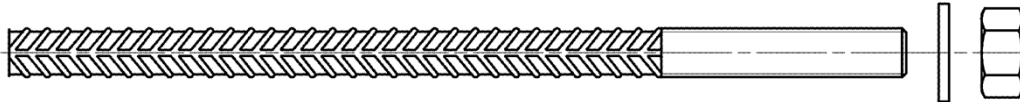

Figures not to scale

### Properties of reinforcing bars (rebar)

Figure A5.1:



- The minimum value of related rib area  $f_{R,min}$  according to EN 1992-1-1:2011
- The maximum outer rebar diameter over the ribs shall be:
  - The nominal diameter of the bar with rib  $\phi + 2 \cdot h$  ( $h \leq 0,07 \cdot \phi$ )
  - ( $\phi$ : Nominal diameter of the bar;  $h_{rib}$  = rib height of the bar)

**Table A5.1: Installation conditions for rebars**

Nominal diameter of the bar		$\phi$	8 <sup>1)</sup>	10 <sup>1)</sup>	12 <sup>1)</sup>	14	16	20	25	26	28	30	32			
Nominal drill hole diameter	$d_0$	[mm]	10	12	12	14	14	16	18	20	25	30	35	35	40	40
Drill hole depth	$h_0$		$h_0 = l_v$													
Effective embedment depth	$l_v$		acc. to static calculation													
Minimum thickness of concrete member	$h_{min}$		$l_v + 30$ ( $\geq 100$ )				$l_v + 2d_0$									

<sup>1)</sup> Both drill hole diameters can be used

**Table A5.2: Materials of rebars**

Designation	Reinforcing bar (rebar)
Reinforcing bar EN 1992-1-1:2011, Annex C	Bars and de-coiled rods class B or C with $f_{yk}$ and $k$ according to NDP or NCI of EN 1992-1-1/NA $f_{uk} = f_{tk} = k \cdot f_{yk}$

### Rebar connection with fischer injection system FIS EB II

#### Product description

Overview system components part 2: reinforcing bar, fischer rebar anchor;  
Properties and materials of reinforcing bars (rebar)

**Annex A5**

## Properties of fischer rebar anchors

Figure A6.1:

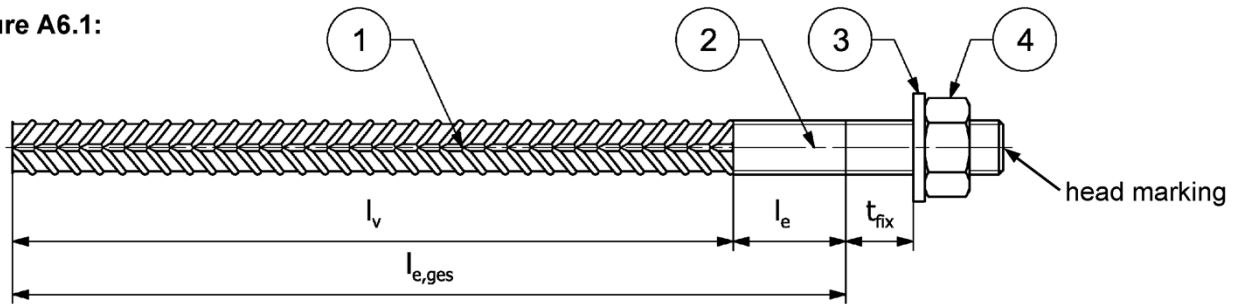

Head marking e.g.:  FRA (for stainless steel)

 FRA HCR (for high corrosion-resistant steel)

Table A6.1: Installation conditions for fischer rebar anchors

Thread diameter		M12 <sup>2)</sup>	M16	M20	M24
Nominal diameter	$\phi$ [mm]	12	16	20	25
Nominal drill bit diameter	$d_0$ [mm]	14   16	20	25	30
Drill hole depth ( $h_0 = l_{e,ges}$ )	$l_{e,ges}$ [mm]	$l_v + l_e$			
Effective embedment depth	$l_v$ [mm]	acc. to static calculation			
Distance concrete surface to welded joint	$l_e$ [mm]	100			
Diameter of clearance hole in the fixture <sup>1)</sup>	Pre-positioned $\leq d_f$ [mm]	14	18	22	26
	Push through $\leq d_f$ [mm]	16   18	22	26	32
Minimum thickness of concrete member	$h_{min}$ [mm]	$h_0 + 30$ ( $\geq 100$ )	$h_0 + 2d_0$		
Maximum torque moment for attachment of the fixture	$\max T_{inst}$ [Nm]	50	100	150	150

<sup>1)</sup> For bigger clearance holes in the fixture see EN 1992-4:2018

<sup>2)</sup> Both drill bit diameters can be used

Table A6.2: Materials of fischer rebar anchors

Part	Description	Materials	
		FRA Corrosion resistance class CRC III acc. to EN 1993-1-4:2006+A1:2015	FRA HCR Corrosion resistance class CRC V acc. to EN 1993-1-4:2006+A1:2015
1	Reinforcing bar	Bars and de-coiled rods class B or C with $f_{yk}$ and $k$ according to NDP or NCI of EN 1992-1-1:NA; $f_{uk} = f_{tk} = k \cdot f_{yk}$ ; ( $f_{yk} = 500 \text{ N/mm}^2$ )	
2	Round bar with partial or full thread	Stainless steel, strength class 80, according to EN 10088-1:2023	High corrosion-resistant steel, strength class 80, according to EN 10088-1:2023
3	Washer ISO 7089:2000	Stainless steel, according to EN 10088-1:2023	High corrosion-resistant steel, according to EN 10088-1:2023
4	Hexagon nut	Stainless steel, strength class 80, acc. to EN ISO 3506-2:2020, according to EN 10088-1:2023	High corrosion-resistant steel, strength class 80, acc. to EN ISO 3506-2:2020, according to EN 10088-1:2023



### Rebar connection with fischer injection system FIS EB II

**Product description**  
Properties and materials of fischer rebar anchors

**Annex A6**

## Specifications of intended use part 1

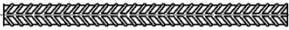
**Table B1.1:** Overview use and performance categories

Fastenings subject to		FIS EB II with ...			
		Reinforcing bar 	fischer rebar anchor 		
Hammer drilling with standard drill bit or compressed air drilling 		all sizes			
Use category	I1 dry or wet concrete	all sizes			
Characteristic resistance under static and quasi static loading,	in cracked concrete ----- in uncracked concrete	all sizes	Tables: C1.1 C1.2 C2.1	all sizes	Tables: C1.1 C1.2 C1.3 C1.4 C2.1 C2.2
Characteristic resistance under seismic loading		_1)		_1)	
Installation direction		D3 (downward and horizontal and upwards (e.g. overhead))			
Installation temperature		$T_{i,min} = +5\text{ °C}$ to $T_{i,max} = +40\text{ °C}$			
Service temperature	Temperature range	-40°C to +80°C		(max. short term temperature +80°C; max long term temperature +50°C)	
Resistance to fire		all sizes	Annex C 3	all sizes	Table C2.2
<p><sup>1)</sup> No performance assessed</p>					
Rebar connection with fischer injection system FIS EB II					Annex B1
Intended Use Specifications part 1					

## Specifications of intended use part 2

### Anchorage subject to:

- Static and quasi-static loading: reinforcing bar (rebar) size 8 mm to 32 mm
- Resistance to fire

### Base materials:

- Compacted reinforced or unreinforced normal weight concrete without fibres according to EN 206:2013+A2:2021.
- Strength classes C12/15 to C50/60 according to EN 206:2013+A2:2021.
- Maximum chloride content of 0,40 % (CL 0.40) related to the cement content according to EN 206:2013+A2:2021.
- Non-carbonated concrete

Note: In case of a carbonated surface of the existing concrete structure, the carbonated layer shall be removed in the area of the post-installed rebar connection with a diameter of  $\phi + 60$  mm prior to the installation of the new rebar. The depth of concrete to be removed shall correspond to at least the minimum concrete cover in accordance with EN1993-1-1:2011. The foregoing may be neglected if building components are new and not carbonated and if building components are in dry conditions.

### Use conditions (Environmental conditions) for fischer rebar anchors:

- For all conditions according to EN 1993-1-4:2006+A1:2015 corresponding to corrosion resistance classes to Annex A6 Table A6.2.

### Design:

- The structural design according to EN 1992-1-1:2011; EN 1992-1-2:2011 and **Annex B3 and B4** are conducted under the responsibility of a designer experienced in the field of anchorages and concrete work.
- Verifiable calculation notes and drawings are prepared taking account of the forces to be transmitted.
- The actual position of the reinforcement in the existing structure shall be determined on the basis of the construction documentation and taken into account when designing.

### Installation:

- The installation of post-installed rebar respectively fischer rebar anchor shall be done only by suitable trained installer and under supervision on site; the conditions under which an installer may be considered as suitable trained and the conditions for Supervision on site are up to the member states in which the installation is done.
- Check the position of the existing rebars (if the position of existing rebars is not known, it shall be determined using a rebar detector suitable for this purpose as well as on the basis of the construction documentation and then marked on the building component for the overlap joint).

<b>Rebar connection with fischer injection system FIS EB II</b>	<b>Annex B2</b>
<b>Intended Use</b> Specifications part 2	

## General construction rules for post-installed rebars

Figure B3.1:

- Only tension forces in the axis of the rebar may be transmitted.
- The transfer of shear forces between new concrete and existing structure shall be designed additionally according to EN 1992-1-1:2011.
- The joints for concreting must be roughened to at least such an extent that aggregate protrude.

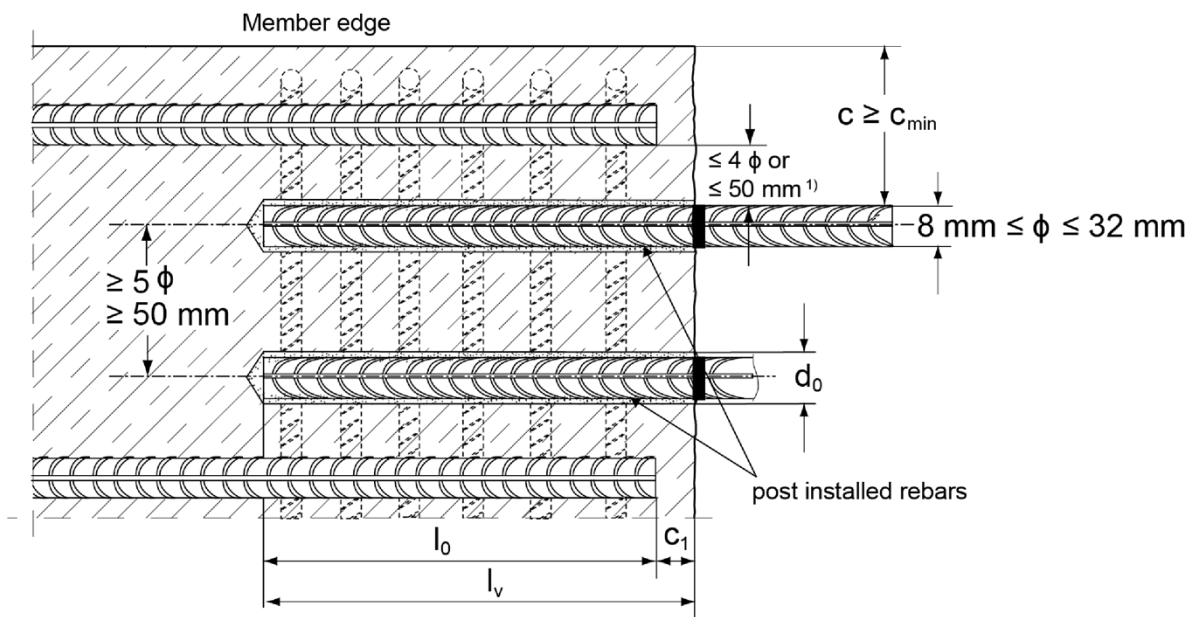

<sup>1)</sup> If the clear distance between lapped bars exceeds  $4\phi$  or 50 mm then the lap length shall be increased by the difference between the clear bar distance and the smaller  $4\phi$  or 50 mm.

- c concrete cover of post-installed rebar  
 $c_1$  concrete cover at end-face of existing rebar  
 $c_{\min}$  minimum concrete cover according to **Table B5.1** and to EN 1992-1-1:2011, Section 4.4.1.2  
 $\phi$  nominal diameter of reinforcing bar  
 $l_0$  lap length, according to EN 1992-1-1:2011  
 $l_v$  effective embedment depth,  $\geq l_0 + c_1$   
 $d_0$  nominal drill bit diameter, see **Annex B6**

Figures not to scale

Rebar connection with fischer injection system FIS EB II

Intended Use  
General construction rules for post-installed rebars

Annex B3

## General construction rules for post-installed fischer rebar anchors

Figure B4.1:

- Only tension forces in the axis of the fischer rebar anchor may be transmitted.
- The tension force must be transferred via an overlap joint to the reinforcement in the building part.
- The transmission of the shear loading shall be ensured by appropriate additional measures, e.g. by shear lugs or by anchors with a European Technical Assessment (ETA).
- In the anchor plate, the holes for the tension anchor shall be executed as slotted holes with the axis in the direction of the shear force.

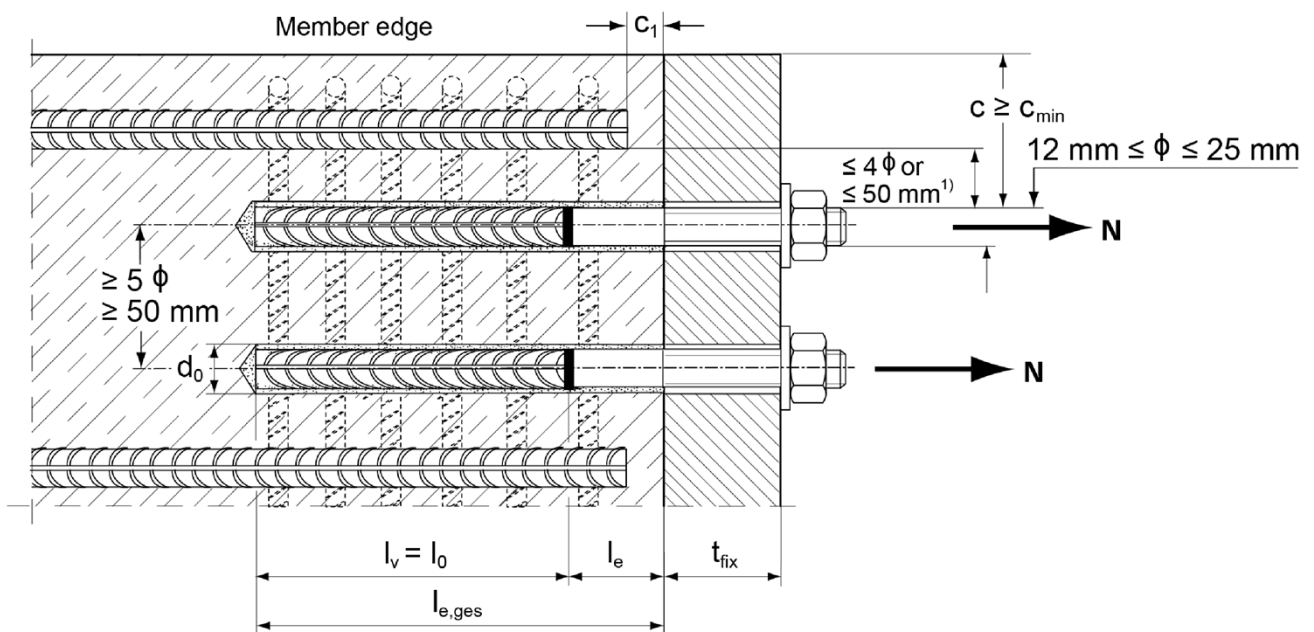

<sup>1)</sup> If the clear distance between lapped bars exceeds  $4\phi$  or  $50\text{ mm}$  then the lap length shall be increased by the difference between the clear bar distance and the smaller  $4\phi$  or  $50\text{ mm}$ .

c	concrete cover of post-installed fischer rebar anchor
$c_1$	concrete cover at end-face of existing rebar
$c_{min}$	minimum concrete cover according to <b>Table B5.1</b> and to EN 1992-1-1:2011, Section 4.4.1.2
$\phi$	nominal diameter of reinforcing bar
$l_0$	lap length, according to EN 1992-1-1:2011, Section 8.7.3
$l_{e,ges}$	overall embedment depth, $\geq l_0 + l_e$
$d_0$	nominal drill bit diameter, see <b>Annex B6</b>
$l_e$	length of the bonded in threaded part
$t_{fix}$	thickness of the fixture
$l_v$	effective embedment depth

Figures not to scale

Rebar connection with fischer injection system FIS EB II

Intended Use

General construction rules for post-installed fischer rebar anchors

Annex B4

**Table B5.1: Minimum concrete cover  $c_{min}^{(1)}$  depending on the drilling method and the drilling tolerance**

Drilling method	nominal diameter of reinforcing bar $\phi$ [mm]	Minimum concrete cover $c_{min}$	
		Without drilling aid [mm]	With drilling aid [mm]
Hammer drilling with standard drill bit	< 25	30 mm + 0,06 $l_v \geq 2 \phi$	30 mm + 0,02 $l_v \geq 2 \phi$
	$\geq 25$	40 mm + 0,06 $l_v \geq 2 \phi$	40 mm + 0,02 $l_v \geq 2 \phi$
Compressed air drilling	< 25	50 mm + 0,08 $l_v$	50 mm + 0,02 $l_v$
	$\geq 25$	60 mm + 0,08 $l_v \geq 2 \phi$	60 mm + 0,02 $l_v \geq 2 \phi$

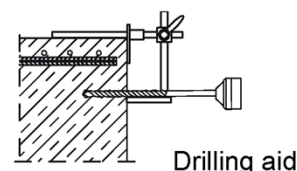

<sup>1)</sup> See Annex B 3, figure B3.1 and Annex B 4, figure B4.1

Note: The minimum concrete cover as specified in EN 1992-1-1:2011 must be observed.

**Table B5.2: Dispensers and cartridge sizes corresponding to maximum embedment depth  $l_{v,max}$  resp.  $l_{e,ges,max}$**

reinforcing bars (rebar)	fischer rebar anchor	Manual dispenser	Pneumatic or cordless dispenser (small)	Pneumatic or cordless dispenser (large)
		Cartridge size		
$\phi$ [mm]	[-]	$\geq 390$ ml (e.g. 390 ml, 500 ml, 585 ml, 1100 ml, 1500 ml)		
8 to 10	---	$l_{v,max} / l_{e,ges,max}$ [mm]		
12	FRA M12 FRA HCR M12	2000		
14	---			
16	FRA M16 FRA HCR M16			
20	FRA M20 FRA HCR M20			
25	FRA M24 FRA HCR M24			
26 to 32	---			

**Table B5.3: Conditions for use static mixer without an extension tube**

Nominal drill hole diameter $d_0$	[mm]	10	12	14	16	18	20	24	25	28	30	35	40
		Drill hole depth $h_0$ by FIS MR Plus using FIS UMR		$\leq 90$	$\leq 120$	$\leq 140$	$\leq 150$	$\leq 160$	$\leq 190$	$\leq 210$			
		-	-	$\leq 90$	$\leq 160$	$\leq 180$	$\leq 190$	$\leq 220$		$\leq 250$			

Rebar connection with fischer injection system FIS EB II

**Intended Use**  
Minimum concrete cover;  
dispenser and cartridge sizes corresponding to maximum embedment depth

**Annex B5**

**Table B6.1: Working times  $t_{work}$  and curing times  $t_{cure}$**

Temperature at anchoring base [°C] <sup>2)</sup>	Maximum processing time <sup>1)</sup> $t_{work}$	Minimum curing time $t_{cure}$
5 to 10	180 min	96 h
> 10 to 15	90 min	60 h
> 15 to 20	60 min	36 h
> 20 to 30	30 min	24 h
> 30 to 40	15 min	12 h

- <sup>1)</sup> Maximum time from the beginning of the injection to rebar / fischer rebar anchor setting and positioning  
<sup>2)</sup> If the temperature in the concrete falls below 10 °C the cartridge has to be warmed up to +20 °C.

**Table B6.2: Installation tools for drilling and cleaning the bore hole and injection of the mortar**

reinforcing bars (rebar) $\phi$ [mm]	fischer rebar anchor [-]	Drilling and cleaning				Injection	
		Nominal drill bit diameter $d_0$ [mm]	Diameter of cutting edge $d_{cut}$ [mm]	Steel brush diameter $d_b$ [mm]	Diameter of cleaning nozzle [mm]	extension tube 9 mm Injection adapter [colour]	extension tube 15 mm Injection adapter [colour]
8 <sup>1)</sup>	---	10 <sup>2)</sup>	$\leq 10,50$	11	---	---	---
10 <sup>1)</sup>	---	12	$\leq 12,50$	14	11	nature	---
		14	$\leq 14,50$	16		blue	---
12 <sup>1)</sup>	FRA M12 <sup>1)</sup> FRA HCR M12 <sup>1)</sup>	14	$\leq 14,50$	16	15	red	---
		16	$\leq 16,50$	20		yellow	---
14	---	18	$\leq 18,50$	20	19	green	green
16	FRA M16 FRA HCR M16	20	$\leq 20,55$	25		black	black
20	FRA M20 FRA HCR M20	25	$\leq 25,55$	27	28	grey	grey
25	FRA M24 <sup>1)</sup> FRA HCR M24 <sup>1)</sup>	30	$\leq 30,55$	32	28	brown	brown
26	---	35	$\leq 35,70$	37	28	brown	brown
28	---	35	$\leq 35,70$	37	28	red	red
30	---	40	$\leq 40,70$	42	38	red	red
32	---	40	$\leq 40,70$	42	38	red	red

- <sup>1)</sup> Both drill bit diameters can be used  
<sup>2)</sup> Only hammer drilling with standard drill bit

**Rebar connection with fischer injection system FIS EB II**

**Intended Use**

Working times and curing times;  
Installation tools for drilling and cleaning the bore hole and injection of the mortar

**Annex B6**

## Safety regulations



Review the Safety Data Sheet (SDS) before use for proper and safe handling!  
Wear well-fitting protective goggles and protective gloves when working with mortar FIS EB II.  
Important: Observe the instructions for use provided with each cartridge.

## Installation instruction part 1

### Hole drilling

Note: Before drilling, remove carbonated concrete; clean contact areas (see **Annex B2**)  
In case of aborted drill holes the drill hole shall be filled with mortar.

#### Hammer drilling or compressed air drilling

1

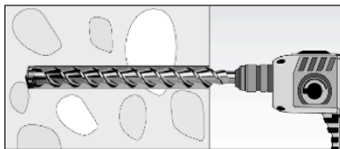

Drill the hole to the required embedment depth using a hammer drill with carbide drill bit set in rotation hammer mode or a pneumatic drill.  
Drill bit sizes see **Table B6.2**.

2

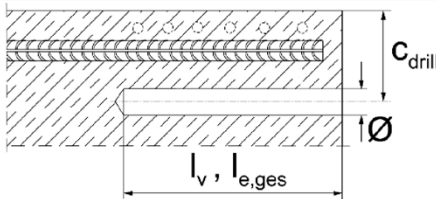

Measure and control concrete cover  $c$   
( $c_{\text{drill}} = c + \text{Ø} / 2$ )  
Drill parallel to surface edge and to existing rebar.  
Where applicable use fischer drilling aid.

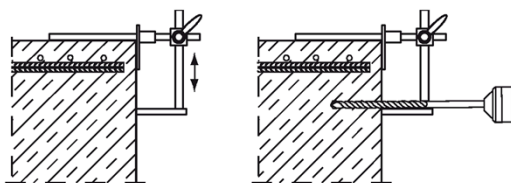

For holes  $l_v > 20$  cm use drilling aid.  
Three different options can be considered:  
A) fischer drilling aid  
B) Slat or spirit level  
C) Visual check

Minimum concrete cover  $c_{\text{min}}$  see **Table B5.1**

## Rebar connection with fischer injection system FIS EB II

### Intended Use

Safety regulations; Installation instruction part 1, hole drilling

**Annex B7**

## Installation instruction part 2

### Drill hole cleaning with oil-free compressed air

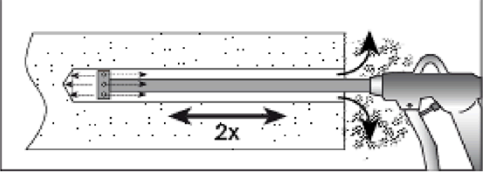
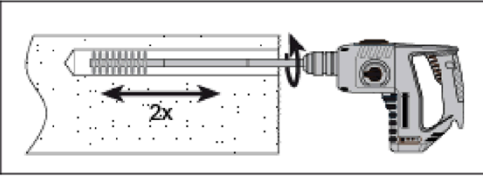
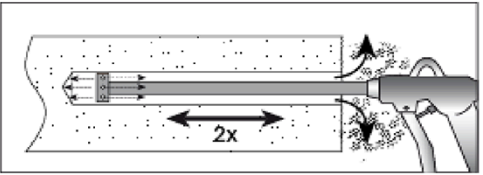
<b>3a</b>		<p><b>Blowing</b> twice from the back of the hole with the appropriate nozzle (oil-free compressed air <math>\geq 6</math> bar) until return air stream is free of noticeable dust. Personal protective equipment must be used (see safety regulations <b>Annex B7</b>).</p>
		<p><b>Brushing (with power drill)</b> Check steel brush with brush control template. The brush must produce a noticeable resistance when it is inserted into the drill hole. Fix an adequate steel brush with an extension into a drilling machine and brush the bore hole twice.</p>
		<p><b>Blowing</b> twice from the back of the hole with the appropriate nozzle (oil-free compressed air <math>\geq 6</math> bar) until return air stream is free of noticeable dust. Personal protective equipment must be used (see safety regulations <b>Annex B7</b>).</p>

Go to step 4

Rebar connection with fischer injection system FIS EB II

**Intended Use**

Installation instruction part 2, drill hole cleaning

**Annex B8**

### Installation instruction part 3

Drill hole cleaning: manual cleaning is permitted for hammer drilled boreholes up to hole diameters  $d_0 < 18 \text{ mm}$  and depths  $l_v$  resp.  $l_{e,ges} \leq 12 \cdot \phi$

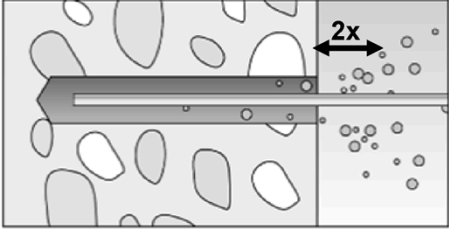
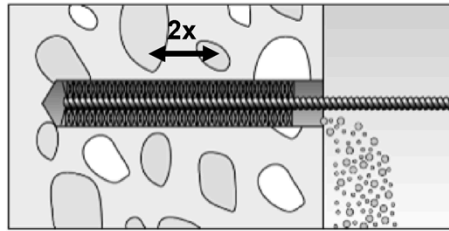
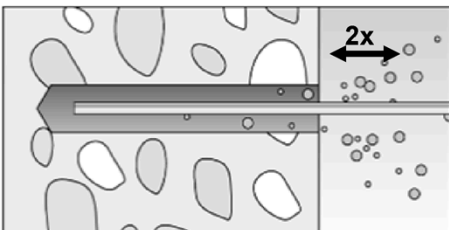
<b>3b</b>		<p><b>Blowing</b> blow out the hole twice by hand from the back of the hole. Use only the fischer blow out pump AB G. Personal protective equipment must be used (see safety regulations <b>Annex B7</b>).</p>
		<p><b>Brushing</b> Twice with the specified brush size by inserting the round steel brush to the back of the hole and twisting motion. The brush must produce a noticeable resistance when it is inserted into the drill hole. Corresponding brushes see <b>Table B6.2</b>.</p>
		<p><b>Blowing</b> blow out the hole twice by hand from the back of the hole. Use only the fischer blow out pump AB G. Personal protective equipment must be used (see safety regulations <b>Annex B7</b>).</p>

Go to step 4

Rebar connection with fischer injection system FIS EB II

Annex B9

**Intended Use**  
Installation instruction part 3, drill hole cleaning

## Installation instruction part 4

### reinforcing bars (rebar) / fischer rebar anchor and cartridge preparation

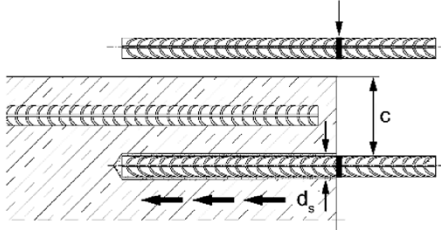
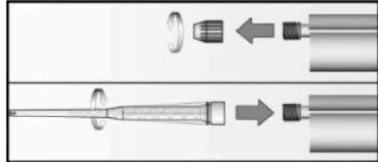
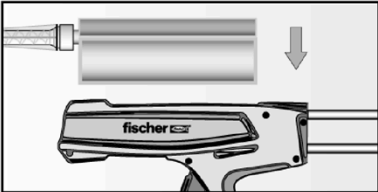
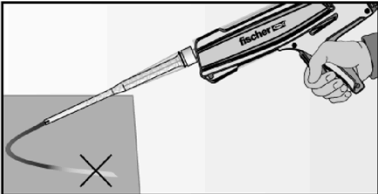
4		<p>Before use, make asure that the rebar or the fischer rebar anchor is dry and free of oil or other residue. Mark the embedment depth <math>l_v</math> resp. <math>l_{e,ges}</math> (e.g. with tape) Insert rebar in borehole, to verify drill hole depth and setting depth <math>l_v</math> resp. <math>l_{e,ges}</math></p>
5		<p>Twist off the sealing cap Twist on the static mixer (the spiral in the static mixer must be clearly visible).</p>
6		<p>Place the cartridge into a suitable dispenser.  When using the foilbag, the foil container holder must be used.</p>
7		<p>Press out approximately 10 cm of mortar until the resin is permanently grey in colour. Mortar which is not grey in colour will not cure and must be disposed.</p>

Go to step 8

Rebar connection with fischer injection system FIS EB II

**Intended Use**

Installation instruction part 4,  
reinforcing bars (rebar) / fischer rebar anchor and cartridge preparation

**Annex B10**

## Installation instruction part 5; Installation with FIS EB II

### Injection of the mortar without extension tube

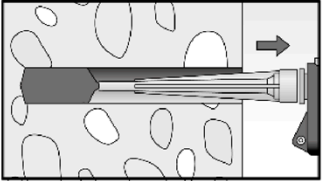
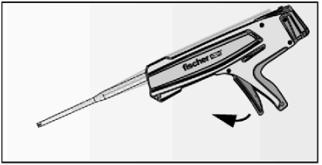
8a		<p>Inject the mortar from the back of the hole towards the front and slowly withdraw the static mixer step by step with each trigger pull. Avoid bubbles. Fill holes approximately 2/3 full, to ensure that the annular gap between the rebar and the concrete will be completely filled with adhesive over the entire embedment length. The conditions for mortar injection without extension tube can be found in <b>Table B5.3</b></p>
		<p>After injecting, release the dispenser. This will prevent further mortar discharge from the static mixer.</p>

### Injection of the mortar with extension tube

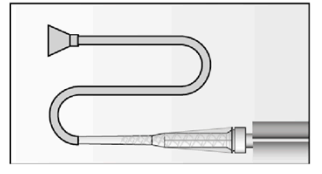
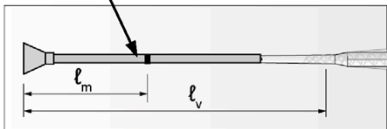
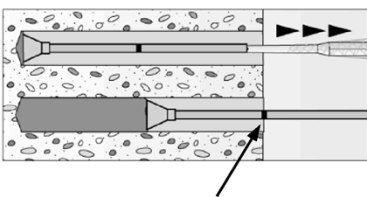
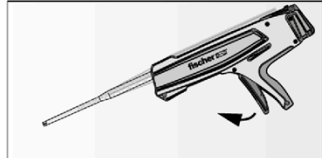
		<p>Assemble mixing nozzle FIS MR Plus or FIS UMR, extension tube and appropriate injection adapter (see <b>Table B6.2</b>)</p>
8b	<p>Mortar level mark</p> 	<p>Mark the required mortar level <math>l_m</math> and embedment depth <math>l_v</math> resp. <math>l_{e,ges}</math> with tape or marker on the injection extension tube. a) Estimation: <math display="block">l_m = \frac{1}{3} \cdot l_v \text{ resp. } l_m = \frac{1}{3} \cdot l_{e,ges} \text{ [mm]}</math> b) Precise equation for optimum mortar volume: <math display="block">l_m = l_v \text{ resp. } l_{e,ges} \left( (1,2 \cdot \frac{d_s^2}{d_0^2} - 0,2) \right) \text{ [mm]}</math></p>
	 <p>Mortar level mark</p>	<p>Insert injection adapter to back of the hole. Begin injection allowing the pressure of the injected adhesive mortar to push the injection adapter towards the front of the hole. Do not actively pull out! Fill holes approximately 2/3 full, to ensure that the annular gap between the rebar and the concrete will be completely filled with adhesive over the embedment length. When using an injection adapter continue injection until the mortar level mark <math>l_m</math> becomes visible. Maximum embedment depth, see <b>Table B5.2</b></p>
		<p>After injecting, release the dispenser. This will prevent further mortar discharge from the static mixer.</p>

Go to step 9



## Rebar connection with fischer injection system FIS EB II

**Intended Use**  
Installation instruction part 5, mortar injection

**Annex B11**

## Installation instruction part 6; Inatallation with FIS EB II

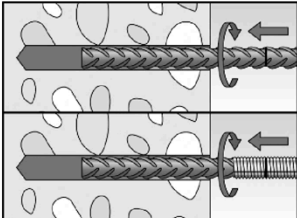
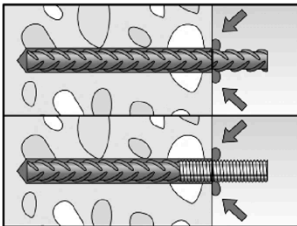
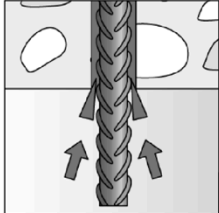
### Insert rebar / fischer rebar anchor

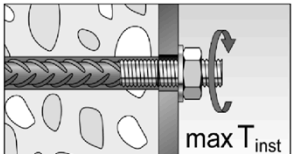
9		<p>Insert the rebar / fischer rebar anchor FRA / FRA HCR slowly twisted into the borehole until the embedment mark is reached. Recommendation: Rotation back and forth of the reinforcement bar or the fischer rebar anchor FRA makes pushing easy.</p>
10		<p>After installing the rebar or fischer rebar anchor FRA / FRA HCR the annular gap must be completely filled with mortar. Proper installation</p> <ul style="list-style-type: none"> <li>• Desired embedment depth is reached <math>l_v</math> resp. <math>l_{e,ges}</math>: embedment mark at concrete surface</li> <li>• Excess mortar flows out of the borehole after the rebar or fischer rebar anchor have been fully inserted up to the embedment mark.</li> </ul>
11		<p>For overhead installation, support the rebar / fischer rebar anchor FRA / FRA HCR and secure it from falling till mortar started to harden, e.g. using wedges.</p>
12		<p>Observe the working time "<math>t_{work}</math>" (see <b>table B6.1</b>), which varies according to temperature of base material. Minor adjustments to the rebar / fischer rebar anchor position may be performed during the working time. Full load may be applied only after the curing time "<math>t_{cure}</math>" has elapsed (see <b>Table B6.1</b>)</p>
13		<p>Mounting the fixture, <math>\max T_{inst}</math> see <b>Table A6.1</b></p>

## Rebar connection with fischer injection system FIS EB II

**Intended Use**  
Installation instruction part 6, insert rebar / fischer rebar anchor

**Annex B12**

### Minimum anchorage length and minimum lap length

The minimum anchorage length  $l_{b,min}$  and the minimum lap length  $l_{o,min}$  according to EN 1992-1-1:2011 shall be multiplied by the relevant amplification factor  $\alpha_{lb}$  according to **Table C1.1**.

**Table C1.1:** Amplification factor  $\alpha_{lb}$  related to concrete strength class and drilling method

Hammer drilling and compressed air drilling									
Rebar / fischer rebar anchor $\phi$ [mm]	Amplification factor $\alpha_{lb}$								
	Concrete strength class								
	C12/15	C16/20	C20/25	C25/30	C30/37	C35/45	C40/50	C45/55	C50/60
8 to 32	1,0								

**Table C1.2:** Bond efficiency factor  $k_b$  for hammer drilling and compressed air drilling

Hammer drilling and compressed air drilling									
Rebar / fischer rebar anchor $\phi$ [mm]	Bond efficiency factor $k_b$								
	Concrete strength class								
	C12/15	C16/20	C20/25	C25/30	C30/37	C35/45	C40/50	C45/55	C50/60
8 to 32	1,0								

**Table C1.3:** Characteristic tensile yield strength for rebar part of fischer rebar anchors

fischer rebar anchor FRA / FRA HCR		M12	M16	M20	M24
Characteristic tensile yield strength for rebar part					
Rebar diameter	$\phi$ [mm]	12	16	20	25
Characteristic tensile yield strength	$f_{yk}$ [N/mm <sup>2</sup> ]	500	500	500	500
Partial factor for rebar part	$\gamma_{Ms,N}^{1)}$ [-]	1,15			

<sup>1)</sup> In absence of national regulations

**Table C1.4:** Characteristic resistance to steel failure under tension loading of fischer rebar anchors

fischer rebar anchor FRA / FRA HCR		M12	M16	M20	M24
Characteristic resistance to steel failure under tension loading					
Characteristic resistance	$N_{Rk,s}$ [kN]	62,0	111,0	173,0	236,5
Partial factor					
Partial factor	$\gamma_{Ms,N}^{1)}$ [-]	1,4			

<sup>1)</sup> In absence of national regulations

### Rebar connection with fischer injection system FIS EB II

**Performances**  
Amplification factor  $\alpha_{lb}$ , bond efficiency factor  $k_b$ , characteristic resistance to steel failure of fischer rebar anchors; characteristic tensile yield strength for rebar part

**Annex C1**

**Table C2.1:** Design values of the bond strength  $f_{bd,PIR}$  in N/mm<sup>2</sup> for hammer drilling, compressed air drilling

$$f_{bd,PIR} = k_b \cdot f_{bd}$$

$f_{bd}$ : Design value of the bond strength in N/mm<sup>2</sup> considering the concrete strength classes and the rebar diameter for good bond condition (for all other bond conditions multiply the values by  $\eta_1 = 0,7$ ) and recommended partial factor  $\gamma_c = 1,5$  according to EN 1992-1-1:2011

$k_b$ : Bond efficiency factor according to **Table C1.2**

**Hammer drilling and compressed air drilling**

Rebar / fischer rebar anchor	bond strength $f_{bd,PIR}$ [N/mm <sup>2</sup> ]								
	Concrete strength class								
	C12/15	C16/20	C20/25	C25/30	C30/37	C35/45	C40/50	C45/55	C50/60
$\phi$ [mm]									
8 to 32	1,7	2,0	2,3	2,7	3,0	3,4	3,7	4,0	4,3

**Table C2.2:** Characteristics resistance to **steel failure** for **fischer rebar anchors** under tension loading and fire exposure R30 to R120

For concrete strength classes C12/C15 to C50/60 acc. to EN 1992-4:2018

fischer rebar anchor FRA / FRA HCR				M12	M16	M20	M24
Characteristic resistance to steel failure under tension loading and fire exposure	R30	$N_{Rk,s,fi}$	[kN]	2,5	4,7	7,4	10,6
	R60			2,1	3,9	6,1	8,8
	R90			1,7	3,1	4,9	7,1
	R120			1,3	2,5	3,9	5,6

**Rebar connection with fischer injection system FIS EB II**

**Performances**

Design values of the bond strength  $f_{bd,PIR}$ ; characteristic resistance to steel failure for fischer rebar anchor  $N_{Rk,s,fi}$  under tension loading and fire exposure

**Annex C2**

### The bond strength $f_{bd,fi}$ at increased temperature for concrete strength classes C12/15 to C50/60 (all drilling methods)

The bond strength  $f_{bd,fi}$  at increased temperature has to be calculated by the following equation:

$$f_{bd,fi} = k_{fi}(\theta) \cdot f_{bd,PIR} \cdot \frac{\gamma_c}{\gamma_{m,fi}}$$

If:  $\theta > 49 \text{ }^\circ\text{C}$        $k_{fi}(\theta) = \frac{39924 \cdot \theta^{-2,134}}{f_{bd,PIR} \cdot 4,3} \leq 1,0$

If:  $\theta > \theta_{max} (200 \text{ }^\circ\text{C})$        $k_{fi}(\theta) = 0$

- $f_{bd,fi}$  = The bond strength at increased temperature in N/mm<sup>2</sup>
- $(\theta)$  = Temperature in °C in the mortar layer
- $k_{fi}(\theta)$  = Reduction factor at increased temperature
- $f_{bd,PIR}$  = Design value of the bond strength in N/mm<sup>2</sup> in cold condition according to **Table C2.1** considering the concrete classes, the rebar diameter, the drilling method and the bond conditions according to EN 1992-1-1:2011
- $\gamma_c$  = 1,5 recommended partial factor according to EN 1992-1-1:2011
- $\gamma_{m,fi}$  = 1,0 recommended partial factor

For evidence at increased temperature the anchorage length shall be calculated according to EN 1992-1-1:2011 Equation 8.3 using the temperature-dependent ultimate bond strength  $f_{bd,fi}$ .

**Figure C3.1:** Example of the graph of reduction factor  $k_{fi}(\theta)$  for concrete strength class C20/25 for good bond conditions

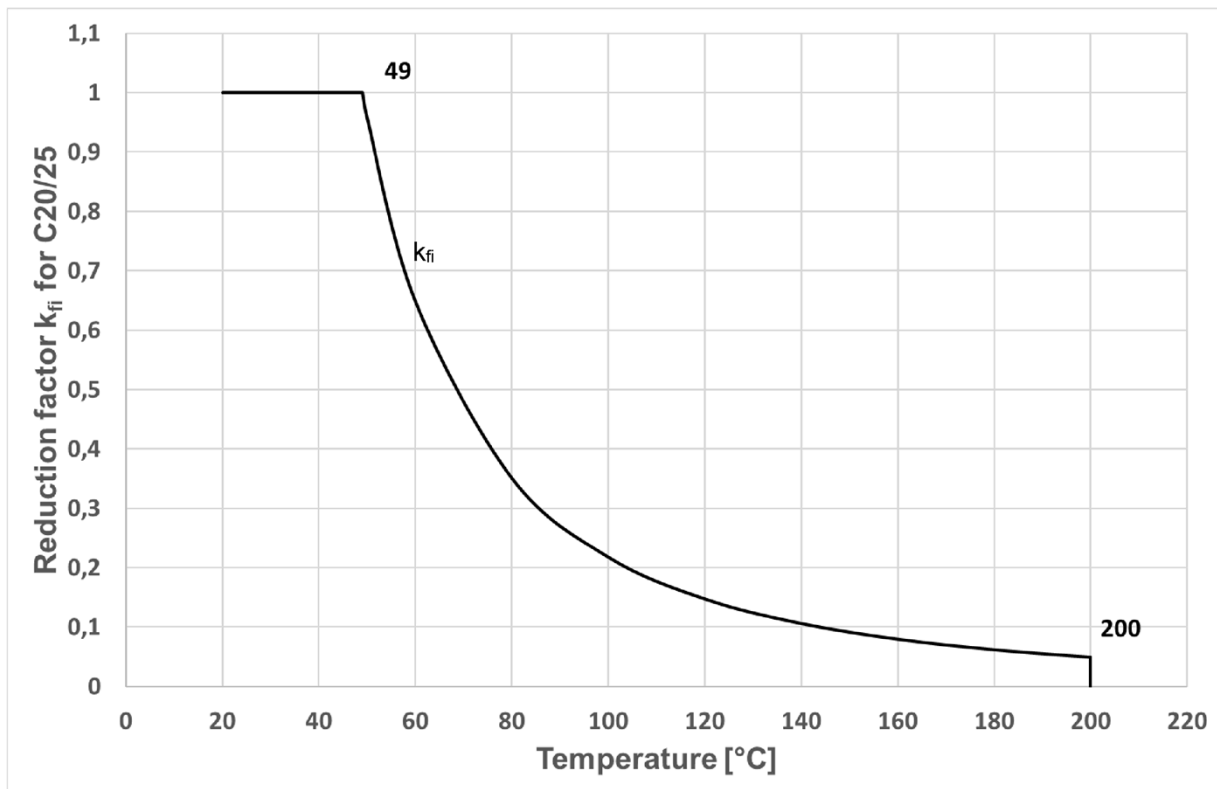

Rebar connection with fischer injection system FIS EB II

**Performances**  
Design values of bond strength  $f_{bd,fi}$  at increased temperature

**Annex C3**