

Public-law institution jointly founded by the federal states and the Federation

European Technical Assessment Body
for construction products



European Technical Assessment

ETA-22/0611
of 30 March 2026

English translation prepared by DIBt - Original version in German language

General Part

Technical Assessment Body issuing the European Technical Assessment:

Deutsches Institut für Bautechnik

Trade name of the construction product

ThermoDrive-V2

Product family to which the construction product belongs

Plastic anchor for fixing of external thermal insulation composite systems with rendering

Manufacturer

Wkret-met Sp. Z o.o.
Kuznica Kiedrzynska
ul. Wincentego Witosa 170/176
42-233 MYKANÓW
POLAND

Manufacturing plant

Plant 1, Plant 2 Poland

This European Technical Assessment contains

19 pages including 3 annexes which form an integral part of this assessment

This European Technical Assessment is issued in accordance with Article 95(4) of Regulation (EU) No 2024/3110, on the basis of

EAD 330196-01-0604

This version replaces

ETA-22/0611 issued on 12 February 2025

The European Technical Assessment is issued by the Technical Assessment Body in its official language. Translations of this European Technical Assessment in other languages shall fully correspond to the original issued document and shall be identified as such.

Communication of this European Technical Assessment, including transmission by electronic means, shall be in full. However, partial reproduction may only be made with the written consent of the issuing Technical Assessment Body. Any partial reproduction shall be identified as such.

This European Technical Assessment may be withdrawn by the issuing Technical Assessment Body, in particular pursuant to information by the Commission in accordance with Article 36(3) of Regulation (EU) No 2024/3110.

Specific Part

1 Technical description of the product

The screwed-in anchor ThermoDrive-V2 with plate consists of an anchor sleeve made of polyethylene (virgin material) and an accompanying specific screw made of galvanized steel or of steel with zinc flake coating or of stainless steel.

The product description is given in Annex A.

2 Specification of the intended use in accordance with the applicable European Assessment Document

The performances given in Section 3 are only valid if the anchor is used in compliance with the specifications and conditions given in Annex B.

The verifications and assessment methods on which this European Technical Assessment is based lead to the assumption of a working life of the anchor of at least 25 years. The indications given on the working life cannot be interpreted as a guarantee given by the producer, but are to be regarded only as a means for choosing the right products in relation to the expected economically reasonable working life of the works.

3 Performance of the product and references to the methods used for its assessment

3.1 Safety and accessibility in use (BWR 4)

Essential characteristic	Performance
Characteristic load bearing capacity <ul style="list-style-type: none">- Characteristic resistance under tension load- Minimum edge distance and spacing	See Annex C 1, C 2 and C 3 See Annex B 2
Displacements	See Annex C 4
Plate stiffness	See Annex C 4

3.2 Energy economy and heat retention (BWR 6)

Essential characteristic	Performance
Point thermal transmittance	See Annex C 4

4 Assessment and verification of constancy of performance (AVCP) system applied, with reference to its legal base

In accordance with EAD No. 330196-01-0604, the applicable European legal act is: [97/463/EC].

The system to be applied is: 2+

5 Technical details necessary for the implementation of the AVCP system, as provided for in the applicable European Assessment Document

Technical details necessary for the implementation of the AVCP system are laid down in the control plan deposited with Deutsches Institut für Bautechnik.

Issued in Berlin on 30 March 2026 by Deutsches Institut für Bautechnik

Dipl.-Ing. Beatrix Wittstock
Head of Section

beglaubigt:
Ziegler

ThermoDrive-V2

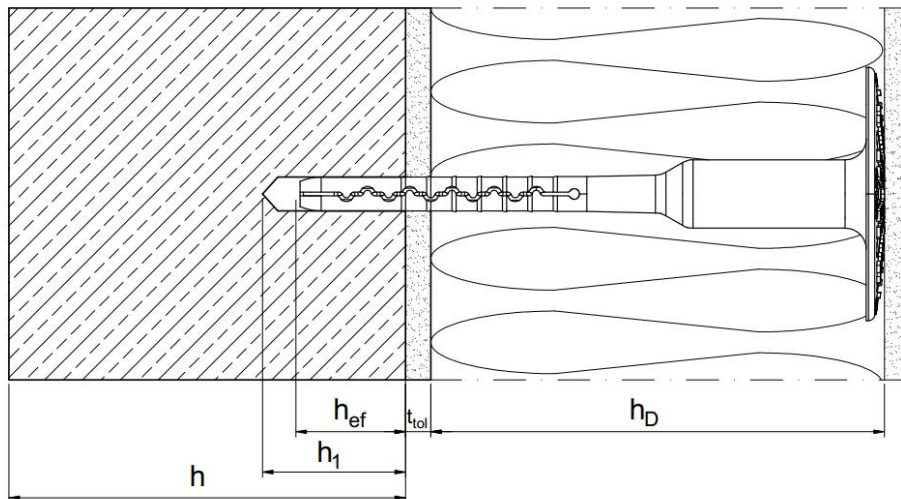

surface mount

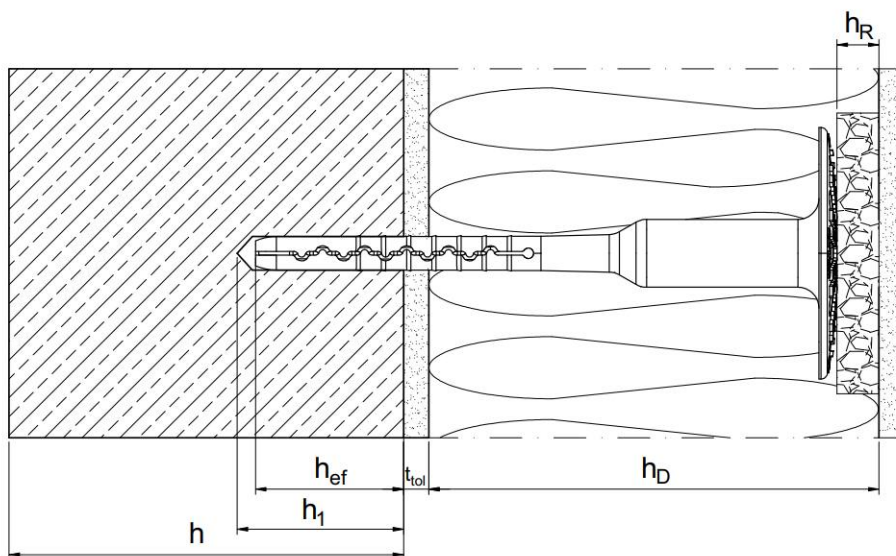

immersed mount

- Legend:
- h_D = thickness of insulation material
 - h_{ef} = effective anchorage depth
 - h = thickness of member (wall)
 - h_1 = depth of drilled hole to deepest point
 - t_{tol} = thickness of equalizing layer or non-load-bearing coating
 - h_R = thickness of insulation cover

ThermoDrive-V2

Product description

Installed condition – surface mount, immersed mount

Annex A 1

ThermoDrive-V2

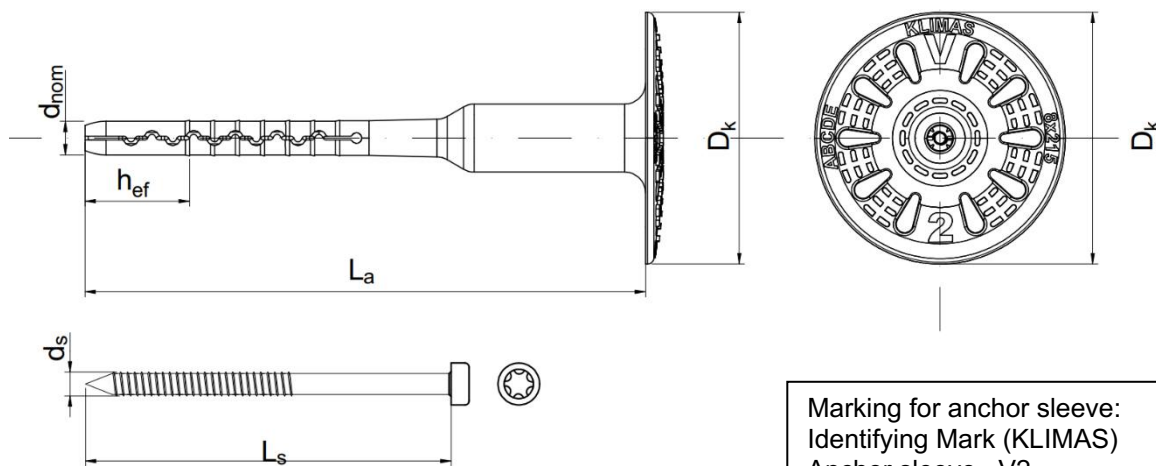

Marking for anchor sleeve:
Identifying Mark (KLIMAS)
Anchor sleeve –V2
Anchor size – 8xL_k
Base material group (ABCDE)

Accompanying specific screw

Table A1: Dimensions

Anchor Type	Anchor sleeve					Specific screw		
	D _k [mm]	d _{nom} [mm]	min L _a [mm]	max L _a [mm]	min h _{ef} [mm]	d _s [mm]	min L _s [mm]	max L _s [mm]
ThermoDrive-V2	60	8	135	475	25/45*	5,8	75	295

* effective anchorage depth for base material group E

Determination of maximum thickness of insulation h_D [mm] for ThermoDrive-V2:

$$h_D = L_a - t_{tol} - h_{ef} \quad (\text{e.g. } L_a = 195; t_{tol} = 10)$$

e.g. $h_D = 195 - 10 - 25 = 160$

ThermoDrive-V2

Product description

ThermoDrive-V2 - marking and dimension of the anchor sleeve and specific screw

Annex A 2

Table A2: Materials

Name	Materials
Anchor sleeve	Polyethylene (natural, grey, blue or black) – virgin material
Screw	Steel, electro galvanized $\geq 5 \mu\text{m}$ in accordance with EN ISO 4042:2022 or non-electrolytically applied zinc flake coatings $\geq 5 \mu\text{m}$ in accordance with EN ISO 10683:2018 or stainless steel grade 1.4301, 1.4306, 1.4307, 1.4567 (AISI 304) or 1.4401, 1.4404, 1.4571, 1.4362, 1.4578 (AISI 316), in accordance with EN 10088-3:2014
Insulation cover	KS, KSV: Polystyrene (EPS), colour: white KSG, KSVG: Polystyrene (EPS), colour: grey EDMW: mineral wool (MW), colour: natural

Table A3: Additional slip on plates - diameters and material

Plate type	Outer diameter [mm]	Material
TDX-P-90	90	Polyethylene (natural, grey, blue or black)
TDX-90	90	Polyamide +GF (natural or grey)
TDX-P-140	140	Polyethylene (natural, grey, blue or black)
TDX-140	140	Polyamide +GF (natural or grey)
TDMW-110	110	Polyamide +GF (natural or grey)
TDMW-P-110	110	Polyethylene (natural, grey, blue or black)
TDPS-60	63	Polyamide +GF (natural or grey)
TDPS-P-60	63	Polyethylene (natural, grey, blue or black)

ThermoDrive-V2

Product description
Materials

Annex A 3

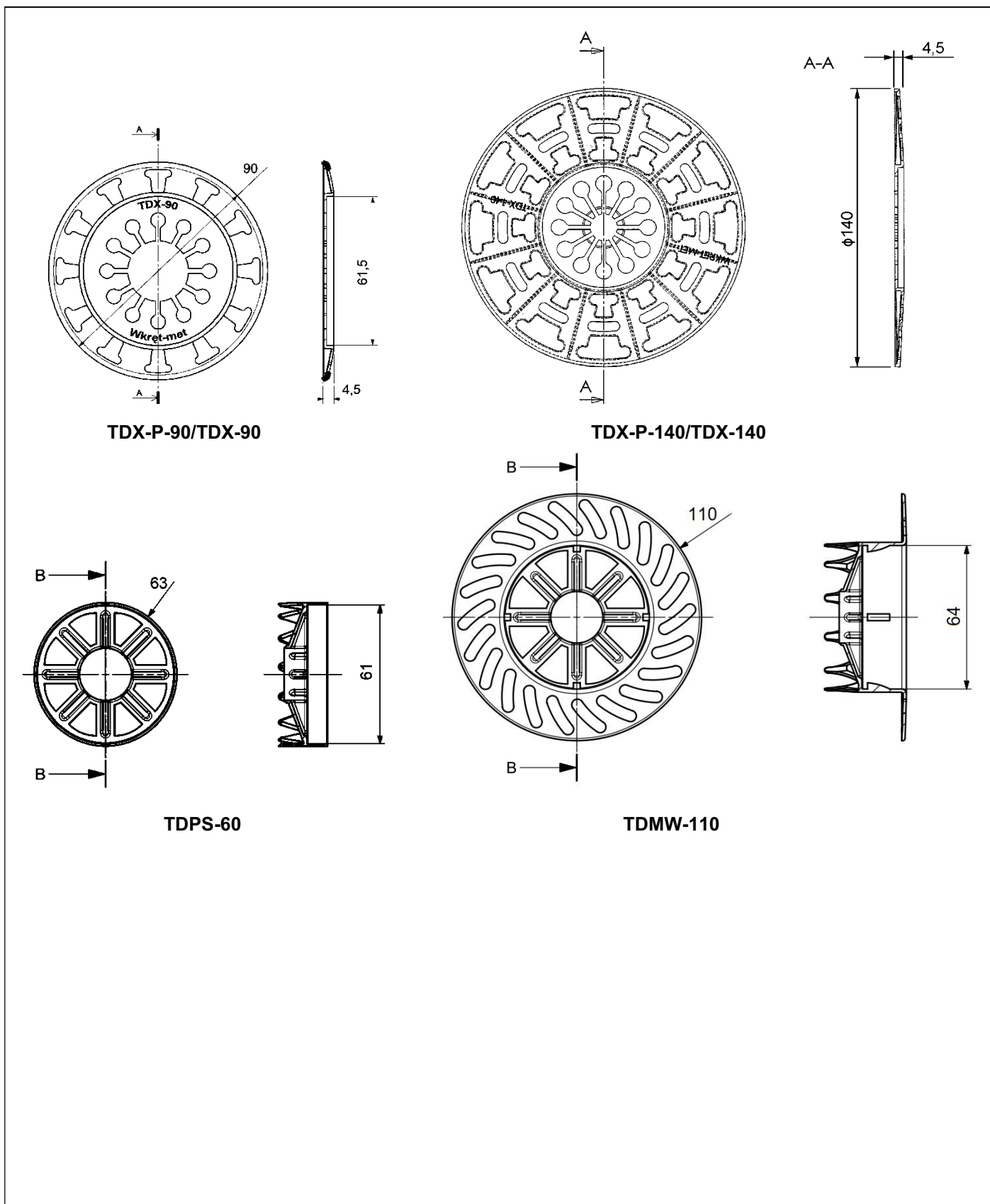

ThermoDrive-V2

Product description
Additional slip on plates with ThermoDrive-V2

Annex A 4

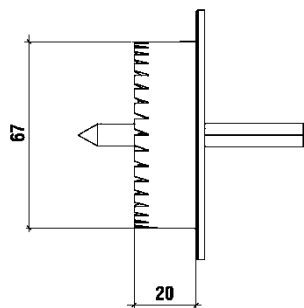

**Special drill tool WK-FT/WK-FM
for immersed installation**

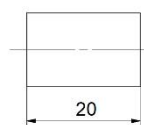
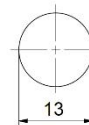
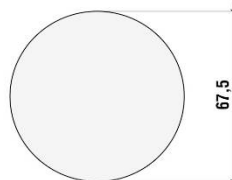

Insulation cap KS/ KSG or EDMW and KSV

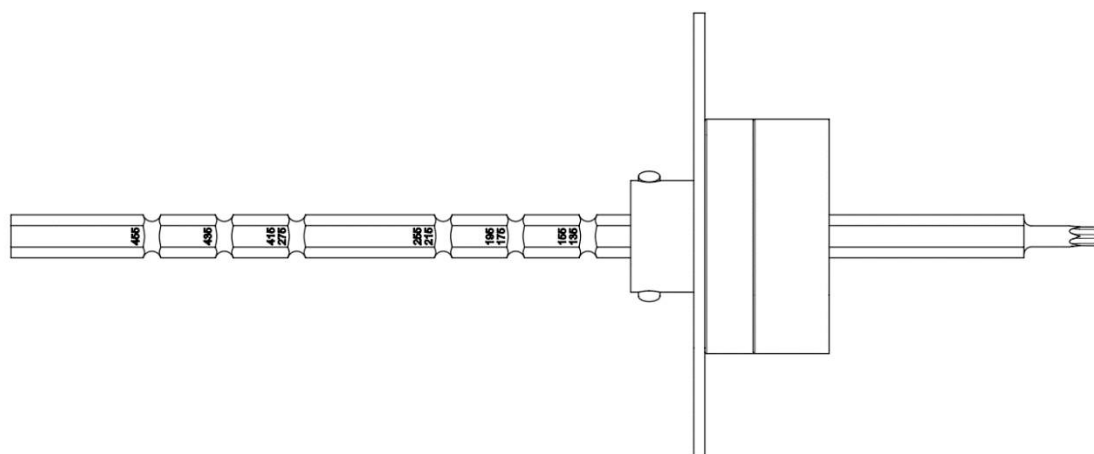

Additional mounting tool ThermoDrive-V2

ThermoDrive-V2

Product description

Additional tools and insulation caps

Annex A 5

Specifications of intended use

Anchorage subject to:

- The anchor may only be used for transmission of wind suction loads and shall not be used for the transmission of dead loads of the thermal insulation composite system.

Base materials:

- Compacted normal weight concrete without fibres, strength classes \geq C12/15 (base material group A), according to Annex C 1
- Solid masonry (base material group B), according to Annex C 1
- Hollow or perforated masonry (base material group C), according Annex C 1, C 2
- Lightweight aggregate concrete (base material group D), according to Annex C 3
- Autoclaved aerated concrete (base material group E), according to Annex C 3
- For other base materials of the base material groups A, B, C, D or E the characteristic resistance of the anchor may be determined by job site tests according to EOTA Technical Report TR 051 edition April 2018.

Temperature Range:

- 0°C to +40°C (max. short term temperature +40°C and max. long term temperature +24°C)

Design:

- The anchorages are designed under the responsibility of an engineer experienced in anchorages and masonry work with the partial safety factors $\gamma_M = 2,0$ and $\gamma_F = 1,5$ if there are no other national regulations.
- Verifiable calculation notes and drawings are prepared taking account of the loads to be anchored. The position of the anchor is indicated on the design drawings.
- Fasteners are only to be used for multiple fixings of thermal insulation composite systems.

Installation:

- Hole drilling by the drill modes according to Annex C 1
- Anchor installation carried out by appropriately qualified personnel and under the supervision of the person responsible for technical matters of the site.
- Installation temperature from 0°C to +40°C
- Exposure to UV due to solar radiation of the anchor not protected by rendering \leq 6 weeks

ThermoDrive-V2	Annex B 1
Intended use Specifications	

Table B1: Installation parameters for ThermoDrive-V2

		ThermoDrive-V2	ThermoDrive-V2
Base material group		ABCD	E
Drill hole diameter	d_0 [mm] =	8	8
Cutting diameter of drill bit	d_{cut} [mm] ≤	8,45	8,45
Depth of drilled hole to deepest point	h_1 [mm] ≥	35/55 ¹⁾	55/75 ¹⁾
Effective anchorage depth	h_{ef} [mm] ≥	25	45

¹⁾ immersed mount using tool ThermoDrive-V2

Table B2: Anchor distances and dimensions of members

Minimum spacing	$s_{min} \geq$ [mm]	100
Minimum edge distance	$c_{min} \geq$ [mm]	100
Minimum thickness of member	$h \geq$ [mm]	100
Minimum thickness of member for thin concrete members	$h \geq$ [mm]	40

Scheme of edge distance and spacing

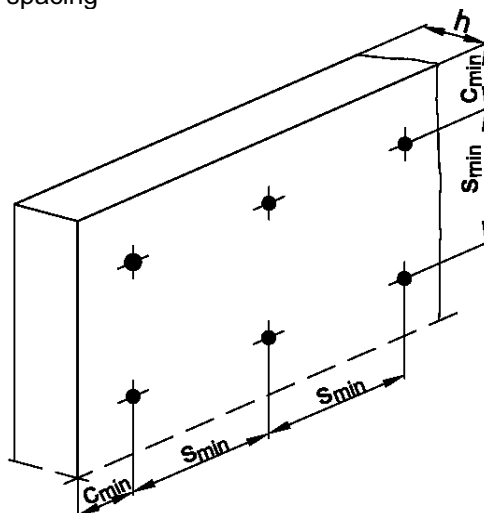

ThermoDrive-V2

Intended use

Installation parameters, minimum thickness of base material
Edge distances and spacing

Annex B 2

I. INSTALLATION INSTRUCTION - SURFACE MOUNT

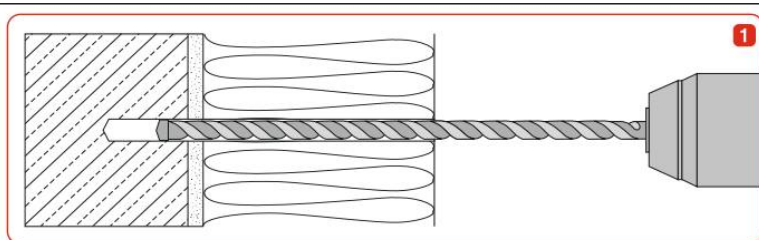

Fig.1 Drill the hole perpendicular to the substrate surface. Clean the drill hole.

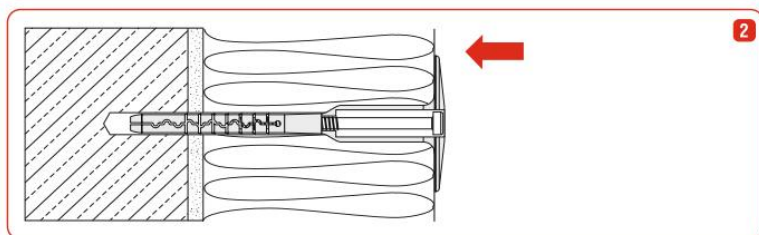

Fig.2 Place the anchor into the drill hole. The bottom side of the plate must be flush with the thermal insulation surface.

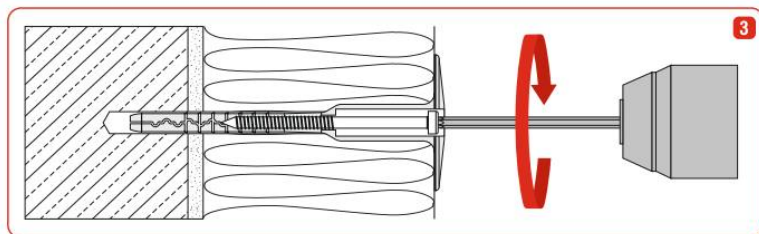

Fig. 3 and 4 Screw in the specific screw using the screwdriver bits type TX-30 with appropriate length.

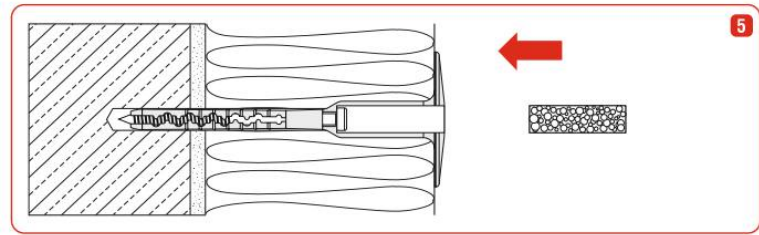
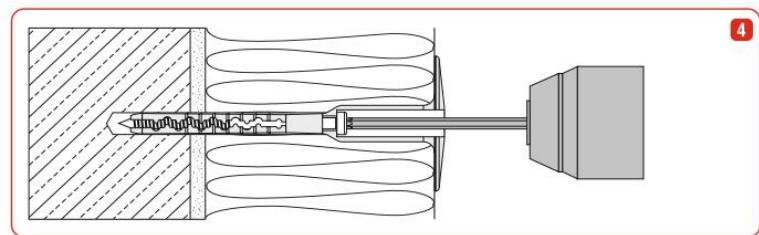

Fig. 5 Insert the KSV to be flush with the plate surface.

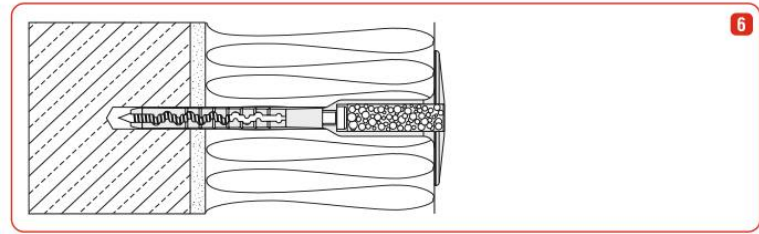

Fig. 6 Properly installed anchor.

ThermoDrive-V2

Intended use
Installation instruction - surface mount

Annex B 3

II. INSTALLATION INSTRUCTION - IMMERGED MOUNT WITH INSULATION CAP

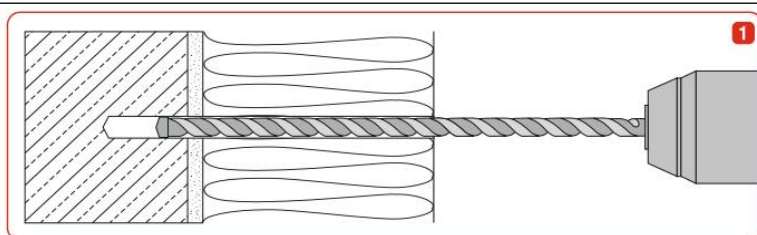

Fig. 1 Drill the hole perpendicular to the substrate surface. Clean the drill hole.

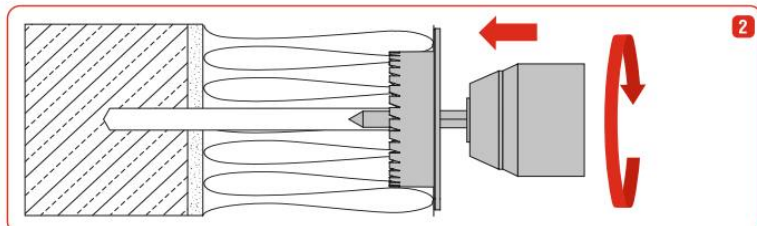

Fig. 2 Drill the recess for immersed installation with appropriate drilling tool WK-FT/WK-FM.

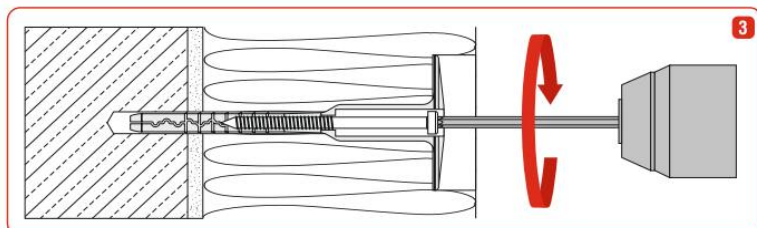

Fig. 3 and 4 Screw in the specific screw using the screwdriver bits type TX-30 with appropriate length.

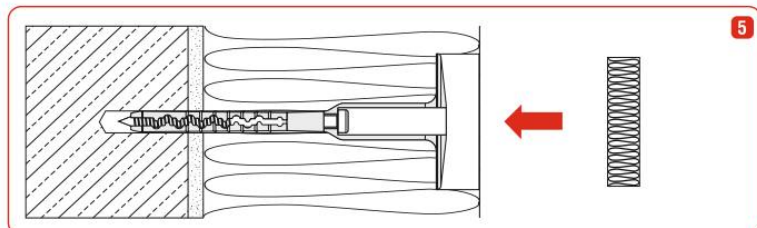
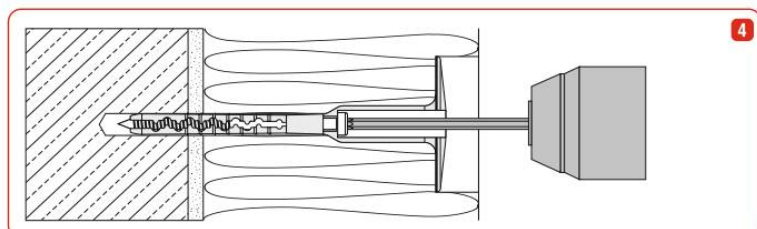

Fig. 5 Insert the insulation cap.

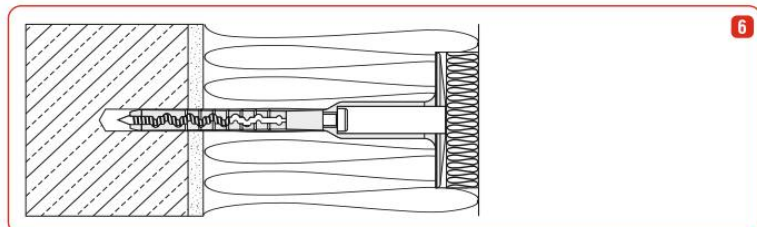

Fig. 6 Properly installed anchor.

ThermoDrive-V2

Intended use
Installation instruction - immersed mount with insulation cap

Annex B 4

III. INSTALLATION INSTRUCTION - IMMERGED MOUNT USING TOOL THERMODRIVE-V2 WITH INSULATION CAP

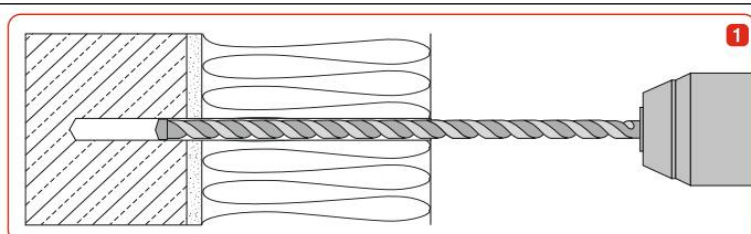

Fig. 1 Drill the hole perpendicular to the substrate surface. Clean the drill hole.

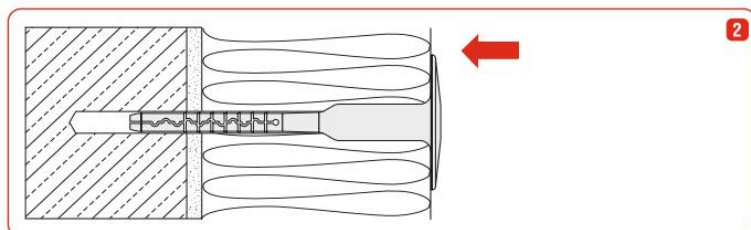

Fig. 2 Place the anchor into the drill hole. The bottom side of the plate must be flush with the thermal insulation surface.

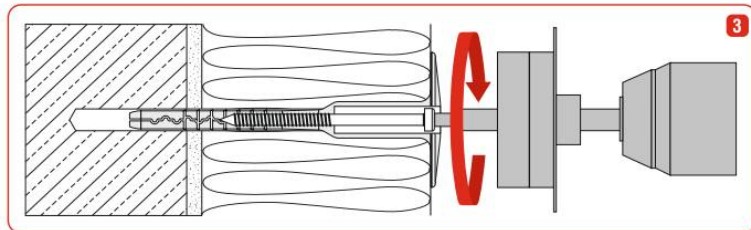

Fig. 3 and 4 Screw in the specific screw using the tool ThermoDrive-V2.

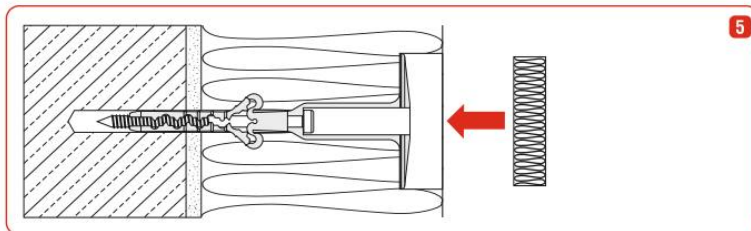
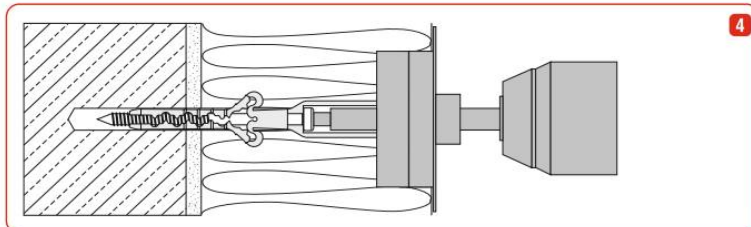

Fig. 5 Insert the insulation cap.

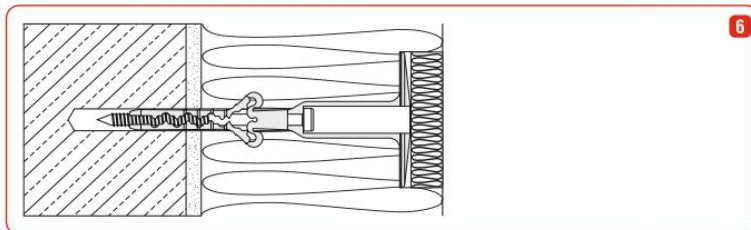

Fig. 6 Properly installed anchor.

ThermoDrive-V2

Intended use

Installation instruction - immersed mount using tool ThermoDrive-V2 with insulation cap

Annex B 5

IV. INSTALLATION INSTRUCTION - IMMERGED MOUNT WITH PLATE V2 AND INSULATION CAP

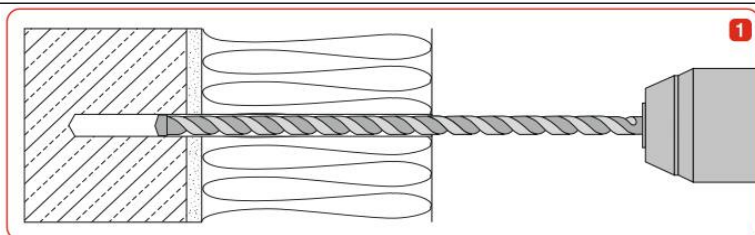

Fig. 1 Drill the hole perpendicular to the substrate surface. Clean the drill hole.

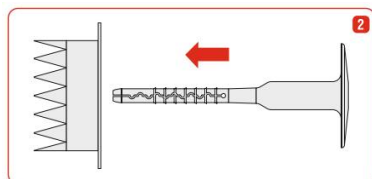

Fig. 2 Assemble anchor and PLATE TDPS or TDMW

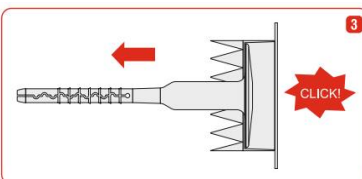

Fig. 3 Correct assembly is confirmed by a "click".

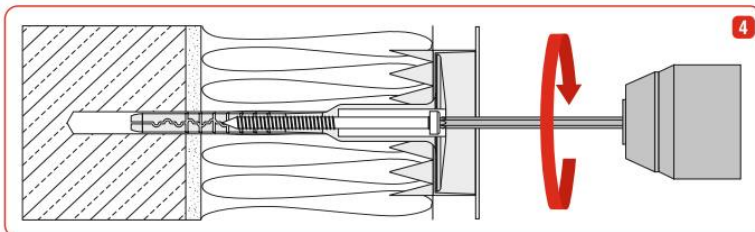

Fig. 4 and 5 Screw in the specific screw using the screwdriver bits type TX-30 with appropriate length.

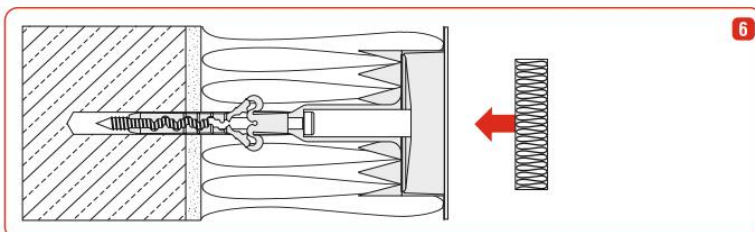
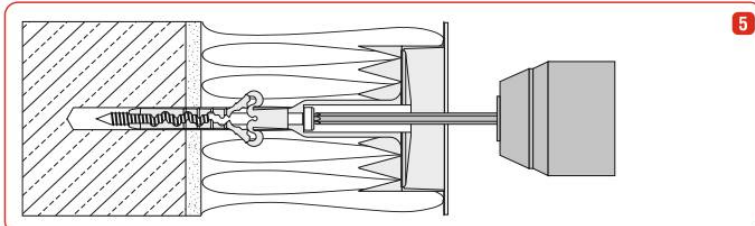

Fig. 6 Insert the insulation cap.

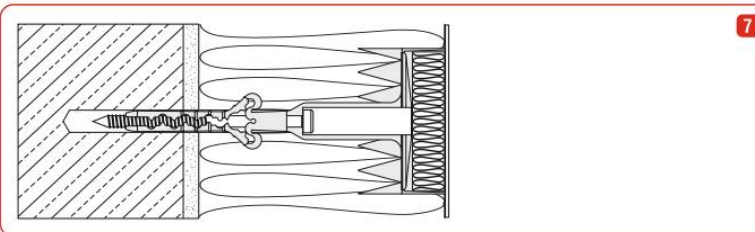

Fig. 7 Properly installed anchor.

ThermoDrive-V2

Intended use

Installation instruction - immersed mount with PLATE (TDPS or TDMW) and insulation cap

Annex B 6

Table C1: Characteristic resistance to tension loads N_{Rk} in concrete and masonry for a single anchor in kN					
Anchor type				ThermoDrive-V2	
Base materials	Bulk density ρ [kg/dm ³]	minimum compressive strength f_b [N/mm ²]	General remarks	Drill method	N_{Rk} [kN]
Concrete C12/15 as per EN 206:2013+A1:2016	$\geq 2,2$	≥ 20	Compacted normal weight concrete without fibres	hammer	1,50
Concrete C16/20 - C50/60 as per EN 206:2013+A1:2016	$\geq 2,25$	≥ 30	Compacted normal weight concrete without fibres	hammer	1,50
Thin concrete members (e.g. weather resistant skin of external wall panels) C16/20 – C50/60	$\geq 2,0$	≥ 20	Compacted normal weight concrete without fibres Thickness of the thin skin: 100 mm > h \geq 40 mm	hammer	1,50
Clay bricks MZ as per EN 771-1:2011+A1:2015	$\geq 2,0$	≥ 20	Vertically perforation up to 15 %	hammer	1,50
Calcium silicate bricks KS as per EN 771-1:2011+A1:2015	$\geq 2,0$	≥ 20	Vertically perforation up to 15 %	hammer	1,50
Calcium silicate hollow block KSL as per EN 771-1:2011+A1:2015 	$\geq 1,6$	≥ 12	Vertically perforation more than 15 % and less than 50 %, outer web thickness ≥ 20 mm	hammer	1,50
Vertically perforated clay bricks Porotherm 25 	$\geq 0,8$	≥ 15	Vertically perforation more than 15 % and less than 50 %, outer web thickness ≥ 12 mm	rotary	1,20
Vertically perforated ceramic block MAX 250 	$\geq 0,8$	≥ 15	Vertically perforation more than 15 % and less than 50 %, outer web thickness ≥ 12 mm	rotary	1,20
ThermoDrive-V2				Annex C1	
Performances Characteristic resistance of ThermoDrive-V2 – part 1					

Table C1: Characteristic resistance to tension loads N_{Rk} in concrete and masonry for a single anchor in kN					
Anchor type					ThermoDrive-V2
Base materials	Bulk density ρ [kg/dm ³]	minimum compressive strength f_b [N/mm ²]	General remarks	Drill method	N_{Rk} [kN]
Vertically perforated clay bricks Hlz as per EN 771-1:2011+A1:2015 	$\geq 1,2$	≥ 12	Vertically perforation more than 15 % and less than 50 %, outer web thickness ≥ 12 mm	rotary	1,50
Tekno Amer Block PK17,8 	$\geq 1,5$	≥ 25	Exterior web thickness ≥ 30 mm	rotary	1,50
Tekno Amer Block PK19 	$\geq 1,1$	≥ 20	Exterior web thickness ≥ 30 mm	rotary	1,50
Lightweight concrete hollow blocks HBL as per EN 771-3:2011+A1:2015 	$\geq 0,8$	≥ 2	Vertically perforation more than 15 % and less than 50 %, outer web thickness ≥ 30 mm	rotary	1,50
ThermoDrive-V2					Annex C 2
Performances Characteristic resistance of ThermoDrive-V2 – part 2					

Table C1: Characteristic resistance to tension loads N_{Rk} in concrete and masonry for a single anchor in kN						
Anchor type					ThermoDrive-V2	
Base materials	Bulk density ρ [kg/dm ³]	minimum compressive strength f_b [N/mm ²]	General remarks	Drill method	N_{Rk} [kN]	
Autoclaved concrete blocks as per EN 771-4:2011+A1:2015	≥ 0,35	≥ 2		rotary	1,20	
Autoclaved concrete blocks as per EN 771-4:2011+A1:2015	≥ 0,65	≥ 5		rotary	1,50	
Lightweight concrete blocks LAC as per EN 1520:2011 / EN 771-3:2011+A1:2015	≥ 0,88	≥ 5		rotary	1,20	
ThermoDrive-V2					Annex C 3	
Performances Characteristic resistance of ThermoDrive-V2 – part 3						

Table C2: Point thermal transmittance according EOTA Technical Report TR 025:2016-05

anchor type	insulation thickness h_D [mm]	point thermal transmittance χ [W/K]
ThermoDrive-V2 surface mount	100	0,001
ThermoDrive-V2 surface mount	110-400	0,002
ThermoDrive-V2 surface mount	410-430	0,001
ThermoDrive-V2 immersed mount	100-450	0,001

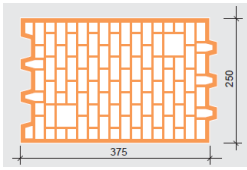
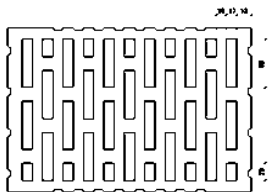
Table C3: Plate stiffness according EOTA Technical Report TR 026:2016-05

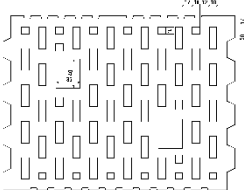
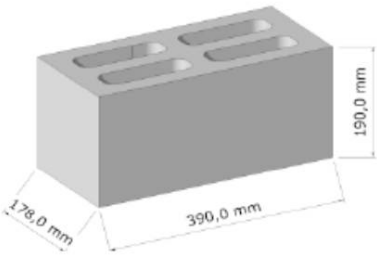
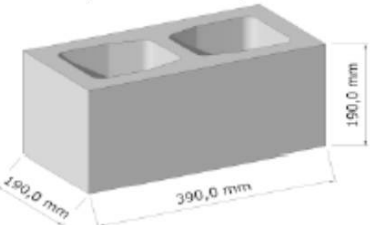
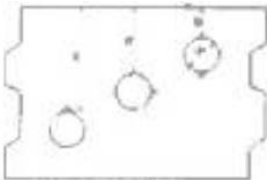
anchor type	diameter of the anchor plate [mm]	load resistance of the anchor plate [kN]	plate stiffness [kN/mm]
ThermoDrive-V2	60	2,6	1,0

Table C4: Displacements ThermoDrive-V2

Base materials (refer Table C1)	Bulk density ρ [kg/dm ³]	Minimum compressive Strength f_b [N/mm ²]	Tension load N [kN]	Displacements $\Delta\delta_N$ [mm]
Concrete C12/15	≥ 2,2	≥ 20	0,5	0,44
Concrete C16/20 ÷ C50/60	≥ 2,25	≥ 30	0,5	0,47
Thin concrete members (e.g. weather resistant skins) C16/20 – C50/60	≥ 2,0	≥ 20	0,5	0,47
Clay bricks MZ	≥ 2,0	≥ 20	0,5	0,68
Calcium silicate bricks KS	≥ 2,0	≥ 20	0,5	0,66
Calcium silicate hollow block KSL	≥ 1,6	≥ 12	0,5	0,53
Vertically perforated clay bricks Porothersm 25	≥ 0,8	≥ 15	0,4	0,64
Vertical perforated ceramic bricks MAX 250	≥ 0,8	≥ 15	0,4	0,68
Vertically perforated clay bricks HLZ	≥ 1,2	≥ 12	0,5	0,62
Tekno Amer Block PK17,8	≥ 1,5	≥ 25	0,5	0,58
Tekno Amer Block PK19	≥ 1,1	≥ 20	0,5	0,48
Lightweight concrete hollow blocks HBL	≥ 0,8	≥ 2	0,5	0,65
Autoclaved concrete blocks	≥ 0,35	≥ 2	0,4	0,68
Autoclaved concrete blocks	≥ 0,65	≥ 5	0,5	0,56
Lightweight concrete blocks LAC	≥ 0,88	≥ 5	0,4	0,44

ThermoDrive-V2

Performances

Point thermal transmittance, plate stiffness, displacements

Annex C 4