

Public-law institution jointly founded by the federal states and the Federation

European Technical Assessment Body
for construction products



European Technical Assessment

ETA-25/0981
of 19 January 2026

English translation prepared by DIBt - Original version in German language

General Part

Technical Assessment Body issuing the European Technical Assessment:

Deutsches Institut für Bautechnik

Trade name of the construction product

Injection system TILCA TIM V+, TIM V+ Frost for masonry

Product family
to which the construction product belongs

Metal Injection anchors for use in masonry

Manufacturer

EFCO Befestigungstechnik AG
Grabenstraße 1
8606 NÄNIKON
SCHWEIZ

Manufacturing plant

Plant 2

This European Technical Assessment
contains

77 pages including 3 annexes which form an integral part
of this assessment

This European Technical Assessment is
issued in accordance with Article 95(4) of
Regulation (EU) No 2024/3110, on the basis of

EAD 330076-01-0604

The European Technical Assessment is issued by the Technical Assessment Body in its official language. Translations of this European Technical Assessment in other languages shall fully correspond to the original issued document and shall be identified as such.

Communication of this European Technical Assessment, including transmission by electronic means, shall be in full. However, partial reproduction may only be made with the written consent of the issuing Technical Assessment Body. Any partial reproduction shall be identified as such.

This European Technical Assessment may be withdrawn by the issuing Technical Assessment Body, in particular pursuant to information by the Commission in accordance with Article 36(3) of Regulation (EU) No 2024/3110.

Specific Part

1 Technical description of the product

The "Injection system TILCA TIM V+, TIM V+ Frost for masonry" is a bonded anchor (injection type) consisting of a mortar cartridge with injection mortar TILCA® TIM V+ or TILCA® TIM V+ Frost, a perforated sleeve and an anchor rod with hexagon nut and washer or an Internal threaded rod. The steel elements are made of zinc coated steel, stainless steel or high corrosion resistant steel.

The anchor rod is placed into a drilled hole filled with injection mortar and is anchored via the bond between steel element, injection mortar and masonry and mechanical interlock.

The product description is given in Annex A.

2 Specification of the intended use in accordance with the applicable European Assessment Document

The performances given in Section 3 are only valid if the fastener is used in compliance with the specifications and conditions given in Annex B.

The verifications and assessment methods on which this European Technical Assessment is based lead to the assumption of a working life of the fastener of at least 50 years. The indications given on the working life cannot be interpreted as a guarantee given by the producer, but are to be regarded only as a means for choosing the right products in relation to the expected economically reasonable working life of the works.

3 Performance of the product and references to the methods used for its assessment

3.1 Mechanical resistance and stability (BWR 1)

Essential characteristic	Performance
Characteristic resistance for static and quasi-static loading	See Annexes B 5, B 6 C 1 to C 56
Characteristic resistance and displacements for seismic loading	No performance assessed

3.2 Safety in case of fire (BWR 2)

Essential characteristic	Performance
Reaction to fire	Class A1
Resistance to fire under tension and shear loading with and without lever arm. Minimum edge distances and spacing	See Annexes C2, C7, C8, C13, C14, C17, C18, C19, C20, C37, C38, C43, C44, C45, C46, C51 and C52

3.3 Hygiene, health and the environment (BWR 3)

Essential characteristic	Performance
Content, emission and/or release of dangerous substances	No performance assessed

4 Assessment and verification of constancy of performance (AVCP) system applied, with reference to its legal base

In accordance with the European Assessment Document EAD 330076-01-0604 the applicable European legal act is: [97/177/EC].

The system to be applied is: 1

5 Technical details necessary for the implementation of the AVCP system, as provided for in the applicable European Assessment Document

Technical details necessary for the implementation of the AVCP system are laid down in the control plan deposited at Deutsches Institut für Bautechnik.

Issued in Berlin 19 January 2026 by Deutsches Institut für Bautechnik

Dipl.-Ing. Beatrix Wittstock
Head of Section

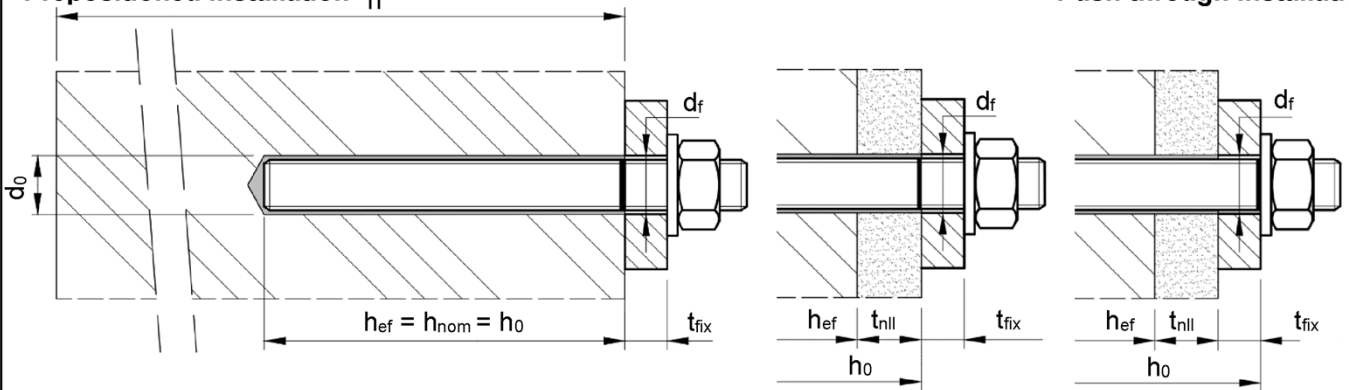
beglaubigt:
Baderschneider

Installation in solid brick with or without non-loadbearing layer

Threaded rod M8 up to M16 / Internal threaded rod IG-M6 up to IG-M10 without sleeve

Prepositioned installation

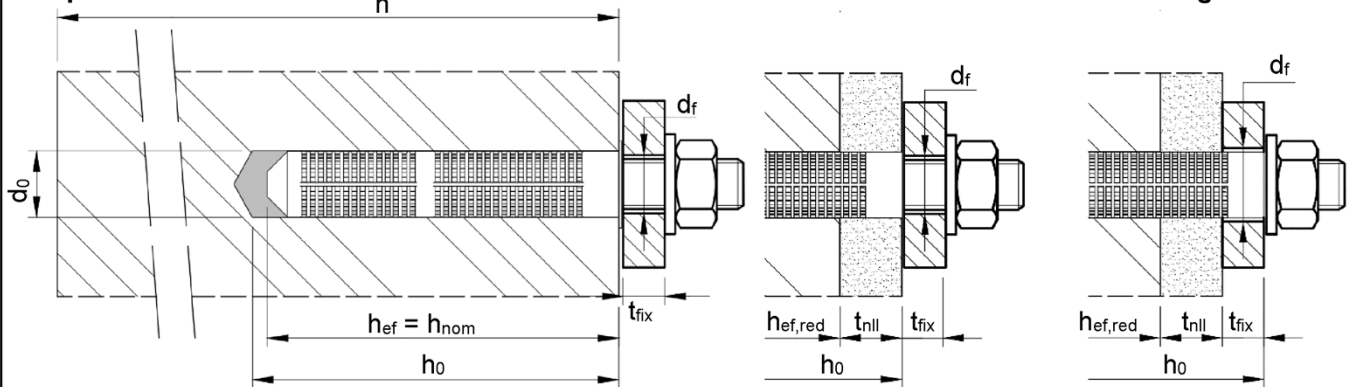
Push through installation



Threaded rod M8 up to M16 / Internal threaded rod IG-M6 up to IG-M10 with sleeve

Prepositioned installation

Push through installation

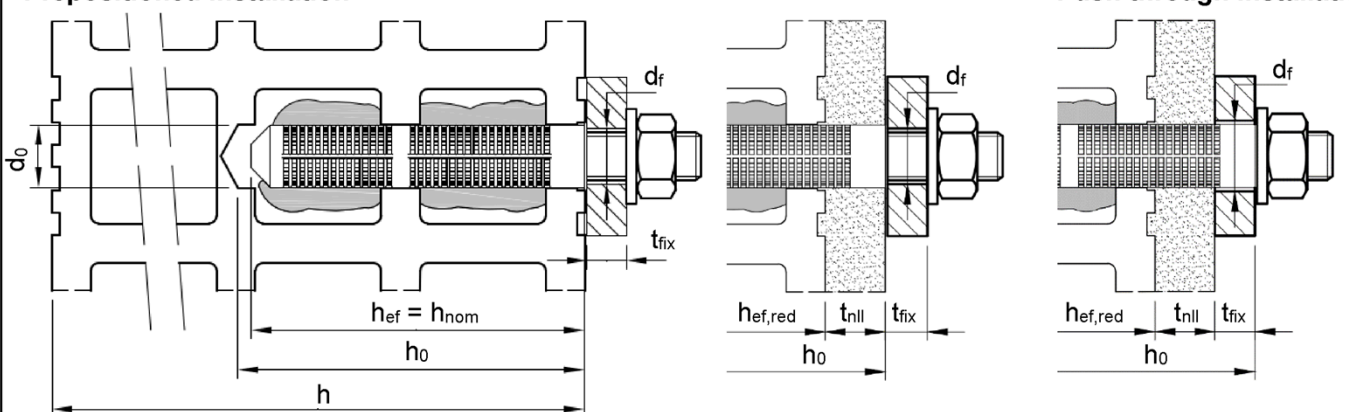


Installation in hollow brick with or without non-loadbearing layer

Threaded rod M8 up to M16 / Internal threaded rod IG-M6 up to IG-M10 with sleeve

Prepositioned installation

Push through installation



For push through installation the annular gap between rod and fixture must be filled with mortar

h_{ef} = effective anchorage depth
 h_{nom} = overall anchor embedment depth
 h_0 = drill hole depth
 h = thickness of masonry member

d_0 = nominal drill hole diameter
 d_f = diameter clearance hole
 t_{fix} = thickness of fixture
 t_{nll} = thickness of non-loadbearing layer

Injection system TILCA TIM V+, TIM V+ Frost for masonry

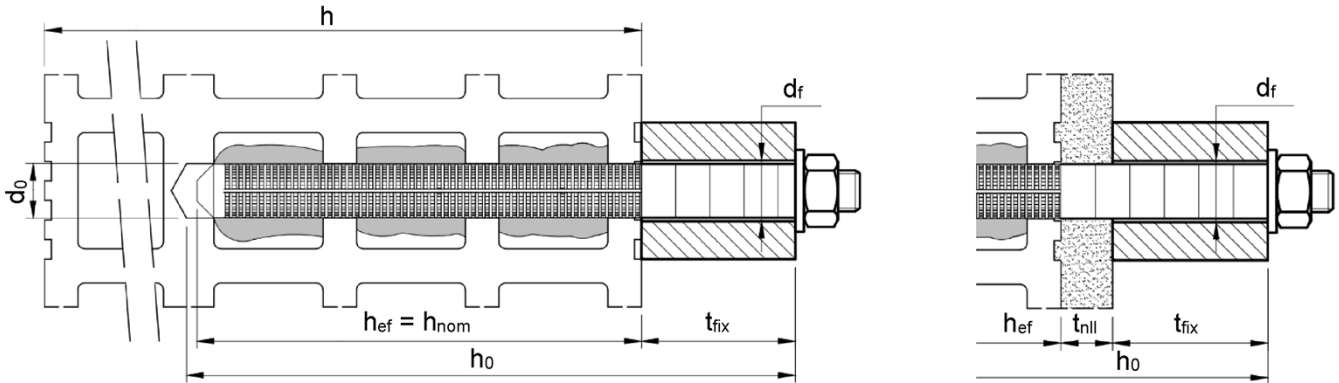
Product description
Installed condition

Annex A 1

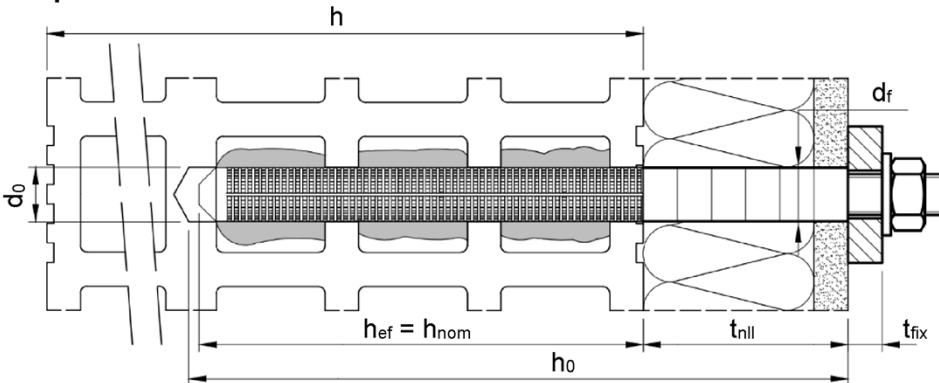
Installation in hollow brick with or without non-loadbearing layer and / or thermal insulation

Threaded rod M8 and M10 / Internal threaded rod IG-M6 with sleeve SH 16x130/330

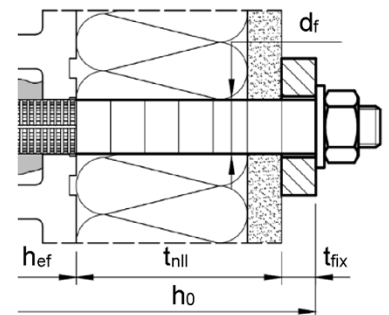
Push through installation



Prepositioned installation



Push through installation



h_{ef} = effective anchorage depth
 h_{nom} = overall anchor embedment depth
 h_0 = drill hole depth
 h = thickness of masonry member

d_0 = nominal drill hole diameter
 d_f = diameter clearance hole
 t_{fix} = thickness of fixture
 t_{nll} = thickness of non-loadbearing layer

Injection system TILCA TIM V+, TIM V+ Frost for masonry

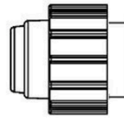
Product description
Installed condition

Annex A 2

Cartridge system

Coaxial Cartridge:

150 ml, 160ml, 280 ml,
300 ml up to 333 ml and
380 ml up to 420 ml



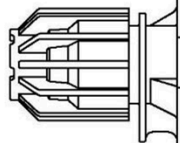
Imprint:

TILCA® TIM V+ or TILCA® TIM V+ Frost

Processing and safety instructions, shelf life, charge number, manufacturer's information, quantity information

Side-by-Side Cartridge:

235 ml, 345 ml up to 360 ml
and 825 ml



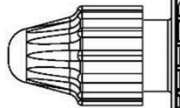
Imprint:

TILCA® TIM V+ or TILCA® TIM V+ Frost

Processing and safety instructions, shelf life, charge number, manufacturer's information, quantity information

Foil Tube Cartridge:

165 ml and 300 ml

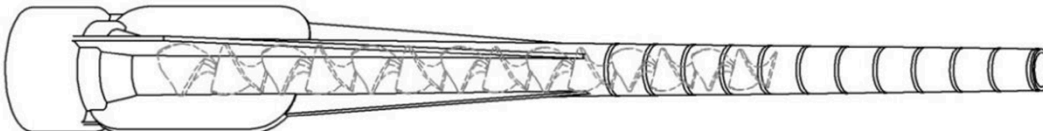


Imprint:

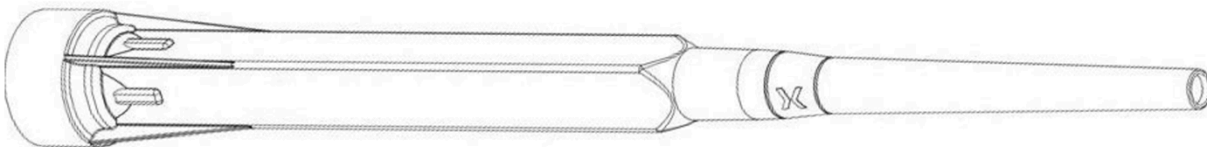
TILCA® TIM V+ or TILCA® TIM V+ Frost

Processing and safety instructions, shelf life, charge number, manufacturer's information, quantity information

Static mixer TIM SM 14



Static mixer TIM SM Quadro



Mixer extension VL



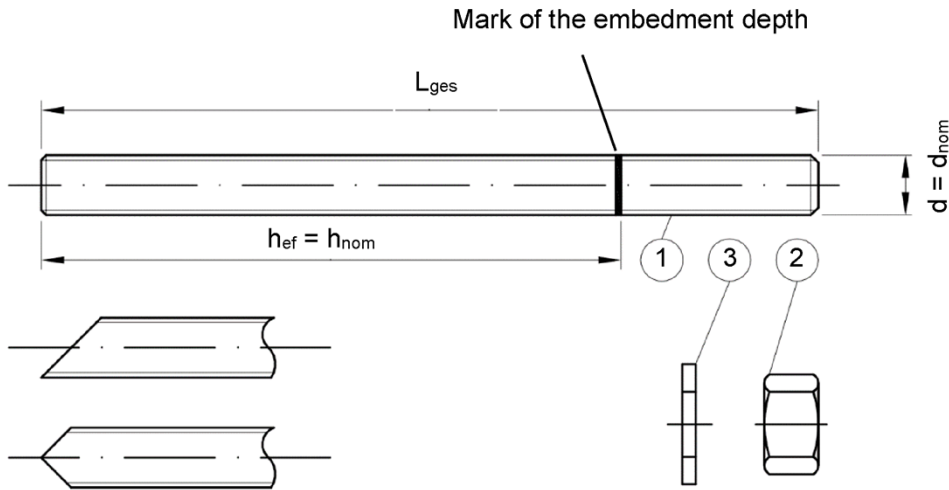
Injection system TILCA TIM V+, TIM V+ Frost for masonry

Product description

Injection system

Annex A 3

Threaded rod M8 up to M16 with washer and hexagon nut

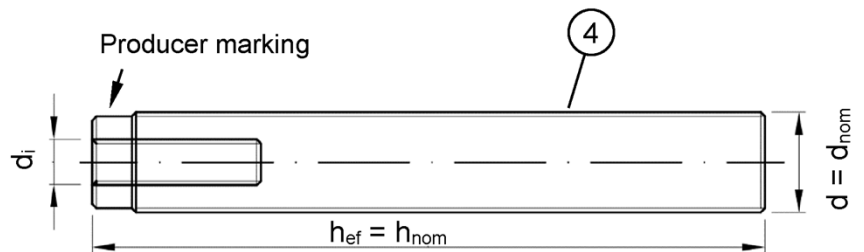
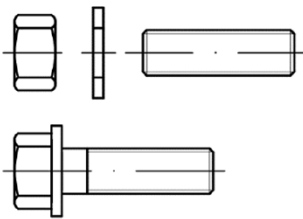



Commercial standard rod with:

- Materials, dimensions and mechanical properties acc. to Table A1
- Inspection certificate 3.1 acc. to EN 10204:2004. The document shall be stored
- Marking of embedment depth


Internal threaded rod IG-M6 to IG-M10

Threaded rod or screw



Producer marking: e.g.  M8

 Marking Internal thread (optional)

 Mark

M8 Thread size (Internal thread)

A4 additional mark for stainless steel

HCR additional mark for high-corrosion resistance steel

-8 additional mark for property class 8.8

Injection system TILCA TIM V+, TIM V+ Frost for masonry

Product description

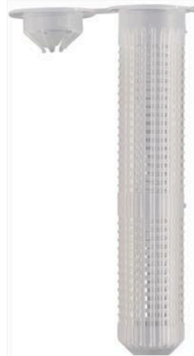
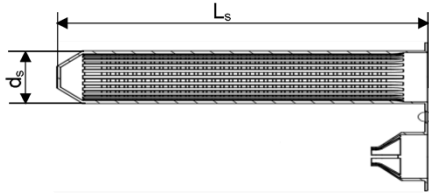
Threaded rod and Internal threaded rod

Annex A 4

Table A1: Materials						
Part	Designation	Material				
Steel, zinc plated (Steel acc. to EN ISO 683-4:2018 or EN 10263:2017)						
- zinc plated $\geq 5 \mu\text{m}$ acc. to EN ISO 4042:2022 or						
- hot-dip galvanised $\geq 40 \mu\text{m}$ acc. to EN ISO 1461:2022 and EN ISO 10684:2004+AC:2009 or						
- sherardized $\geq 45 \mu\text{m}$ acc. to EN ISO 17668:2016						
1	Threaded rod	Property class	Characteristic steel ultimate tensile strength	Characteristic steel yield strength	Elongation at fracture	
		acc. to EN ISO 898-1:2013	4.6	$f_{uk} = 400 \text{ N/mm}^2$	$f_{yk} = 240 \text{ N/mm}^2$	$A_5 > 8\%$
			4.8	$f_{uk} = 400 \text{ N/mm}^2$	$f_{yk} = 320 \text{ N/mm}^2$	$A_5 > 8\%$
			5.6	$f_{uk} = 500 \text{ N/mm}^2$	$f_{yk} = 300 \text{ N/mm}^2$	$A_5 > 8\%$
			5.8	$f_{uk} = 500 \text{ N/mm}^2$	$f_{yk} = 400 \text{ N/mm}^2$	$A_5 > 8\%$
8.8	$f_{uk} = 800 \text{ N/mm}^2$	$f_{yk} = 640 \text{ N/mm}^2$	$A_5 > 8\%$			
2	Hexagon nut	acc. to EN ISO 898-2:2022	4	for anchor rod class 4.6 or 4.8		
			5	for anchor rod class 5.6 or 5.8		
			8	for anchor rod class 8.8		
3	Washer	Steel, zinc plated, hot-dip galvanised or sherardized (e.g.: EN ISO 887:2006, EN ISO 7089:2000, EN ISO 7093:2000 or EN ISO 7094:2000)				
4	Internal threaded anchor rod ²⁾	Property class	Characteristic steel ultimate tensile strength	Characteristic steel yield strength	Elongation at fracture	
		acc. to EN ISO 898-1:2013	5.8	$f_{uk} = 500 \text{ N/mm}^2$	$f_{yk} = 400 \text{ N/mm}^2$	$A_5 > 8\%$
			8.8	$f_{uk} = 800 \text{ N/mm}^2$	$f_{yk} = 640 \text{ N/mm}^2$	$A_5 > 8\%$
Stainless steel A2 (Material 1.4301 / 1.4307 / 1.4311 / 1.4567 or 1.4541, acc. to EN 10088-1:2023)						
Stainless steel A4 (Material 1.4401 / 1.4404 / 1.4571 / 1.4362 or 1.4578, acc. to EN 10088-1:2023)						
High corrosion resistance steel (Material 1.4529 or 1.4565, acc. to EN 10088-1: 2023)						
1	Threaded rod ¹⁾	Property class	Characteristic steel ultimate tensile strength	Characteristic steel yield strength	Elongation at fracture	
		acc. to EN ISO 3506-1:2020	50	$f_{uk} = 500 \text{ N/mm}^2$	$f_{yk} = 210 \text{ N/mm}^2$	$A_5 > 8\%$
			70	$f_{uk} = 700 \text{ N/mm}^2$	$f_{yk} = 450 \text{ N/mm}^2$	$A_5 > 8\%$
80	$f_{uk} = 800 \text{ N/mm}^2$	$f_{yk} = 600 \text{ N/mm}^2$	$A_5 > 8\%$			
2	Hexagon nut ¹⁾	acc. to EN ISO 3506-1:2020	50	for anchor rod class 50		
			70	for anchor rod class 70		
			80	for anchor rod class 80		
3	Washer	Stainless steel A2, A4 or HCR (e.g.: EN ISO 887:2006, EN ISO 7089:2000, EN ISO 7093:2000 or EN ISO 7094:2000)				
4	Internal threaded anchor rod ²⁾	Property class	Characteristic steel ultimate tensile strength	Characteristic steel yield strength	Elongation at fracture	
		acc. to EN ISO 3506-1:2020	50	$f_{uk} = 500 \text{ N/mm}^2$	$f_{yk} = 210 \text{ N/mm}^2$	$A_5 > 8\%$
			70	$f_{uk} = 700 \text{ N/mm}^2$	$f_{yk} = 450 \text{ N/mm}^2$	$A_5 > 8\%$
1) Property class 80 only for stainless steel A4 and HCR						
2) Using internally threaded anchor rod screws and threaded rods (incl. nut and washer) must at least correspond to the material and strength class of the internally threaded anchor rod used.						
Plastic perforated sleeve						
Sieve sleeve SH			Polypropylene (PP)			
Injection system TILCA TIM V+, TIM V+ Frost for masonry					Annex A 5	
Product description Materials						

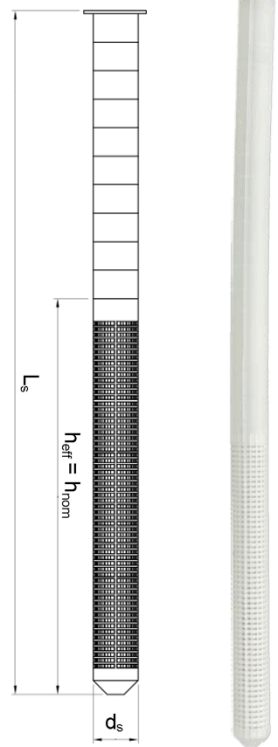
Tabelle A2: Perforated sleeve

SH 12x80
SH 16x85
SH 20x85



SH 16x130 / 330

For installations
through insulation
up to a thickness of
20 cm or push
through installation



SH 16x130
SH 20x130
SH 20x200

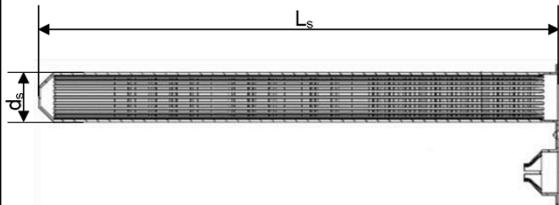


Table A3: Sleeve dimensions

Sleeve			
Size [mm]	d_s [mm]	L_s [mm]	$h_{ef} = h_{nom}$ [mm]
SH 12x80	12	80	80
SH 16x85	16	85	85
SH 16x130	16	130	130
SH 16x130 / 330 ¹⁾	16	330	130
SH 20x85	20	85	85
SH 20x130	20	130	130
SH 20x200	20	200	200

¹⁾ In Annexes C4 – C56 this sleeve is covered with SH 16x130

Table A4: Steel parts

Anchor rod			
Size [mm]	$d = d_{nom}$ [mm]	d_i [mm]	l_{ges} [mm]
IG-M6 ¹⁾	10	6	with sleeve: $h_{ef} - 5\text{mm}$ without sleeve: h_{ef}
IG-M8 ¹⁾	12	8	
IG-M10 ¹⁾	16	10	
M8	8	-	$h_{ef} + t_{fix} + 9,5$
M10	10	-	$h_{ef} + t_{fix} + 11,5$
M12	12	-	$h_{ef} + t_{fix} + 17,5$
M16	16	-	$h_{ef} + t_{fix} + 20,0$

¹⁾ Internal threaded rod with metric external thread

Injection system TILCA TIM V+, TIM V+ Frost for masonry

Product description
Sleeves and steel parts

Annex A 6

Specifications of intended use										
Anchorage subject to:	Static and quasi-static loads, fire exposure under tension and shear loads M8 up to M16, IG-M6 up to IG-M10 (with and without sleeve)									
Base material	<table border="0"> <tr> <td>Masonry group b:</td> <td>Solid brick masonry</td> <td>Annex B 2</td> </tr> <tr> <td>Masonry group c:</td> <td>Hollow brick masonry</td> <td>Annex B 2 to B 4</td> </tr> <tr> <td>Masonry group d:</td> <td>Autoclaved Aerated Concrete</td> <td>Annex B 2</td> </tr> </table>	Masonry group b:	Solid brick masonry	Annex B 2	Masonry group c:	Hollow brick masonry	Annex B 2 to B 4	Masonry group d:	Autoclaved Aerated Concrete	Annex B 2
	Masonry group b:	Solid brick masonry	Annex B 2							
Masonry group c:	Hollow brick masonry	Annex B 2 to B 4								
Masonry group d:	Autoclaved Aerated Concrete	Annex B 2								
Mortar strength class of the masonry M2,5 at minimum according to EN 998-2:2016. For other bricks in solid masonry and in hollow masonry or in autoclaved aerated concrete, the characteristic resistance of the anchor may be determined by job site tests according to EOTA TR 053, Edition July 2022 under consideration of the β -factor according to Annex C 1, Table C1.										
Hole drilling	See Annex C 4 – C 56									
Use category	Condition d/d: Installation and use in dry masonry Condition w/w: Installation and use in dry or wet masonry (incl. w/d installation in wet masonry and use in dry masonry)									
Temperature Range	T _a : - 40°C to +40°C (max. short term temperature +40°C and max. long term temperature +24°C) T _b : - 40°C to +80°C (max. short term temperature +80°C and max. long term temperature +50°C) T _a : - 40°C to +120°C (max. short term temperature +120°C and max. long term temperature +72°C)									
Note: The characteristic resistance for solid bricks and autoclaved aerated concrete are also valid for larger brick sizes and larger compressive strength of the masonry unit.										
Use conditions (Environmental conditions): <ul style="list-style-type: none"> - Structures subject to dry internal conditions (all materials). - For all other conditions according to EN 1993-1-4:2006 + A1:2015 corresponding to corrosion resistance classes to Table A1 (stainless steel and high corrosion resistant steel). 										
Design: <ul style="list-style-type: none"> - Verifiable calculation notes and drawings are prepared taking account the relevant masonry in the region of the anchorage, the loads to be transmitted and their transmission to the supports of the structure. The position of the anchor is indicated on the design drawings. - The anchorages are designed in accordance with the EOTA TR 054, Edition July 2022, under the responsibility of an engineer experienced in anchorages and masonry work. - Applies to all bricks if no other values are specified: <ul style="list-style-type: none"> • $N_{RK} = N_{RK,b} = N_{RK,p} = N_{RK,b,c} = N_{RK,p,c}$ • $V_{RK} = V_{RK,b} = V_{RK,c,II} = V_{RK,c,I}$ - For the calculation of pulling out a brick under tension loading $N_{RK,pb}$ or pushing out a brick under shear loading $V_{RK,pb}$ see EOTA Technical Report TR 054, Edition July 2022. - $N_{RK,s}$, $V_{RK,s}$ and $M^0_{RK,s}$ see Annexes C 1 - C 2 - For application with sleeve with drill bit size ≤ 15mm installed in joints not filled with mortar: <ul style="list-style-type: none"> • $N_{RK,p,j} = 0,18 * N_{RK,p}$ and $N_{RK,b,j} = 0,18 * N_{RK,b}$ ($N_{RK,p} = N_{RK,b}$ see Annex C 4 to C 56) • $V_{RK,c,j} = 0,15 * V_{RK,c}$ and $V_{RK,b,j} = 0,15 * V_{RK,b}$ ($V_{RK,b}$ see Annex C 4 to C 56; and $V_{RK,c}$ see Annex C 3) - Application without sleeve installed in joints not filled with mortar is not allowed. 										
Installation: <ul style="list-style-type: none"> - Anchor Installation carried out by appropriately qualified personnel and under the supervision of the person responsible for technical matters of the site. 										
Injection system TILCA TIM V+, TIM V+ Frost for masonry										
Intended use Specifications	Annex B 1									






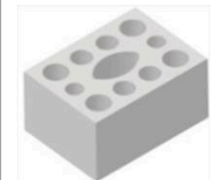
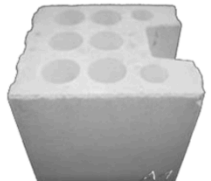

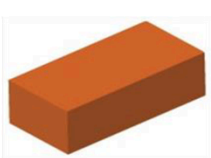
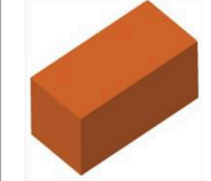
Table B1: Overview brick types and properties with corresponding fastening elements (Anchor and Sleeves)							
Naming Density [kg/dm ³] Dimensions LxBxH [mm] Annex	Picture	Anchor rods	Perforated sleeve	Naming Density [kg/dm ³] Dimensions LxBxH [mm] Annex	Picture	Anchor rods	Perforated sleeve
Hollow light weight concrete brick acc. to EN 771-4:2011+A1:2015				Hollow light weight concrete brick acc. to EN 771-3:2011+A1:2015			
AAC $\rho = 0,35 - 0,60$ $\geq 499 \times 240 \times 249$ Table C4 - C10		M8 - M16 IG-M6 - IG-M10	12x80 16x85 16x130 20x85 20x130 20x200	VBL $\rho \geq 0,6$ $\geq 240 \times 300 \times 113$ Table C187 - C193		M8 - M16 IG-M6 - IG-M10	12x80 16x85 16x130 20x85 20x130 20x200
Hollow light weight concrete brick acc. to EN 771-3:2011+A1:2015							
HBL 16DF $\rho \geq 1,0$ 500x250x240 Table C172 - C179		M8 - M16 IG-M6 - IG-M10	16x85 16x130 20x85 20x130 20x200	Bloc creux B40 $\rho \geq 0,8$ 495x195x190 Table C180 - C186		M8 - M16 IG-M6 - IG-M10	16x130 20x130
Calcium silica bricks acc. to EN 771-2:2011+A1:2015							
KS $\rho \geq 2,0$ $\geq 240 \times 115 \times 71$ Table C11 - C18		M8 - M16 IG-M6 - IG-M10	12x80 16x85 16x130 20x85 20x130 20x200	KSL-3DF $\rho \geq 1,4$ 240x175x113 Table C19 - C25		M8 - M16 IG-M6 - IG-M10	16x85 16x130 20x85 20x130
KSL-8DF $\rho \geq 1,4$ 248x240x238 Table C26 - C32		M8 - M16 IG-M6 - IG-M10	16x130 20x130 20x200	KSL-12DF $\rho \geq 1,4$ 498x175x238 Table C33 - C40		M8 - M16 IG-M6 - IG-M10	16x130 20x130
Solid clay bricks acc. to EN 771-1:2011+A1:2015							
Mz-1DF $\rho \geq 2,0$ $\geq 240 \times 115 \times 55$ Table C41 - C47		M8 - M16 IG-M6 - IG-M10	12x80 16x85 16x130 20x85 20x130 20x200	Mz - 2 DF $\rho \geq 2,0$ $\geq 240 \times 115 \times 113$ Table C48 - C55		M8 - M16 IG-M6 - IG-M10	12x80 16x85 16x130 20x85 20x130 20x200
Injection system TILCA TIM V+, TIM V+ Frost for masonry					Annex B 2		
Intended use Brick types and properties with corresponding fastening elements							







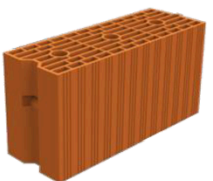





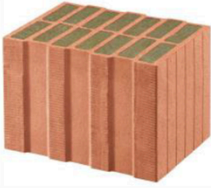



Table B1: Overview brick types and properties with corresponding fastening elements (Anchor and Sleeves) (Continued)							
Naming Density [kg/dm³] Dimensions LxBxH [mm] Annex	Picture	Anchor rods	Perforated sleeve	Naming Density [kg/dm³] Dimensions LxBxH [mm] Annex	Picture	Anchor rods	Perforated sleeve
Hollow clay bricks acc. to EN 771-1:2011+A1:2015							
Hlz-10DF $\rho \geq 1,25$ 300x240x249 Table C56 - C63		M8 - M16 IG-M6 - IG-M10	12x80 16x85 16x130 20x85 20x130 20x200	Porotherm Homebric $\rho \geq 0,7$ 500x200x299 Table C64 - C70		M8 - M16 IG-M6 - IG-M10	12x80 16x85 16x130 20x85 20x130
BGV Thermo $\rho \geq 0,6$ 500x200x314 Table C71 - C77		M8 - M16 IG-M6 - IG-M10	12x80 16x85 16x130 20x85 20x130	Brique creuse C40 $\rho \geq 0,7$ 500x200x200 Table C92 - C98		M8 - M16 IG-M6 - IG-M10	12x80 16x85 16x130 20x85 20x130
Calibric R+ $\rho \geq 0,6$ 500x200x314 Table C78 - C84		M8 - M16 IG-M6 - IG-M10	12x80 16x85 16x130 20x85 20x130	Blocchi Leggeri $\rho \geq 0,6$ 250x120x250 Table C99 - C105		M8 - M16 IG-M6 - IG-M10	12x80 16x85 16x130 20x85 20x130
Urbanbric $\rho \geq 0,7$ 560x200x274 Table C85 - C91		M8 - M16 IG-M6 - IG-M10	12x80 16x85 16x130 20x85 20x130	Doppio Uni $\rho \geq 0,9$ 250x120x120 Table C106 - C112		M8 - M16 IG-M6 - IG-M10	12x80 16x85 16x130 20x85 20x130
Hollow clay bricks with thermal insulation acc. to EN 771-1:2011+A1:2015							
Coriso WS07 $\rho \geq 0,55$ 248x365x249 Mineral wool Table C113 - C119		M8 - M16 IG-M6 - IG-M10	12x80 16x85 16x130 20x85 20x130 20x200	T8P $\rho \geq 0,56$ 248x365x249 Perlite Table C128 - C134		M8 - M16 IG-M6 - IG-M10	12x80 16x85 16x130 20x85 20x130 20x200
T7MW $\rho \geq 0,59$ 248x365x249 Mineral wool Table C120 - C127		M8 - M16 IG-M6 - IG-M10	12x80 16x85 16x130 20x85 20x130 20x200	MZ90-G $\rho \geq 0,68$ 248x365x249 Mineral wool Table C135 - C141		M8 - M16 IG-M6 - IG-M10	12x80 16x85 16x130 20x85 20x130 20x200
Injection system TILCA TIM V+, TIM V+ Frost for masonry					Annex B 3		
Intended use Brick types and properties with corresponding fastening elements							

Table B1: Overview brick types and properties with corresponding fastening elements (Anchor and Sleeves) (Continued)							
Naming Density [kg/dm³] Dimensions LxBxH [mm] Annex	Picture	Anchor rods	Perforated sleeve	Naming Density [kg/dm³] Dimensions LxBxH [mm] Annex	Picture	Anchor rods	Perforated sleeve
Hollow clay bricks with thermal insulation acc. to EN 771-1:2011+A1:2015							
Poroton FZ7,5 $\rho \geq 0,90$ 248x365x249 Mineral wool Table C142 - C149		M8 - M16 IG-M6 - IG-M10	12x80 16x85 16x130 20x85 20x130 20x200	Poroton FZ9 $\rho \geq 0,90$ 248x365x249 Mineral wool Table C150 - C157		M8 - M16 IG-M6 - IG-M10	12x80 16x85 16x130 20x85 20x130 20x200
Poroton S9 $\rho \geq 0,85$ 248x365x249 Perlite Table C158 - C164		M8 - M16 IG-M6 - IG-M10	12x80 16x85 16x130 20x85 20x130 20x200	Thermopor TV8+ $\rho \geq 0,70$ 248x365x249 Mineral wool Table C165 - C171		M8 - M16 IG-M6 - IG-M10	12x80 16x85 16x130 20x85 20x130 20x200
Injection system TILCA TIM V+, TIM V+ Frost for masonry					Annex B 4		
Intended use Brick types and properties with corresponding fastening elements							

Anchor size			M8	M10	IG-M6	M12	IG-M8	M16	IG-M10	
Nominal drill hole diameter	d_0	[mm]	10	12		14		18		
Drill hole depth	h_0	[mm]	$h_{ef} + t_{fix}^{1)}$							
Effective anchorage depth	h_{ef}	[mm]	80	≥ 90		≥ 100		≥ 100		
Diameter of clearance hole in the fixture	Prepositioned installation	$d_f \leq$	[mm]	9	12	7	14	9	18	12
	Push through installation	$d_f \leq$	[mm]	12	14	14	16	16	20	20
Maximum installation torque	T_{inst}	[Nm]	See Annexes C 4 – C 56							
Minimum thickness of member	h_{min}	[mm]	$h_{ef} + 30$							
Minimum spacing	s_{min}	[mm]	See Annexes C 4 – C 56							
Minimum edge distance	c_{min}	[mm]								

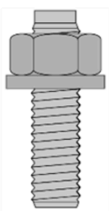



1) Consider t_{fix} in case of push through installation.

Anchor size			M8	M8 / M10 / IG-M6				M12 / M16 / IG-M8 / IG-M10		
Perforated sleeve SH			12x80	16x85	16x130	16x130/330	20x85	20x130	20x200	
Nominal drill hole diameter	d_0	[mm]	12	16	16	16	20	20	20	
Drill hole depth	h_0	[mm]	85	90	135	330	90	135	205	
Effective anchorage depth	h_{ef}	[mm]	80	85	130	130	85	130	200	
Diameter of clearance hole in the fixture	$d_f \leq$	[mm]	9	7 (IG-M6) / 9 (M8) / 12 (M10)			9 (IG-M8) / 12 (IG-M10) / 14 (M12) / 18 (M16)			
Maximum installation torque	T_{inst}	[Nm]	See Annexes C 4 – C 56							
Minimum thickness of member	h_{min}	[mm]	115	115	195	195	115	195	240	
Minimum spacing	s_{min}	[mm]	See Annexes C 4 – C 56							
Minimum edge distance	c_{min}	[mm]								

Injection system TILCA TIM V+, TIM V+ Frost for masonry	Annex B 5
Intended use Installation parameters	

Table B4: Installation parameters in solid and hollow bricks (with perforated sleeve) for prepositioned installation through non-load-bearing layers and/or push-through installation				M8 / M10 / IG-M6		M12 / M16 / IG-M8 / IG-M10	
Anchor size							
Perforated sleeve SH				16x130	16x130/330	20x130	20x200
Nominal drill hole diameter	d_0	[mm]	16	16	20	20	
Drill hole depth	h_0	[mm]	$h_{ef} + 5\text{mm} + t_{nll} + t_{fix}$ ¹⁾				
Effective embedment depth	Prepositioned installation	h_{ef}	[mm]	130	130	130	200
	Push through installation	h_{ef}	[mm]	85	130	85	85
Maximum thickness of non-loadbearing layer	$\max t_{nll}$	[mm]	45	200	45	115	
Diameter of clearance hole in the fixture	Prepositioned installation	$d_f \leq$	[mm]	7 (IG-M6) / 9 (M8) / 12 (M10)		9 (IG-M8) / 12 (IG-M10) / 14 (M12) / 18 (M16)	
	Push through installation	$d_f \leq$	[mm]	18		22	
Maximum installation torque	T_{inst}	[Nm]	See Annexes C 4 – C 56				
Minimum thickness of member	h_{min}	[mm]	195 (115)	195	195 (115)	240 (115)	
Minimum spacing	s_{min}	[mm]	See Annexes C 4 – C 56				
Minimum edge distance	c_{min}	[mm]	See Annexes C 4 – C 56				
¹⁾ Consider t_{nll} and/or t_{fix} in case of non-loadbearing layers and/or push through installation.							
Injection system TILCA TIM V+, TIM V+ Frost for masonry						Annex B 6	
Intended use Installation parameters							

Table B5: Parameter cleaning and installation tools

					
Anchor rod	Perforated sleeve	d_0 Drill bit - \varnothing HD, CA	d_b Brush - \varnothing		$d_{b,min}$ min. Brush - \varnothing
[mm]		[mm]		[mm]	[mm]
Autoaerated ACC and solid masonry (without sleeve)					
M8	-	10	RBS10	12	10,5
M10	-	12	RBS12	14	12,5
M12	-	14	RBS14	16	14,5
M16	-	18	RBS18	20	18,5
Solid and hollow masonry (with sleeve)					
M8	SH 12x80	12	RBS12	14	12,5
M8 / M10 / IG-M6	SH 16x85	16	RBS16	18	16,5
	SH 16x130				
	SH 16x130/330				
M12 / M16 / IG-M8 / IG-M10	SH 20x85	20	RBS20	22	20,5
	SH 20x130				
	SH 20x200				

Cleaning and installation tools

Hand pump

(Volume \geq 750 ml)



Compressed air tool

(min 6 bar)



Brush RBS



Brush extension RBL



Injection system TILCA TIM V+, TIM V+ Frost for masonry

Intended use

Cleaning and installation tools

Annex B 7

Table B6: Working and curing time - TILCA® TIM V+

Temperature in base material			Maximum working time	Minimum curing time ¹⁾
T			t_{work}	t_{cure}
- 10 °C	to	- 6 °C	90 min ²⁾	24 h
- 5 °C	to	- 1 °C	90 min	14 h
0 °C	to	+ 4 °C	45 min	7 h
+ 5 °C	to	+ 9 °C	25 min	2 h
+ 10 °C	to	+ 19 °C	15 min	80 min
+ 20 °C	to	+ 24 °C	6 min	45 min
+ 25 °C	to	+ 29 °C	4 min	25 min
+ 30 °C	to	+ 39 °C	2 min	20 min
+ 40 °C			1,5 min	15 min
Cartridge temperature			+5°C to +40°C	

1) The minimum curing time is only valid for dry base material. In wet base material the curing time must be doubled.

2) Cartridge temperature must be at minimum +15°C

Table B7: Working and curing time - TILCA® TIM V+ Frost

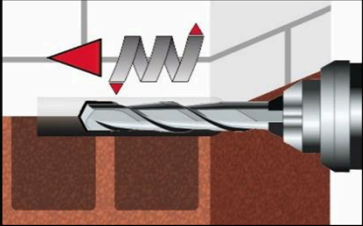
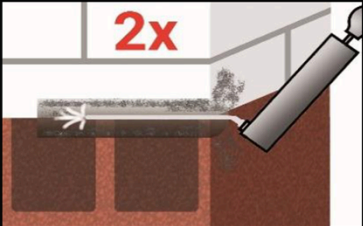
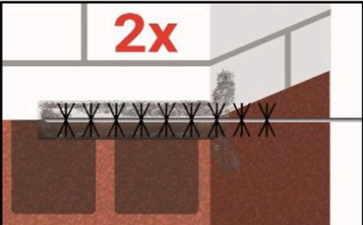
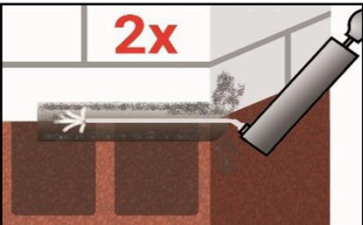
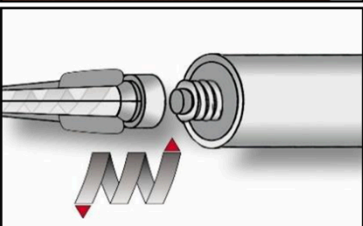
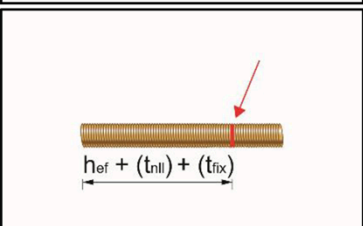
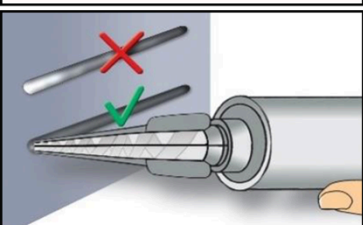
Temperature in base material			Maximum working time	Minimum curing time ¹⁾
T			t_{work}	t_{cure}
- 20 °C	to	- 16 °C	75 min	24 h
- 15 °C	to	- 11 °C	55 min	16 h
- 10 °C	to	- 6 °C	35 min	10 h
- 5 °C	to	- 1 °C	20 min	5 h
0 °C	to	+ 4 °C	10 min	2,5 h
+ 5 °C	to	+ 9 °C	6 min	80 min
+ 10 °C			6 min	60 min
Cartridge temperature			-20°C to +10°C	

1) The minimum curing time is only valid for dry base material. In wet base material the curing time must be doubled.

Injection system TILCA TIM V+, TIM V+ Frost for masonry

Intended use
Working and curing time

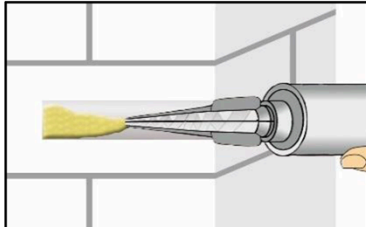
Annex B 8

Installation instructions	
	<p>1. Drill a hole to the required embedment depth with drilling method according to Annex C 4 - C 56. Drill bit diameter according to Table B5.</p>
	<p>2a. Blow the bore hole clean minimum 2x from the bottom or back by hand pump or compressed air tool (Annex B 7). For applications in solid masonry with a bore hole depth $h_0 > 100\text{mm}$ cleaning with compressed air is required.</p>
	<p>2b. Attach brush RBS according to Table B5 to a drilling machine or a cordless screwdriver. Brush the bore hole minimum 2x with brush over the entire embedment depth in a twisting motion (if necessary, use a brush extension RBL).</p>
	<p>2c. Finally blow the bore hole clean minimum 2x from the bottom or back by hand pump or compressed air tool (Annex B 7). For applications in solid masonry with a bore hole depth $h_0 > 100\text{mm}$ cleaning with compressed air is required.</p>
	<p>3. Screw on static-mixing nozzle TIM SM 14 / TIM SM Quadro, and load the cartridge into an appropriate dispensing tool. If necessary, cut off the foil tube clip before use. For every working interruption longer than the maximum working time t_{work} (Annex B 8) as well as for new cartridges, a new static-mixer shall be used.</p>
	<p>4. Mark setting position on the anchor rod. Consider t_{nll} and/or t_{fix} in case of installation through non-loadbearing layers and/or push through installation. The anchor rod shall be free of dirt, grease, oil or other foreign material.</p>
	<p>5. Not proper mixed mortar is not sufficient for fastening. Dispense and discard mortar until a uniform grey colour is shown (at least 3 full strokes; for foil tube cartridges at least 6 full strokes).</p>

Injection system TILCA TIM V+, TIM V+ Frost for masonry	Annex B 9
Intended use Installation instructions	

Installation instructions (continuation)

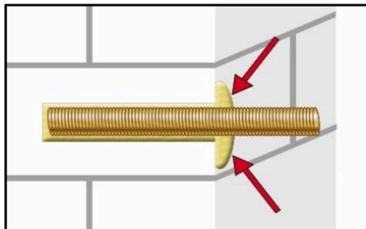
Installation without sleeve



6. Starting at bottom of the hole and fill the hole up to approximately two-thirds with adhesive. (If necessary, a mixer nozzle extension VL shall be used.) Slowly withdraw of the static mixing nozzle avoid creating air pockets. Observe the temperature related working time t_{work} (Annex B 8).

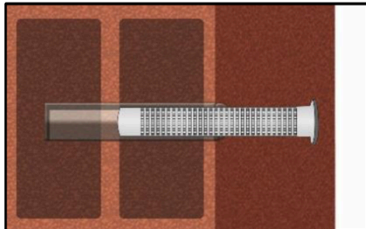


7. Insert the anchor rod while turning slightly up to the embedment mark.

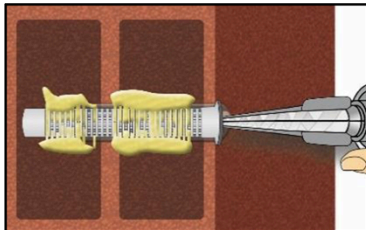


8. Annular gap between anchor rod and base material must be completely filled with mortar. For push through installation the annular gap between anchor rod and fixture must be filled with mortar. Otherwise, the installation must be repeated starting from step 6 before the maximum working time t_{work} has expired.

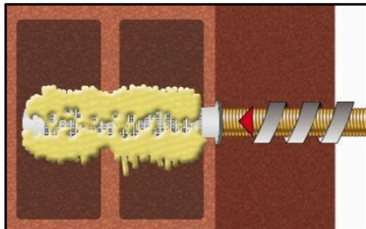
Installation with sleeve



6. Insert the perforated sleeve into the hole flush with the surface of the masonry. Never modify the sleeve in anchoring area (h_{ef}). For installation with sleeve SH 16x130/330 through a non-load-bearing layer and/or fixture the clamping area may be reduced to the thickness of the non-load-bearing layer and/or attachment.



7. Starting from the bottom or back fill the sleeve with mortar. (If necessary, a mixer nozzle extension VL shall be used.) Refer to the cartridge label or the technical data sheet for the exact amount of mortar. For push-through installation through the fixture the sleeve must also be completely filled with mortar up to the fixture. Observe the temperature related working time t_{work} (Annex B 8).



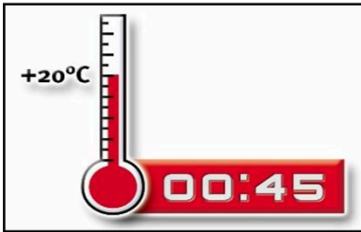
8. Insert the anchor rod with a slight twist up to the mark

Injection system TILCA TIM V+, TIM V+ Frost for masonry

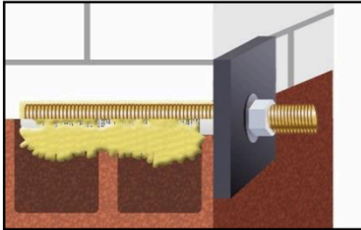
Intended use
Installation instructions (continuation)

Annex B 10

Installation instructions (continuation)



9. Temperature related curing time t_{cure} (Annex B 8) must be observed. Do not move or load the fastener during curing time.



10. Install the fixture by using a calibrated torque wrench. Observe maximum installation torque (Annex C 4 to C 56).

Injection system TILCA TIM V+, TIM V+ Frost for masonry

Intended use
Installation instructions (continuation)

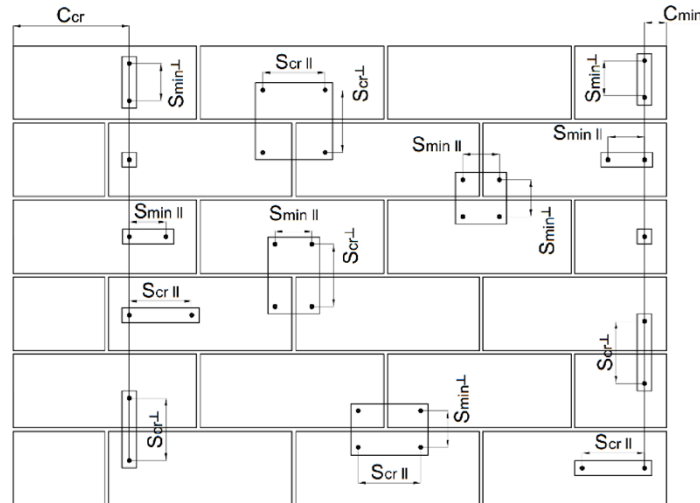
Annex B 11

Table C1: β-factor for job-site testing under tension loading									
Base material	anchor size	Perforated sleeve SH	Anchorage depth	β -Factor					
				T _a : 40°C / 24°C		T _b : 80°C / 50°C		T _c : 120°C / 72°C	
			h_{ef}	d/d	w/d w/w	d/d	w/d w/w	d/d	w/d w/w
Autoclaved aerated concrete	all sizes	with and without SH	all	0,95	0,86	0,81	0,73	0,81	0,73
Calcium silica bricks	$d_0 \leq 14$ mm	with SH	all	0,93	0,80	0,87	0,74	0,65	0,56
	$d_0 \geq 16$ mm			0,93	0,93	0,87	0,87	0,65	0,65
	$d_0 \leq 14$ mm	without SH	≤ 100 mm	0,93	0,80	0,87	0,74	0,65	0,56
	$d_0 \geq 16$ mm			0,93	0,93	0,87	0,87	0,65	0,65
	all sizes			> 100 mm	0,93	0,56	0,87	0,52	0,65
Clay Bricks	all sizes	with SH	all	0,86	0,86	0,86	0,86	0,73	0,73
		without SH	≤ 100 mm	0,93	0,80	0,87	0,74	0,65	0,56
		without SH	> 100 mm	0,86	0,43	0,86	0,43	0,73	0,37
Concrete bricks	$d_0 \leq 12$ mm	with and without SH	all	0,93	0,80	0,87	0,74	0,65	0,56
	$d_0 \geq 16$ mm			0,93	0,93	0,87	0,87	0,65	0,65

Table C2: Characteristic steel resistance										
Anchor size				M8	M10	M12	M16	IG-M6	IG-M8	IG-M10
Cross section area		A_s	[mm ²]	36,6	58	84,3	157	-	-	-
Characteristic tension resistance, Steel failure ¹⁾										
Steel, Property class	4.6 and 4.8	$N_{Rk,s}$	[kN]	15 (13)	23 (21)	34	63	- ³⁾	- ³⁾	- ³⁾
	5.6 and 5.8	$N_{Rk,s}$	[kN]	18 (17)	29 (27)	42	78	10	17	29
	8.8	$N_{Rk,s}$	[kN]	29 (27)	46 (43)	67	125	16	27	46
Stainless steel A2, A4 and HCR, class (A2 only class 50 and 70)	50	$N_{Rk,s}$	[kN]	18	29	42	79	- ³⁾	- ³⁾	- ³⁾
	70	$N_{Rk,s}$	[kN]	26	41	59	110	14	26	41
	80	$N_{Rk,s}$	[kN]	29	46	67	126	- ³⁾	- ³⁾	- ³⁾
Characteristic tension resistance, Partial factor ²⁾										
Steel, Property class	4.6 and 5.6	$\gamma_{Ms,N}$	[-]	2,0				- ³⁾		
	4.8, 5.8 and 8.8	$\gamma_{Ms,N}$	[-]	1,5						
Stainless steel A2, A4 and HCR, class (A2 only class 50 and 70)	50	$\gamma_{Ms,N}$	[-]	2,86				- ³⁾		
	70	$\gamma_{Ms,N}$	[-]	1,87						
	80	$\gamma_{Ms,N}$	[-]	1,6				- ³⁾		
Characteristic shear resistance, Steel failure without lever arm ¹⁾										
Steel, Property class	4.6 and 4.8	$V^0_{Rk,s}$	[kN]	7 (6)	12 (10)	17	31	- ³⁾	- ³⁾	- ³⁾
	5.6 and 5.8	$V^0_{Rk,s}$	[kN]	9 (8)	15 (13)	21	39	5	9	15
	8.8	$V^0_{Rk,s}$	[kN]	15 (13)	23 (21)	34	63	8	14	23
Stainless steel A2, A4 and HCR, class (A2 only class 50 and 70)	50	$V^0_{Rk,s}$	[kN]	9	15	21	39	- ³⁾	- ³⁾	- ³⁾
	70	$V^0_{Rk,s}$	[kN]	13	20	30	55	7	13	20
	80	$V^0_{Rk,s}$	[kN]	15	23	34	63	- ³⁾	- ³⁾	- ³⁾
Injection system TILCA TIM V+, TIM V+ Frost for masonry							Annex C 1			
Performances										
β -factors for job site testing under tension load Characteristic steel resistance under tension and shear load										

Table C2: Characteristic steel resistance (continuation)										
Anchor size			M8	M10	M12	M16	IG-M6	IG-M8	IG-M10	
Cross section area		A_s [mm ²]	36,6	58	84,3	157	-	-	-	
Characteristic shear resistance, Steel failure with lever arm¹⁾										
Steel, Property class	4.6 and 4.8	$M^0_{Rk,s}$ [Nm]	15 (13)	30 (27)	52	133	– ³⁾	– ³⁾	– ³⁾	
	5.6 and 5.8	$M^0_{Rk,s}$ [Nm]	19 (16)	37 (33)	65	166	8	19	37	
	8.8	$M^0_{Rk,s}$ [Nm]	30 (26)	60 (53)	105	266	12	30	60	
Stainless steel A2, A4 and HCR, class (A2 only class 50 and 70)	50	$M^0_{Rk,s}$ [Nm]	19	37	66	167	– ³⁾	– ³⁾	– ³⁾	
	70	$M^0_{Rk,s}$ [Nm]	26	52	92	232	11	26	52	
	80	$M^0_{Rk,s}$ [Nm]	30	59	105	266	– ³⁾	– ³⁾	– ³⁾	
Characteristic shear resistance, Partial factor²⁾										
Steel, Property class	4.6 and 5.6	$\gamma_{Ms,V}$ [-]	1,67				– ³⁾			
	4.8, 5.8 and 8.8	$\gamma_{Ms,V}$ [-]	1,25				– ³⁾			
Stainless steel A2, A4 and HCR, class (A2 only class 50 and 70)	50	$\gamma_{Ms,V}$ [-]	2,38				– ³⁾			
	70	$\gamma_{Ms,V}$ [-]	1,56				– ³⁾			
	80	$\gamma_{Ms,V}$ [-]	1,33				– ³⁾			
<p>1) Values are only valid for the given stress area A_s. Values in brackets are valid for undersized threaded rods with smaller stress area A_s for hot-dip galvanised threaded rods according to EN ISO 10684:2004+AC:2009.</p> <p>2) in absence of national regulation</p> <p>3) Fastener type not part of the ETA</p>										
Table C3: Characteristic steel resistance under fire exposure¹⁾										
Anchor size			M8	M10	M12	M16	IG-M6	IG-M8	IG-M10	
Characteristic tension resistance, Steel failure										
Steel, Property class 5.8, and higher; Stainless steel A2, A4 and HCR, class 50 and higher	R30	$N_{Rk,s,fi}$ [kN]	1,1	1,7	3,0	5,7	0,3	1,1	1,7	
	R60	$N_{Rk,s,fi}$ [kN]	0,9	1,4	2,3	4,2	0,2	0,9	1,4	
	R90	$N_{Rk,s,fi}$ [kN]	0,7	1,0	1,6	3,0	0,2	0,7	1,0	
	R120	$N_{Rk,s,fi}$ [kN]	0,5	0,8	1,2	2,2	0,1	0,5	0,8	
Characteristic shear resistance, Steel failure without lever arm										
Steel, Property class 5.8, and higher; Stainless steel A2, A4 and HCR, class 50 and higher	R30	$V_{Rk,s,fi}$ [kN]	1,1	1,7	3,0	5,7	0,3	1,1	1,7	
	R60	$V_{Rk,s,fi}$ [kN]	0,9	1,4	2,3	4,2	0,2	0,9	1,4	
	R90	$V_{Rk,s,fi}$ [kN]	0,7	1,0	1,6	3,0	0,2	0,7	1,0	
	R120	$V_{Rk,s,fi}$ [kN]	0,5	0,8	1,2	2,2	0,1	0,5	0,8	
Characteristic shear resistance, Steel failure with lever arm										
Steel, Property class 5.8, and higher; Stainless steel A2, A4 and HCR, class 50 and higher	R30	$M_{Rk,s,fi}$ [Nm]	1,1	2,2	4,7	12,0	0,2	1,1	2,2	
	R60	$M_{Rk,s,fi}$ [Nm]	0,9	1,8	3,5	9,0	0,2	0,9	1,8	
	R90	$M_{Rk,s,fi}$ [Nm]	0,7	1,3	2,5	6,3	0,1	0,7	1,3	
	R120	$M_{Rk,s,fi}$ [Nm]	0,5	1,0	1,8	4,7	0,1	0,5	1,0	
1) partial factor in case of fire is 1,0 for all steel types and load directions.										
Injection system TILCA TIM V+, TIM V+ Frost for masonry							Annex C 2			
Performances Characteristic steel resistance under tension and shear load – under fire exposure										

Spacing and edge distances



- C_{cr} = Char. Edge distance
- C_{min} = Minimum Edge distance
- $S_{cr,II}; (S_{min,II})$ = Characteristic (minimum) spacing for anchors placed parallel to horizontal joint
- $S_{cr,I}; (S_{min,I})$ = Characteristic (minimum) spacing for anchors placed perpendicular to horizontal joint

Anchor position	Load direction		
	Tension load	Shear load parallel to free edge V_{II}	Shear load perpendicular to free edge V_{\perp}
Anchors parallel to horizontal joint $S_{cr,II}; (S_{min,II})$	 $\alpha_{g,II,N}$	 $\alpha_{g,II,V_{II}}$	 $\alpha_{g,II,V_{\perp}}$
Anchors vertical to horizontal joint $S_{cr,I}; (S_{min,I})$	 $\alpha_{g,\perp,N}$	 $\alpha_{g,\perp,V_{II}}$	 $\alpha_{g,\perp,V_{\perp}}$

- $\alpha_{edge,N}$ = Reduction factor for tension loads at the free edge for $C_{min} \leq c < C_{cr}$ (single anchor)
- $\alpha_{edge,V_{\perp}}$ = Reduction factor for shear loads perpendicular to the free edge for $C_{min} \leq c < C_{cr}$ (single anchor)
- $\alpha_{edge,V_{II}}$ = Reduction factor for shear loads parallel to the free edge for $C_{min} \leq c < C_{cr}$ (single anchor)
- $\alpha_{g,II,N}$ = Group factor for anchors parallel to horizontal joint under tension load
- $\alpha_{g,\perp,N}$ = Group factor for anchors perpendicular to horizontal joint under tension load
- $\alpha_{g,II,V_{II}}$ = Group factor for anchors parallel to horizontal joint under shear load parallel to the free edge
- $\alpha_{g,\perp,V_{II}}$ = Group factor for anchors perpendicular to horizontal joint under shear load parallel to the free edge
- $\alpha_{g,II,V_{\perp}}$ = Group factor for anchors parallel to horizontal joint under shear load perpendicular to the free edge
- $\alpha_{g,\perp,V_{\perp}}$ = Group factor for anchors perpendicular to hor. joint under shear load perpendicular to the free edge

Single anchor at the edge: $N_{RK,b,c} = \alpha_{edge,N} * N_{RK,b}$ resp. $N_{RK,p,c} = \alpha_{edge,N} * N_{RK,p}$
 $V_{RK,c,II} = \alpha_{edge,V_{II}} * V_{RK,b}$
 $V_{RK,c,\perp} = \alpha_{edge,V_{\perp}} * V_{RK,b}$

Group of 2 anchors: $N_{g,RK} = \alpha_{g,N} * N_{RK,b}$ resp. $V_{g,RK,\perp} = \alpha_{g,V_{\perp}} * V_{RK,b}$ (for $c \geq C_{cr}$)
 $V_{g,RK,II} = \alpha_{g,V_{II}} * V_{RK,b}$ resp. $V_{g,RK,c,\perp} = \alpha_{g,V_{\perp}} * V_{RK,b}$ (for $c \geq C_{min}$)
 $V_{g,RK,c,II} = \alpha_{g,V_{II}} * V_{RK,b}$

Group of 4 anchors: $N_{g,RK} = \alpha_{g,II,N} * \alpha_{g,\perp,N} * N_{RK,b}$ resp. $V_{g,RK,\perp} = \alpha_{g,II,V_{\perp}} * \alpha_{g,\perp,V_{\perp}} * V_{RK,b}$ (for $c \geq C_{cr}$)
 $V_{g,RK,II} = \alpha_{g,II,V_{II}} * \alpha_{g,\perp,V_{II}} * V_{RK,b}$ resp. $V_{g,RK,c,\perp} = \alpha_{g,II,V_{\perp}} * \alpha_{g,\perp,V_{\perp}} * V_{RK,b}$ (for $c \geq C_{min}$)
 $V_{g,RK,c,II} = \alpha_{g,II,V_{II}} * \alpha_{g,\perp,V_{II}} * V_{RK,b}$

Equations depend on anchor position and load direction (see table above). Reduction factor, group factor and resistances see annex C 4 – C 56. Reduction for installation in joints see annex B 1.

Injection system TILCA TIM V+, TIM V+ Frost for masonry

Performances

Definition of the reduction- and group factors

Annex C 3

Brick type: Autoclaved aerated concrete – AAC

Table C4: Stone description

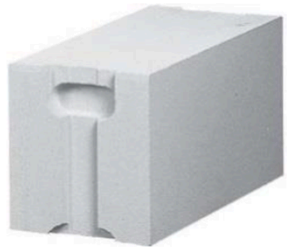
Brick type	Autoclaved aerated concrete AAC		
Density	ρ [kg/dm ³]	0,35 – 0,6	
Normalised mean compressive strength	f_b [N/mm ²]	≥ 2 , ≥ 4 or ≥ 6	
Code	EN 771-4:2011+A1:2015		
Producer (Country)	e.g. Porit (DE)		
Brick dimensions	[mm]	$\geq 499 \times 240 \times 249$	
Drilling method	Rotary drilling		

Table C5: Installation parameter

Anchor size		[-]	M8	M10	M12	M16	IG-M6	IG-M8	IG-M10
Installation torque	T_{inst}	[Nm]	≤ 5	≤ 5	≤ 10	≤ 10	≤ 5	≤ 5	≤ 10
Char. Edge distance	c_{cr}	[mm]	150 (for shear loads perpendicular to the free edge: $c_{cr} = 210$)						
Minimum Edge Distance	c_{min}	[mm]	50						
Characteristic Spacing	$s_{cr, II}$	[mm]	300						
	$s_{cr, \perp}$	[mm]	250						
Minimum Spacing	$s_{min, II}$ $s_{min, \perp}$	[mm]	50						

Table C6: Reduction factors for single anchors at the edge

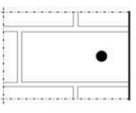
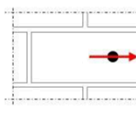
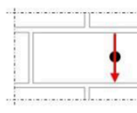
Tension load			Shear load					
			Perpendicular to the free edge			Parallel to the free edge		
	with $c \geq$	$\alpha_{edge, N}$		with $c \geq$	$\alpha_{edge, V \perp}$		with $c \geq$	$\alpha_{edge, V II}$
	50	0,85		50	0,12		50	0,70
	150	1,00		125	0,50		125	0,85
				210	1,00		150	1,00

Table C7: Factors for anchor groups under tension load

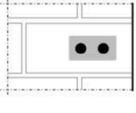
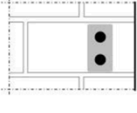
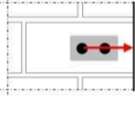
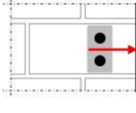
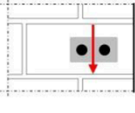
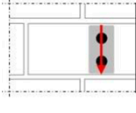
Anchor position parallel to hor. joint				Anchor position perpendicular to hor. joint			
	with $c \geq$	with $s \geq$	$\alpha_{g II, N}$		with $c \geq$	with $s \geq$	$\alpha_{g \perp, N}$
	50	50	1,10		50	50	0,75
	150	50	1,25		150	50	0,90
	150	300	2,00		150	250	2,00

Table C8: Factors for anchor groups under shear load

	Anchor position parallel to hor. joint				Anchor position perpendicular to hor. joint			
		with $c \geq$	with $s \geq$	$\alpha_{g II, V \perp}$		with $c \geq$	with $s \geq$	$\alpha_{g \perp, V \perp}$
Shear load perpendicular to the free edge		50	50	0,20		50	50	0,25
		210	50	1,60		210	50	1,80
		210	300	2,00		210	250	2,00
Shear load parallel to the free edge		with $c \geq$	with $s \geq$	$\alpha_{g II, V II}$		with $c \geq$	with $s \geq$	$\alpha_{g \perp, V II}$
		50	50	1,15		50	50	0,80
		150	50	1,60		150	50	1,10
		150	300	2,00		150	250	2,00

Injection system TILCA TIM V+, TIM V+ Frost for masonry

Performances Autoclaved Aerated Concrete - AAC

Description of the stone, Installation parameters, Reduction- and Group factors

Annex C 4

Brick type: Autoclaved aerated concrete – AAC

Table C9: Characteristic values of tension and shear load resistances

Anchor size	Perforated sleeve	Effective Anchorage depth	Characteristic Resistances with $c \geq c_{cr}$ and $s \geq s_{cr}$						
			Use condition						
			d/d			w/d w/w			d/d w/d w/w
			40°C/24°C	80°C/50°C	120°C/72°C	40°C/24°C	80°C/50°C	120°C/72°C	All temperature ranges
d_s	h_{ef}	$N_{Rk,b} = N_{Rk,p}^{1)}$			$N_{Rk,b} = N_{Rk,p}^{1)}$			$V_{Rk,b}^{1)}$	
[mm]	[mm]	[kN]							
Normalised mean compressive strength $f_b \geq 2 \text{ N/mm}^2$;					Density $\rho \geq 0,35 \text{ kg/dm}^3$				
M8	-	80	1,2	0,9	0,9	0,9	0,9	0,9	1,5
M10 / IG-M6	-	90	1,2	0,9	0,9	0,9	0,9	0,9	2,5
M12 / M16 / IG-M8 / IG-M10	-	100	2,0	1,5	1,5	1,5	1,5	1,5	2,5
M8	SH 12	80	1,2	0,9	0,9	0,9	0,9	0,9	1,5
M8 / M10/ IG-M6	SH 16	≥ 85	1,2	0,9	0,9	0,9	0,9	0,9	2,5
M12 / M16 / IG-M8 / IG-M10	SH 20	≥ 85	2,0	1,5	1,5	1,5	1,5	1,5	2,5
1) $N_{Rk,b,c} = N_{Rk,p,c}$ and $V_{Rk,c II} = V_{Rk,c I}$ according to Annex C 3									
Anchor size	Perforated sleeve	Effective Anchorage depth	Characteristic Resistances with $c \geq c_{cr}$ and $s \geq s_{cr}$						
			Use condition						
			d/d			w/d w/w			d/d w/d w/w
			40°C/24°C	80°C/50°C	120°C/72°C	40°C/24°C	80°C/50°C	120°C/72°C	All temperature ranges
d_s	h_{ef}	$N_{Rk,b} = N_{Rk,p}^{1)}$			$N_{Rk,b} = N_{Rk,p}^{1)}$			$V_{Rk,b}^{1)}$	
[mm]	[mm]	[kN]							
Normalised mean compressive strength $f_b \geq 4 \text{ N/mm}^2$;					Density $\rho \geq 0,50 \text{ kg/dm}^3$				
M8	-	80	3,0	2,5	2,0	2,5	2,0	2,0	4,5
M10 / IG-M6	-	90	3,0	2,5	2,0	2,5	2,0	2,0	7,5
M12 / M16 / IG-M8 / IG-M10	-	100	5,0	4,5	4,0	4,5	4,0	4,0	7,5
M8	SH 12	80	3,0	2,5	2,0	2,5	2,0	2,0	4,5
M8 / M10/ IG-M6	SH 16	≥ 85	3,0	2,5	2,0	2,5	2,0	2,0	7,5
M12 / M16 / IG-M8 / IG-M10	SH 20	≥ 85	5,0	4,5	4,0	4,5	4,0	4,0	7,5
1) $N_{Rk,b,c} = N_{Rk,p,c}$ and $V_{Rk,c II} = V_{Rk,c I}$ according to Annex C 3									
Injection system TILCA TIM V+, TIM V+ Frost for masonry								Annex C 5	
Performances autoclaved aerated concrete - AAC Characteristic Resistances and Displacements									

Brick type: Autoclaved aerated concrete – AAC

Anchor size	Perforated sleeve	Effective Anchorage depth	Characteristic Resistances with $c \geq c_{cr}$ and $s \geq s_{cr}$						
			Use condition						
			d/d			w/d w/w			d/d w/d w/w
			40°C/24°C	80°C/50°C	120°C/72°C	40°C/24°C	80°C/50°C	120°C/72°C	All temperature ranges
			h_{ef}	$N_{Rk,b} = N_{Rk,p}^{1)}$			$N_{Rk,b} = N_{Rk,p}^{1)}$		
[mm]	[kN]								

Normalised mean compressive strenght $f_b \geq 6 \text{ N/mm}^2$;

Density $\rho \geq 0,60 \text{ kg/dm}^3$

M8	-	80	4,0	3,5	3,0	3,5	3,0	3,0	6,0
M10 / IG-M6	-	90	4,0	3,5	3,0	3,5	3,0	3,0	10,0
M12 / M16 / IG-M8 / IG-M10	-	100	7,0	6,0	5,5	6,5	5,5	5,5	10,0
M8	SH 12	80	4,0	3,5	3,0	3,5	3,0	3,0	6,0
M8 / M10/ IG-M6	SH 16	≥ 85	4,0	3,5	3,0	3,5	3,0	3,0	10,0
M12 / M16 / IG-M8 / IG-M10	SH 20	≥ 85	7,0	6,0	5,5	6,5	5,5	5,5	10,0

1) $N_{Rk,b,c} = N_{Rk,p,c}$ and $V_{Rk,c,II} = V_{Rk,c,I}$ according to Annex C 3

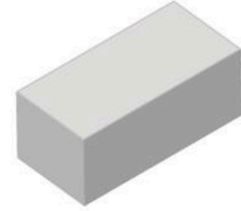
Table C10: Displacements

Anchor size	h_{ef}	δ_N / N	δ_{N0}	$\delta_{N\infty}$	δ_V / V	δ_{V0}	$\delta_{V\infty}$
	[mm]	[mm/kN]	[mm]	[mm]	[mm/kN]	[mm]	[mm]
M8 – M12 / IG-M6 – M10	all	0,1	0,1 * $N_{Rk} / 2,8$	2 * δ_{N0}	0,3	0,3 * $V_{Rk} / 2,8$	1,5 * δ_{V0}
M16	all				0,1	0,1 * $V_{Rk} / 2,8$	1,5 * δ_{V0}

Injection system TILCA TIM V+, TIM V+ Frost for masonry

Performances autoclaved aerated concrete – AAC
Characteristic Resistances and Displacements

Annex C 6



Brick type: Solid calcium silica brick KS-NF

Table C11: Stone description

Brick type	Solid calcium silica brick KS-NF	
Density	ρ [kg/dm ³]	$\geq 2,0$
Normalised mean compressive strenght	f_b [N/mm ²]	≥ 28
Conversion factor for lower compressive strenghts	$(f_b / 28)^{0,5} \leq 1,0$	
Code	EN 771-2:2011+A1:2015	
Producer (Country)	e.g. Wemding (DE)	
Brick dimensions	[mm]	$\geq 240 \times 115 \times 71$
Drilling method	Hammer drilling	

Table C12: Installation parameter

Anchor size		[-]	M8	M10	M12	M16	IG-M6	IG-M8	IG-M10
Installation torque	T_{inst}	[Nm]	≤ 10	≤ 10	≤ 15	≤ 15	≤ 10	≤ 10	≤ 10
Char. Edge distance (under fire conditions)	$c_{cr}, (c_{cr,fi})$	[mm]	150 (2 h_{ef}) (for shear loads perpendicular to the free edge: $c_{cr} = 240$)						
Minimum Edge Distance	c_{min}	[mm]	60						
Characteristic Spacing (under fire conditions)	$s_{cr, II}, (s_{cr,fi, II})$	[mm]	240 (4 h_{ef})						
	$s_{cr, \perp}, (s_{cr,fi, \perp})$	[mm]	150 (4 h_{ef})						
Minimum Spacing	$s_{min, II}, s_{min, \perp}$	[mm]	75						

Table C13: Reduction factors for single anchors at the edge

Tension load	Shear load perpendicular to free edge		Shear load parallel to free edge		
	with $c \geq$	$\alpha_{edge, N}$	with $c \geq$	$\alpha_{edge, V \perp}$	with $c \geq$
60 ¹⁾	0,50	60	0,30	60	0,60
100 ¹⁾	0,50	100	0,50	100	1,00
150 ¹⁾	1,00	240	1,00	150	1,00
180	1,00				

1) All applications, except for $h_{ef} = 200\text{mm}$ and without sleeve

Table C14: Factors for anchor groups under tension load

Anchor position parallel to hor. joint				Anchor position perpendicular to hor. joint			
	with $c \geq$	with $s \geq$	$\alpha_{g II, N}$		with $c \geq$	with $s \geq$	$\alpha_{g \perp, N}$
60 ¹⁾	75	0,70	60 ¹⁾	75	1,15		
150 ¹⁾	75	1,40	150 ¹⁾	75	2,00		
150 ¹⁾	240	2,00	150 ¹⁾	150	2,00		
180 ²⁾	75	1,00	180 ²⁾	75	1,15		
180 ²⁾	240	1,70					
240 ²⁾	240	2,00	180 ²⁾	150	2,00		

1) All applications, except for $h_{ef} = 200\text{mm}$ and without sleeve

2) Only for application with $h_{ef} = 200\text{mm}$ and without sleeve

Table C15: Factors for anchor groups under shear load

Shear load perpendicular to the free edge	Anchor position parallel to hor. joint				Anchor position perpendicular to hor. joint			
	with $c \geq$	with $s \geq$	$\alpha_{g II, V \perp}$	with $c \geq$	with $s \geq$	$\alpha_{g \perp, V \perp}$		
60	75	0,75	60	75	0,90			
150	75	2,00	150	75	2,00			
150	240	2,00	150	150	2,00			
60	75	2,00	60	75	2,00			
150	75	2,00	150	75	2,00			
150	240	2,00	150	150	2,00			

Injection system TILCA TIM V+, TIM V+ Frost for masonry

Performances solid calcium silica brick KS-NF

Description of the stone, Installation parameters, Reduction- and Group factors

Annex C 7

Brick type: Solid calcium silica brick KS-NF

Table C16: Characteristic values of tension and shear load resistances

Characteristic Resistances with $c \geq c_{cr}$ and $s \geq s_{cr}$									
Anchor size	Perforated sleeve	Effective Anchorage depth	Use condition						
			d/d			w/d w/w			d/d w/w (w/d)
			40°C/24°C	80°C/50°C	120°C/72°C	40°C/24°C	80°C/50°C	120°C/72°C	All temperature ranges
			h_{ef}	$N_{Rk,b} = N_{Rk,p}^{2)}$			$N_{Rk,b} = N_{Rk,p}^{2)}$		
		[mm]	[kN]						
Normalised mean compressive strength $f_b \geq 28 \text{ N/mm}^2$ 1)									
M8	-	80	7,0	6,5	5,0	6,0	5,5	4,0	7,0
M10 / IG-M6	-	≥ 90							
M12 / IG-M8	-	≥ 100							
M16 / IG-M10	-	≥ 100							
M10 / M12 / M16 / IG-M6 / IG-M8 / IG-M10	-	200							
M8	SH 12	80	7,0	6,5	5,0	6,0	5,5	4,0	
M8 / M10/ IG-M6	SH 16	≥ 85	7,0	6,5	5,0	7,0	6,5	5,0	
M12 / M16 / IG-M8 / IG-M10	SH 20	≥ 85							

1) For lower compressive strengths resistances must be multiplied by the conversion factor according to Table C11. For stones with higher strengths, the shown values are valid without conversion.

2) $N_{Rk,b,c} = N_{Rk,p,c}$ and $V_{Rk,c,II} = V_{Rk,c,I}$ according to Annex C 3

Table C17: Displacements

Anchor size	h_{ef}	$\delta N / N$	δN_0	δN_{∞}	$\delta V / V$	δV_0	δV_{∞}
	[mm]	[mm/kN]	[mm]	[mm]	[mm/kN]	[mm]	[mm]
M8 – M12 / IG-M6 – M10	all	0,1	0,1 * $N_{Rk} / 3,5$	2 * δN_0	0,3	0,3 * $V_{Rk} / 3,5$	1,5 * δV_0
M16	all				0,1	0,1 * $V_{Rk} / 3,5$	1,5 * δV_0

Table C18: Characteristic values of tension and shear load resistances under fire exposure

Anchor size	Perforated sleeve	Effective anchorage depth	Characteristic Resistances			
			$N_{Rk,b,fi} = N_{Rk,p,fi} = V_{Rk,b,fi}$			
			h_{ef}	R30	R60	R90
		[mm]	[kN]			
M8	-	80	0,48	0,41	0,34	0,30
M10 / IG-M6	-	≥ 90				
M12 / IG-M8	-	≥ 100				
M16 / IG-M10	-	≥ 100				
M8	SH 12	80	0,47	0,26	- 1)	- 1)
M8 / M10 / IG-M6	SH 16	≥ 85				
M12 / M16 / IG-M8 / IG-M10	SH 20	≥ 85				

1) no performance assessed

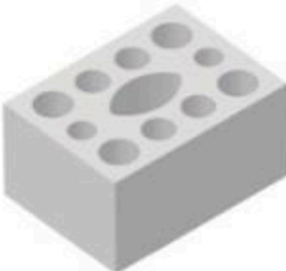
Injection system TILCA TIM V+, TIM V+ Frost for masonry

Performances solid calcium silica brick KS-NF
Characteristic Resistances and Displacements

Annex C 8

Brick type: Hollow Calcium silica brick KSL-3DF

Table C19: Stone description

Brick type	Hollow calcium silica brick KSL-3DF		
Density	ρ [kg/dm ³]	$\geq 1,4$	
Normalised mean compressive strength	f_b [N/mm ²]	≥ 14	
Conversion factor for lower compressive strengths	$(f_b / 14)^{0,75} \leq 1,0$		
Code	EN 771-2:2011+A1:2015		
Producer (Country)	e.g. KS-Wemding (DE)		
Brick dimensions	[mm]	$\geq 240 \times 175 \times 113$	
Drilling method	Rotary drilling		

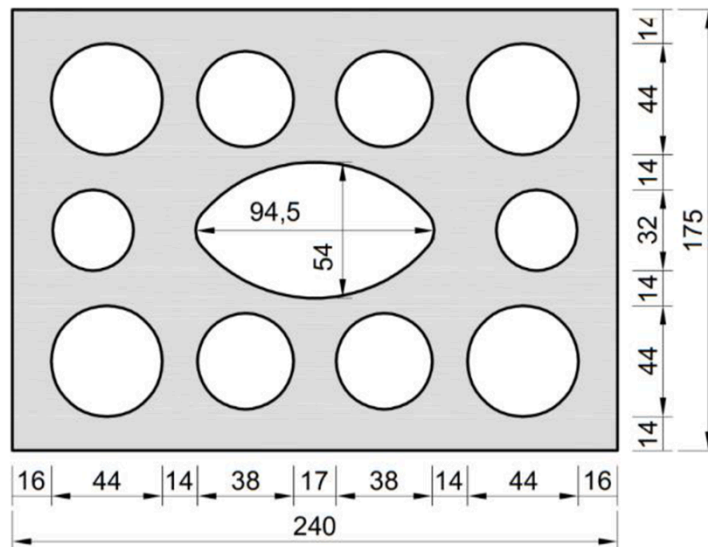
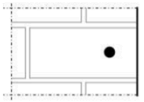
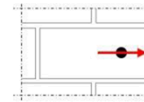
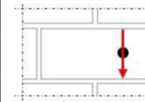


Table C20: Installation parameter

Anchor size		[-]	M8	M10	M12	M16	IG-M6	IG-M8	IG-M10
Installation torque	T_{inst}	[Nm]	≤ 5	≤ 5	≤ 8	≤ 8	≤ 5	≤ 8	≤ 8
Char. Edge distance	c_{cr}	[mm]	120 (for shear loads perpendicular to the free edge: $c_{cr} = 240$)						
Minimum Edge Distance	c_{min}	[mm]	60						
Characteristic Spacing	$s_{cr, II}$	[mm]	240						
	$s_{cr, \perp}$	[mm]	120						
Minimum Spacing	$s_{min, II}; s_{min, \perp}$	[mm]	120						

Table C21: Reduction factors for single anchors at the edge

Tension load			Shear load					
			Perpendicular to the free edge			Parallel to the free edge		
	with $c \geq$	$\alpha_{edge, N}$		with $c \geq$	$\alpha_{edge, V \perp}$		with $c \geq$	$\alpha_{edge, V II}$
	60	1,00		60	0,30		60	1,00
	120	1,00		240	1,00		120	1,00

Injection system TILCA TIM V+, TIM V+ Frost for masonry


Performances hollow calcium silica brick KSL-3DF
Description of the stone, Installation parameters, Reductionfactors

Annex C 9

Brick type: Hollow Calcium silica brick KSL-3DF										
Table C22: Factors for anchor groups under tension load										
Anchor position parallel to hor. joint					Anchor position perpendicular to hor. joint					
	with c ≥	with s ≥	$\alpha_{g II, N}$			with c ≥	with s ≥	$\alpha_{g \perp, N}$		
	60	120	1,50			60	120	1,00		
	120	120	2,00			120	120	2,00		
	120	240	2,00							
Table C23: Factors for anchor groups under shear load										
Anchor position parallel to hor. joint					Anchor position perpendicular to hor. joint					
Shear load perpendicular to the free edge		with c ≥	with s ≥	$\alpha_{g II, V \perp}$			with c ≥	with s ≥	$\alpha_{g \perp, V \perp}$	
		60	120	0,30			60	120	0,30	
		120	120	1,00			240	120	2,00	
		120	240	2,00						
Shear load parallel to the free edge		with c ≥	with s ≥	$\alpha_{g II, V \parallel}$			with c ≥	with s ≥	$\alpha_{g \perp, V \parallel}$	
		60	120	1,00			60	120	1,00	
		120	120	1,60			120	120	2,00	
		120	240	2,00						
Table C24: Characteristic values of tension and shear load resistances										
Anchor size	Perforated sleeve	Effective Anchorage depth	Characteristic Resistances with $c \geq c_{cr}$ and $s \geq s_{cr}$							All temperature ranges
			Use condition							
			d/d			w/d			d/d	
			40°C/24°C	80°C/50°C	120°C/72°C	40°C/24°C	80°C/50°C	120°C/72°C	w/d	
			h _{ef}			N _{rk,b} = N _{rk,p} ²⁾			N _{rk,b} = N _{rk,p} ²⁾	
[mm]			[kN]							
Normalised mean compressive strength $f_b \geq 14 \text{ N/mm}^2$ 1)										
M8 / M10 / IG-M6	SH 16	≥ 85	2,5	2,5	1,5	2,5	2,5	1,5	6,0	
		130	2,5	2,5	2,0	2,5	2,5	2,0	6,0	
M12 / M16 / IG-M8 / IG-M10	SH 20	≥ 85	6,5	6,0	4,5	6,5	6,0	4,5	6,0	
1) For lower compressive strengths resistances must be multiplied by the conversion factor according to Table C19. For stones with higher strengths, the shown values are valid without conversion.										
2) $N_{rk,b,c} = N_{rk,p,c}$ and $V_{rk,c \perp} = V_{rk,c \perp}$ according to Annex C 3										
Table C25: Displacements										
Anchor size	h _{ef}	δ_N / N	δ_{N0}	$\delta_{N\infty}$	δ_V / V	δ_{V0}	$\delta_{V\infty}$			
	[mm]	[mm/kN]	[mm]	[mm]	[mm/kN]	[mm]	[mm]			
M8 – M12 / IG-M6 – M10	all	0,13	0,13*N _{rk} / 3,5	2* δ_{N0}	0,55	0,55*V _{rk} / 3,5	1,5* δ_{V0}			
	M16				all	0,31	0,31*V _{rk} / 3,5	1,5* δ_{V0}		
Injection system TILCA TIM V+, TIM V+ Frost for masonry							Annex C 10			
Performances hollow calcium silica brick KSL-3DF Group factors, characteristic Resistances and Displacements										

Brick type: Hollow Calcium silica brick KSL-8DF

Table C26: Stone description

Brick type	Hollow Calcium silica brick KSL-8DF		
Density	ρ [kg/dm ³]	$\geq 1,4$	
Normalised mean compressive strength	f_b [N/mm ²]	≥ 12	
Conversion factor for lower compressive strengths	$(f_b / 12)^{0,75} \leq 1,0$		
Code	EN 771-2:2011+A1:2015		
Producer (Country)	e.g. KS-Wemding (DE)		
Brick dimensions	[mm]	$\geq 248 \times 240 \times 238$	
Drilling method	Rotary drilling		

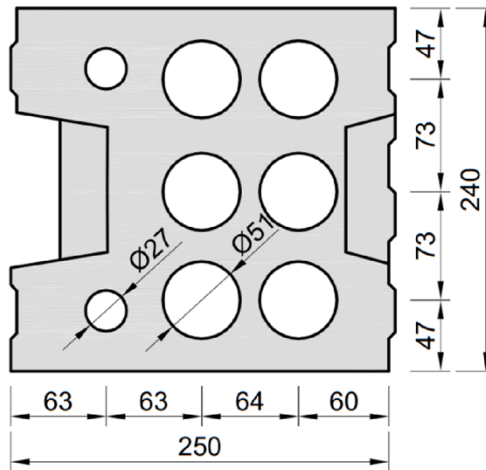
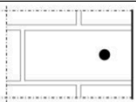
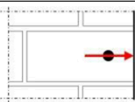
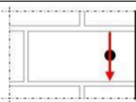


Table C27: Installation parameter

Anchor size		[-]	M8	M10	M12	M16	IG-M6	IG-M8	IG-M10
Installation torque	T_{inst}	[Nm]	≤ 5	≤ 5	≤ 8	≤ 8	≤ 5	≤ 8	≤ 8
Char. Edge distance	c_{cr}	[mm]	120 (for shear loads perpendicular to the free edge: $c_{cr} = 250$)						
Minimum Edge Distance	c_{min}	[mm]	50						
Characteristic Spacing	$s_{cr, II}$	[mm]	250						
	$s_{cr, \perp}$	[mm]	120						
Minimum Spacing	$s_{min, II}; s_{min, \perp}$	[mm]	50						

Table C28: Reduction factors for single anchors at the edge

Tension load			Shear load					
			Perpendicular to the free edge			Parallel to the free edge		
	with $c \geq$	$\alpha_{edge, N}$		with $c \geq$	$\alpha_{edge, V \perp}$		with $c \geq$	$\alpha_{edge, V II}$
	50	1,00		50	0,30		50	1,00
	120	1,00		250	1,00		120	1,00

Injection system TILCA TIM V+, TIM V+ Frost for masonry

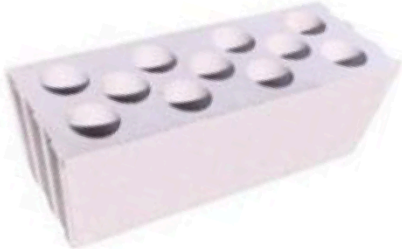
Performances hollow calcium silica brick KSL-8DF
Description of the stone, Installation parameters, Reductionfactors

Annex C 11

Brick type: Hollow Calcium silica brick KSL-8DF										
Table C29: Factors for anchor groups under tension load										
Anchor position parallel to hor. joint					Anchor position perpendicular to hor. joint					
	with $c \geq$	with $s \geq$	$\alpha_{g II, N}$			with $c \geq$	with $s \geq$	$\alpha_{g \perp, N}$		
	50	50	1,00			50	50	1,00		
	120	250	2,00			120	120	2,00		
Table C30: Factors for anchor groups under shear load										
Anchor position parallel to hor. joint					Anchor position perpendicular to hor. joint					
Shear load perpendicular to the free edge		with $c \geq$	with $s \geq$	$\alpha_{g II, V \perp}$			with $c \geq$	with $s \geq$	$\alpha_{g \perp, V \perp}$	
		50	50	0,45			50	50	0,45	
		250	50	1,15			250	50	1,20	
Shear load parallel to the free edge		with $c \geq$	with $s \geq$	$\alpha_{g II, V II}$			with $c \geq$	with $s \geq$	$\alpha_{g \perp, V II}$	
		50	50	1,30			50	50	1,00	
		120	250	2,00			120	250	2,00	
Table C31: Characteristic values of tension and shear load resistances										
Anchor size	Perforated sleeve	Effective Anchorage depth	Characteristic Resistances with $c \geq c_{cr}$ and $s \geq s_{cr}$							
			Use condition							
			d/d			w/d			d/d	
			w/w			w/w			w/w	
			40°C/24°C	80°C/50°C	120°C/72°C	40°C/24°C	80°C/50°C	120°C/72°C	All Temperature ranges	
h_{ef}	$N_{Rk,b} = N_{Rk,p}^{2)}$			$N_{Rk,b} = N_{Rk,p}^{2)}$			$V_{Rk,b}^{2)}$			
[mm]	[kN]									
Normalised mean compressive strength $f_b \geq 12 \text{ N/mm}^2$ 1)										
M8 / M10 / IG-M6	SH 16	130	5,0	4,5	3,5	5,0	4,5	3,5	3,5	
M12 / M16 / IG-M8 / IG-M10	SH 20	≥ 130	5,0	4,5	3,5	5,0	4,5	3,5	6,0	
1) For lower compressive strengths resistances must be multiplied by the conversion factor according to Table C26. For stones with higher strengths, the shown values are valid without conversion.										
2) $N_{Rk,b,c} = N_{Rk,p,c}$ and $V_{Rk,c II} = V_{Rk,c \perp}$ according to Annex C 3										
Table C32: Displacements										
Anchor size	h_{ef}	$\delta N / N$	δN_0	δN_{∞}	$\delta V / V$	δV_0	δV_{∞}			
	[mm]	[mm/kN]	[mm]	[mm]	[mm/kN]	[mm]	[mm]			
M8 – M12 / IG-M6 – M10	all	0,13	0,13* $N_{Rk} / 3,5$	2* δN_0	0,55	0,55* $V_{Rk} / 3,5$	1,5* δV_0			
M16	all				0,31	0,31* $V_{Rk} / 3,5$	1,5* δV_0			
Injection system TILCA TIM V+, TIM V+ Frost for masonry							Annex C 12			
Performances hollow calcium silica brick KSL-8DF Group factors, characteristic Resistances and Displacements										

Brick type: Hollow Calcium silica brick KSL-12DF

Table C33: Stone description

Brick type	Hollow Calcium silica brick KSL-12DF		
Density ρ [kg/dm ³]	$\geq 1,4$		
Normalised mean compressive strength f_b [N/mm ²]	≥ 12		
Conversion factor for lower compressive strengths	$(f_b / 12)^{0,75} \leq 1,0$		
Code	EN 771-2:2011+A1:2015		
Producer (Country)	e.g. KS-Wemding (DE)		
Brick dimensions [mm]	$\geq 498 \times 175 \times 238$		
Drilling method	Rotary drilling		

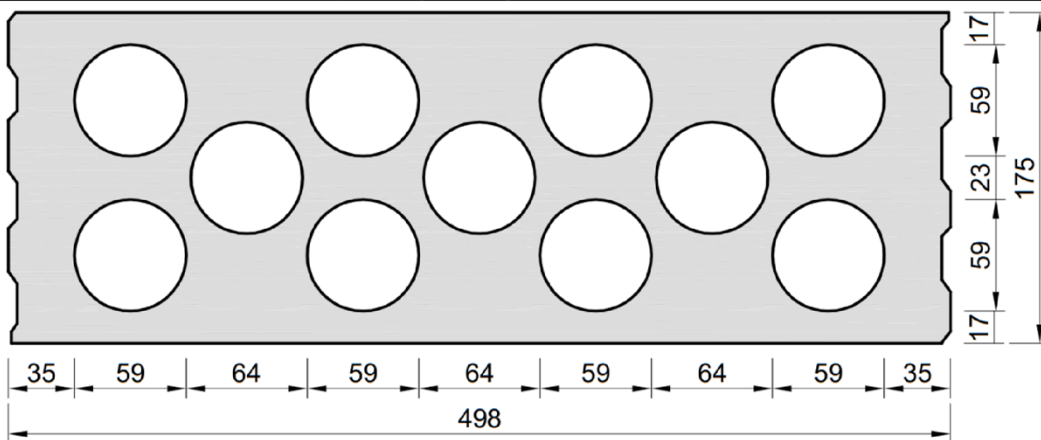


Table C34: Installation parameter

Anchor size		[-]	M8	M10	M12	M16	IG-M6	IG-M8	IG-M10
Installation torque	T_{inst}	[Nm]	≤ 4	≤ 4	≤ 5	≤ 5	≤ 4	≤ 5	≤ 5
Char. Edge distance (under fire conditions)	$c_{cr}, (c_{cr,fi})$	[mm]	120 (2 h_{ef}) (for shear loads perpendicular to the free edge: $c_{cr} = 500$)						
Minimum Edge Distance	c_{min}	[mm]	50						
Characteristic Spacing (under fire conditions)	$s_{cr, II}; (s_{cr,fi, II})$	[mm]	500 (4 h_{ef})						
	$s_{cr, \perp}; (s_{cr,fi, \perp})$	[mm]	120 (4 h_{ef})						
Minimum Spacing	$s_{min, II}; s_{min, \perp}$	[mm]	50						

Table C35: Reduction factors for single anchors at the edge

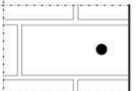


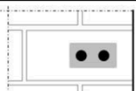
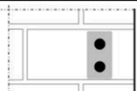
Tension load	Shear load							
	Perpendicular to the free edge			Parallel to the free edge				
	with $c \geq$	$\alpha_{edge, N}$	with $c \geq$	$\alpha_{edge, V \perp}$	with $c \geq$	$\alpha_{edge, V \parallel}$		
	50	1,00		50	0,45		50	1,00
	120	1,00		500	1,00		120	1,00

Table C36: Factors for anchor groups under tension load

Anchor position parallel to hor. joint				Anchor position perpendicular to hor. joint			
	with $c \geq$	with $s \geq$	$\alpha_{g II, N}$		with $c \geq$	with $s \geq$	$\alpha_{g \perp, N}$
	50	50	1,50		50	50	1,00
	120	500	2,00		120	240	2,00

Injection system TILCA TIM V+, TIM V+ Frost for masonry

Performances hollow calcium silica brick KSL-12DF
Description of the stone, Installation parameters, Reductionfactors

Annex C 13

Brick type: Hollow Calcium silica brick KSL-12DF										
Table C37: Factors for anchor groups under shear load										
		Anchor position parallel to hor. joint				Anchor position perpendicular to hor. joint				
Shear load perpendicular to the free edge		with $c \geq$	with $s \geq$	$\alpha_{g II, V \perp}$			with $c \geq$	with $s \geq$	$\alpha_{g \perp, V \perp}$	
		50	50	0,55			50	50	0,50	
		500	50	1,00			500	50	1,00	
Shear load parallel to the free edge		with $c \geq$	with $s \geq$	$\alpha_{g II, V \parallel}$			with $c \geq$	with $s \geq$	$\alpha_{g \perp, V \parallel}$	
		50	50	2,00			50	50	1,30	
		120	500	2,00			120	250	2,00	

Table C38: Characteristic values of tension and shear load resistances									
Anchor size	Perforated sleeve	Effective Anchorage depth	Characteristic Resistances with $c \geq c_{cr}$ and $s \geq s_{cr}$						
			Use condition						
			d/d			w/d w/w			d/d w/w (w/d)
			40°C/24°C	80°C/50°C	120°C/72°C	40°C/24°C	80°C/50°C	120°C/72°C	All temperature ranges
h_{ef}	$N_{Rk,b} = N_{Rk,p}^{2)}$			$N_{Rk,b} = N_{Rk,p}^{2)}$			$V_{Rk,b}^{2)}$		
[mm]	[kN]								
Normalised mean compressive strength $f_b \geq 12 \text{ N/mm}^2$ 1)									
M8 / M10 / IG-M6	SH 16	130	3,5	3,5	2,5	3,5	3,5	2,5	3,5
M12 / M16 / IG-M8 / IG-M10	SH 20	≥ 130	3,5	3,5	2,5	3,5	3,5	2,5	7,0

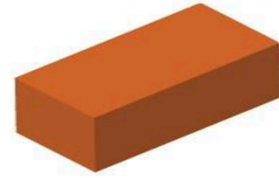
1) For lower compressive strengths resistances must be multiplied by the conversion factor according to Table C33. For stones with higher strengths, the shown values are valid without conversion.
2) $N_{Rk,b,c} = N_{Rk,p,c}$ and $V_{Rk,c,II} = V_{Rk,c \perp}$ according to Annex C 3

Table C39: Displacements							
Anchor size	h_{ef}	$\delta N / N$	δN_0	δN_{∞}	$\delta V / V$	δV_0	δV_{∞}
	[mm]	[mm/kN]	[mm]	[mm]	[mm/kN]	[mm]	[mm]
M8 – M12 / IG-M6 – M10	all	0,13	0,13 * $N_{Rk} / 3,5$	2 * δN_0	0,55	0,55 * $V_{Rk} / 3,5$	1,5 * δV_0
M16	all				0,31	0,31 * $V_{Rk} / 3,5$	1,5 * δV_0

Table C40: Characteristic values of tension and shear load resistances under fire exposure							
Anchor size	Perforated sleeve	Effective anchorage depth	Characteristic Resistances				
			$N_{Rk,b,fi} = N_{Rk,p,fi} = V_{Rk,b,fi}$				
			h_{ef}	R30	R60	R90	R120
		[mm]	[kN]				
M8 / M10 / IG-M6	SH 16	130	0,37	0,27	0,17	-1)	
M12 / IG-M8	SH 20	≥ 130					
M16 / IG-M10	SH 20	≥ 130					0,12

1) no performance assessed

Injection system TILCA TIM V+, TIM V+ Frost for masonry	Annex C 14
Performances hollow calcium silica brick KSL-12DF Group factors, characteristic Resistances and Displacements	



Brick type: Solid clay brick 1DF

Table C41: Stone description

Brick type	Solid clay brick Mz-1DF	
Density ρ [kg/dm ³]	$\geq 2,0$	
Normalised mean compressive strength f_b [N/mm ²]	≥ 20	
Conversion factor for lower compressive strengths	$(f_b / 20)^{0,5} \leq 1,0$	
Code	EN 771-1:2011+A1:2015	
Producer (Country)	e.g. Wienerberger (DE)	
Brick dimensions [mm]	$\geq 240 \times 115 \times 55$	
Drilling method	Hammer drilling	

Table C42: Installation parameter

Anchor size		[-]	M8	M10	M12	M16	IG-M6	IG-M8	IG-M10
Installation torque	T_{inst}	[Nm]	≤ 10	≤ 10	≤ 10	≤ 10	≤ 10	≤ 10	≤ 10
Char. Edge distance	c_{cr}	[mm]	150 (for shear loads perpendicular to the free edge: $c_{cr} = 240$)						
Minimum Edge Distance	c_{min}	[mm]	60						
Characteristic Spacing	$s_{cr, II}$	[mm]	240						
	$s_{cr, \perp}$	[mm]	130						
Minimum Spacing	$s_{min, II}; s_{min, \perp}$	[mm]	65						

Table C43: Reduction factors for single anchors at the edge

Tension load			Shear load					
			Perpendicular to the free edge			Parallel to the free edge		
	with $c \geq$	$\alpha_{edge, N}$		with $c \geq$	$\alpha_{edge, V \perp}$		with $c \geq$	$\alpha_{edge, V II}$
	60	0,75		60	0,10		60	0,30
	150	1,00		100	0,50		100	0,65
	180	1,00		240	1,00		150	1,00

Table C44: Factors for anchor groups under tension load

Anchor position parallel to hor. joint				Anchor position perpendicular to hor. joint			
	with $c \geq$	with $s \geq$	$\alpha_{g II, N}$		with $c \geq$	with $s \geq$	$\alpha_{g \perp, N}$
	60	65	0,85		60	65	1,00
	150	65	1,15		150	65	1,20
	150	240	2,00		150	130	2,00

Table C45: Factors for anchor groups under shear load

	Anchor position parallel to hor. joint				Anchor position perpendicular to hor. joint			
		with $c \geq$	with $s \geq$	$\alpha_{g II, V \perp}$		with $c \geq$	with $s \geq$	$\alpha_{g \perp, V \perp}$
Shear load perpendicular to the free edge		60	65	0,40		60	65	0,30
		240	65	2,00		240	65	2,00
		240	240	2,00		240	130	2,00
Shear load parallel to the free edge		60	65	1,75		60	65	1,10
		150	65	2,00		150	65	2,00
		150	240	2,00		150	130	2,00

Injection system TILCA TIM V+, TIM V+ Frost for masonry

Performances solid clay brick 1DF

Description of the stone, Installation parameters, Reduction- and Group factors

Annex C 15

Brick type: Solid clay brick 1DF

Table C46: Characteristic values of tension and shear load resistances

Anchor size	Perforated sleeve	Effective Anchorage depth	Characteristic Resistances with $c \geq c_{cr}$ and $s \geq s_{cr}$						
			Use condition						
			d/d			w/d w/w			d/d w/d w/w
			40°C/24°C	80°C/50°C	120°C/72°C	40°C/24°C	80°C/50°C	120°C/72°C	All temperature ranges
			h_{ef}	$N_{Rk,b} = N_{Rk,p}^{2)}$			$N_{Rk,b} = N_{Rk,p}^{2)}$		
[mm]	[kN]								
Normalised mean compressive strength $f_b \geq 20 \text{ N/mm}^2$ 1)									
M8	-	80							
M10 / IG-M6	-	≥ 90	7,0	6,0	6,0	7,0	6,0	6,0	8,0
M12 / IG-M8	-	≥ 100							
M16 / IG-M10	-	≥ 100	8,0	6,5	6,5	8,0	6,5	6,5	12,0
M8	SH 12	80							
M8 / M10/ IG-M6	SH 16	≥ 85	7,0	6,0	6,0	7,0	6,0	6,0	8,0
M12 / IG-M8	SH 20								
M16 / IG-M10	SH 20	≥ 85	8,0	6,5	6,5	8,0	6,5	6,5	12,0

1) For lower compressive strengths resistances must be multiplied by the conversion factor according to Table C41. For stones with higher strengths, the shown values are valid without conversion.

2) $N_{Rk,b,c} = N_{Rk,p,c}$ and $V_{Rk,c II} = V_{Rk,c I}$ according to Annex C 3

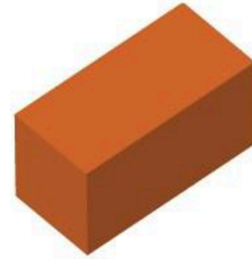
Table C47: Displacements

Anchor size	h_{ef} [mm]	δ_N / N [mm/kN]	δ_{N0} [mm]	$\delta_{N\infty}$ [mm]	δ_V / V [mm/kN]	δ_{V0} [mm]	$\delta_{V\infty}$ [mm]
M8 – M12 / IG-M6 – M10	all	0,1	0,1 * $N_{Rk} / 3,5$	2 * δ_{N0}	0,3	0,3 * $V_{Rk} / 3,5$	1,5 * δ_{V0}
M16	all				0,1	0,1 * $V_{Rk} / 3,5$	1,5 * δ_{V0}

Injection system TILCA TIM V+, TIM V+ Frost for masonry

Performances solid clay brick 1DF
Characteristic Resistances and Displacements

Annex C 16



Brick type: Solid clay brick 2DF

Table C48: Stone description

Brick type	Solid clay brick Mz- 2DF
Density ρ [kg/dm ³]	$\geq 2,0$
Normalised mean compressive strenght f_b [N/mm ²]	≥ 28
Conversion factor for lower compressive strengths	$(f_b / 28)^{0,5} \leq 1,0$
Code	EN 771-1:2011+A1:2015
Producer (Country)	e.g. Wienerberger (DE)
Brick dimensions [mm]	$\geq 240 \times 115 \times 113$
Drilling method	Hammer drilling

Table C49: Installation parameter

Anchor size		[-]	M8	M10	M12	M16	IG-M6	IG-M8	IG-M10
Installation torque	T_{inst}	[Nm]	≤ 10	≤ 10	≤ 10	≤ 10	≤ 10	≤ 10	≤ 10
Char. Edge distance (under fire conditions)	$c_{cr}, (c_{cr,fi})$	[mm]	150 (2 h_{ef}) (for shear loads perpendicular to the free edge: $c_{cr} = 240$)						
Minimum Edge Distance	c_{min}	[mm]	50						
Characteristic Spacing (under fire conditions)	$s_{cr, II}, (s_{cr,fi, II})$	[mm]	240 (4 h_{ef})						
	$s_{cr, \perp}, (s_{cr,fi, \perp})$	[mm]	240 (4 h_{ef})						
Minimum Spacing	$s_{min, II}, s_{min, \perp}$	[mm]	50						

Table C50: Reduction factors for single anchors at the edge

Tension load			Shear load perpendicular to free edge			Shear load parallel to free edge		
	with $c \geq$	$\alpha_{edge, N}$		with $c \geq$	$\alpha_{edge, V \perp}$		with $c \geq$	$\alpha_{edge, V II}$
	50 ¹⁾	1,00		50	0,20		50	1,00
	150 ¹⁾	1,00		125	0,50		150	1,00
	180	1,00		240	1,00			

1) All applications, except for $h_{ef} = 200\text{mm}$ and without sleeve

Table C51: Factors for anchor groups under tension load

Anchor position parallel to hor. joint				Anchor position perpendicular to hor. joint			
	with $c \geq$	with $s \geq$	$\alpha_{g II, N}$		with $c \geq$	with $s \geq$	$\alpha_{g \perp, N}$
	50 ¹⁾	50	1,50		50 ¹⁾	50	0,80
	150 ¹⁾	240	2,00		150 ¹⁾	240	2,00
	180 ²⁾	60	1,00		180 ²⁾	60	1,00
	180 ²⁾	240	1,55				
	240 ²⁾	240	2,00		180 ²⁾	120	2,00

1) All applications, except for $h_{ef} = 200\text{mm}$ and without sleeve

2) Only for application with $h_{ef} = 200\text{mm}$ and without sleeve

Table C52: Factors for anchor groups under shear load

	Anchor position parallel to hor. joint				Anchor position perpendicular to hor. joint			
		with $c \geq$	with $s \geq$	$\alpha_{g II, V \perp}$		with $c \geq$	with $s \geq$	$\alpha_{g \perp, V \perp}$
Shear load perpendicular to the free edge		50	50	0,40		50	50	0,20
		240	50	1,20		240	50	0,60
		240	240	2,00		240	125	1,00
						240	240	2,00
Shear load parallel to the free edge		50	50	1,20		50	50	1,00
		150	240	2,00		50	125	1,00
						150	240	2,00

Injection system TILCA TIM V+, TIM V+ Frost for masonry

Performances solid clay brick 2DF


Description of the stone, Installation parameters, Reduction- and Group factors

Annex C 17

Brick type: Solid clay brick 2DF									
Table C53: Characteristic values of tension and shear load resistances									
Anchor size	Perforated sleeve	Effective Anchorage depth	Characteristic Resistances with $c \geq c_{cr}$ and $s \geq s_{cr}$						
			Use condition						
			d/d			w/d w/w			d/d w/d w/w
			40°C/24°C	80°C/50°C	120°C/72°C	40°C/24°C	80°C/50°C	120°C/72°C	All temperature ranges
			h_{ef}	$N_{Rk,b} = N_{Rk,p}^{2)}$			$N_{Rk,b} = N_{Rk,p}^{2)}$		
[mm]	[kN]								
Normalised mean compressive strength $f_b \geq 28 \text{ N/mm}^2$ 1)									
M8	-	80							
M10 / IG-M6	-	≥ 90	9,0	9,0	7,5	9,0	9,0	7,5	9,5
M12 / IG-M8	-	≥ 100	9,0	9,0	7,5	9,0	9,0	7,5	12
M16 / IG-M10	-	≥ 100	9,0	9,0	7,5	9,0	9,0	7,5	12 ³⁾
M10 / M12 / IG-M6 / IG-M8	-	200	11,5	11,5	10,0	6,0	6,0	5,0	8,0
M16 / IG-M10	-	200	11,5	11,5	10,0	6,0	6,0	5,0	12,0
M8	SH 12	80							
M8 / M10 / IG-M6	SH 16	≥ 85	9,0	9,0	7,5	9,0	9,0	7,5	9,5
M12 / IG-M8	SH 20	≥ 85	9,0	9,0	7,5	9,0	9,0	7,5	12,0
M16 / IG-M10	SH 20	≥ 85	9,0	9,0	7,5	9,0	9,0	7,5	12,0 ³⁾
1) For lower compressive strengths resistances must be multiplied by the conversion factor according to Table C48. For stones with higher strengths, the shown values are valid without conversion.									
2) $N_{Rk,b,c} = N_{Rk,p,c}$ and $V_{Rk,c,II} = V_{Rk,c,I}$ according to Annex C 3									
3) Valid for all stone strengths with min. 10 N/mm ²									
Table C54: Displacements									
Anchor size	h_{ef}	$\delta N / N$	δN_0	δN_∞	$\delta V / V$	δV_0	δV_∞		
	[mm]	[mm/kN]	[mm]	[mm]	[mm/kN]	[mm]	[mm]		
M8 – M12 / IG-M6 – M10	all	0,1	0,1 * $N_{Rk} / 3,5$	2 * δN_0	0,3	0,3 * $V_{Rk} / 3,5$	1,5 * δV_0		
M16	all				0,1	0,1 * $V_{Rk} / 3,5$	1,5 * δV_0		
Table C55: Characteristic values of tension and shear load resistances under fire exposure									
Anchor size	Perforated sleeve	Effective Anchorage depth	Characteristic Resistances						
			$N_{Rk,b,fi} = N_{Rk,p,fi} = V_{Rk,b,fi}$						
		h_{ef}	R30	R60	R90	R120			
		[mm]	[kN]						
M8	-	80							
M10 / IG-M6	-	≥ 90	0,51	0,44	0,36	0,33			
M12 / IG-M8	-	≥ 100							
M16 / IG-M10	-	≥ 100							
M8	SH 12	80	0,36	0,26	0,15	0,10			
M8 / M10 / IG-M6	SH 16	≥ 85	0,36	0,26	0,15	0,10			
		130	0,92	0,74	0,57	0,49			
M12 / M16 / IG-M8 / IG-M10	SH 20	≥ 85	0,36	0,26	0,15	0,10			
		≥ 130	0,92	0,74	0,57	0,49			
Injection system TILCA TIM V+, TIM V+ Frost for masonry						Annex C 18			
Performances solid clay brick 2DF Characteristic Resistances and Displacements									

Brick type: Hollow clay brick 10 DF

Table C56: Stone description

Brick type	Hollow clay brick HLZ-10DF		
Density	ρ [kg/dm ³]	$\geq 1,25$	
Normalised mean compressive strength	f_b [N/mm ²]	≥ 20	
Conversion factor for lower compressive strengths	$(f_b / 20)^{0,5} \leq 1,0$		
Code	EN 771-1:2011+A1:2015		
Producer (Country)	e.g. Wienerberger (DE)		
Brick dimensions	[mm]	300 x 240 x 249	
Drilling method	Rotary drilling		

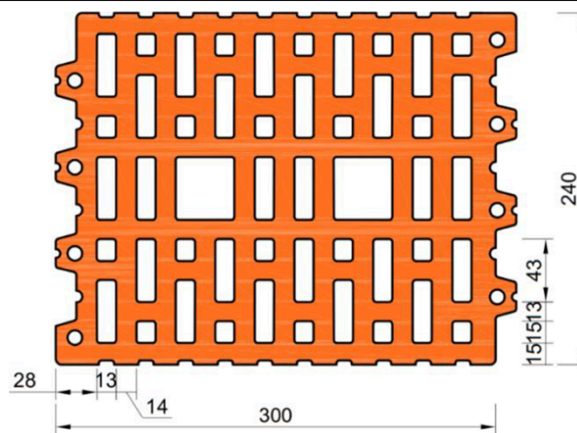


Table C57: Installation parameter

Anchor size		[-]	M8	M10	M12	M16	IG-M6	IG-M8	IG-M10
Installation torque	T_{inst}	[Nm]	≤ 5	≤ 10	≤ 10	≤ 10	≤ 5	≤ 5	≤ 10
Char. Edge distance (under fire conditions)	$c_{cr}, (c_{cr,fi})$	[mm]	120 (2 h_{ef}) (for shear loads perpendicular to the free edge: $c_{cr} = 300$)						
Minimum Edge Distance	c_{min}	[mm]	50						
Characteristic Spacing (under fire conditions)	$s_{cr, II}, (s_{cr,fi, II})$	[mm]	300 (4 h_{ef})						
	$s_{cr, \perp}, (s_{cr,fi, \perp})$	[mm]	250 (4 h_{ef})						
Minimum Spacing	$s_{min, II}, s_{min, \perp}$	[mm]	50						

Table C58: Reduction factors for single anchors at the edge

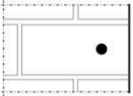
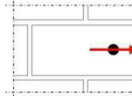
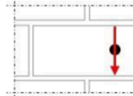
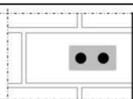
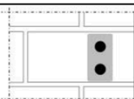
Tension load			Shear load					
			Perpendicular to the free edge			Parallel to the free edge		
	with $c \geq$	$\alpha_{edge, N}$		with $c \geq$	$\alpha_{edge, V \perp}$		with $c \geq$	$\alpha_{edge, V II}$
	50	1,00		50	0,20		50	1,00
	120	1,00		300	1,00		120	1,00

Table C59: Factors for anchor groups under tension load

Anchor position parallel to hor. joint				Anchor position perpendicular to hor. joint			
	with $c \geq$	with $s \geq$	$\alpha_{g II, N}$		with $c \geq$	with $s \geq$	$\alpha_{g \perp, N}$
	50	50	1,55		50	50	1,00
	120	300	2,00		120	250	2,00

Injection system TILCA TIM V+, TIM V+ Frost for masonry

Performances hollow clay brick HLZ 10DF

Description of the stone, Installation parameters, Reductionfactors

Annex C 19

Brick type: Hollow clay brick 10 DF									
Table C60: Factors for anchor groups under shear load									
		Anchor position parallel to hor. joint			Anchor position perpendicular to hor. joint				
Shear load perpendicular to the free edge		with c ≥	with s ≥	$\alpha_{g II, V \perp}$		with c ≥	with s ≥	$\alpha_{g \perp, V \perp}$	
		50	50	0,30		50	50	0,20	
		300	50	1,40		300	50	1,00	
Shear load parallel to the free edge		with c ≥	with s ≥	$\alpha_{g II, V \parallel}$		with c ≥	with s ≥	$\alpha_{g \perp, V \parallel}$	
		50	50	1,85		50	50	1,00	
		120	300	2,00		120	250	2,00	
Table C61: Characteristic values of tension and shear load resistances									
Anchor size	Perforated sleeve	Effective Anchorage depth	Characteristic Resistances with $c \geq c_{cr}$ and $s \geq s_{cr}$						
			Use condition						
			d/d			w/d w/w			d/d w/d w/w
			40°C/24°C	80°C/50°C	120°C/72°C	40°C/24°C	80°C/50°C	120°C/72°C	All temperature ranges
			h_{ef}	$N_{Rk,b} = N_{Rk,p}^{2)}$			$N_{Rk,b} = N_{Rk,p}^{2)}$		
[mm]	[kN]								
Normalised mean compressive strength $f_b \geq 20 \text{ N/mm}^2$ 1)									
M8	SH 12	80							
M8 / M10/ IG-M6	SH 16	≥ 85	2,5	2,5	2,0	2,5	2,5	2,0	8,0
M12 / IG-M8	SH 20	≥ 85	5,0	5,0	4,5	5,0	5,0	4,5	8,0
M16 / IG-M10	SH 20	≥ 85	5,0	5,0	4,5	5,0	5,0	4,5	11,5
1) For lower compressive strengths resistances must be multiplied by the conversion factor according to Table C56. For stones with higher strengths, the shown values are valid without conversion.									
2) $N_{Rk,b,c} = N_{Rk,p,c}$ and $V_{Rk,c \parallel} = V_{Rk,c \perp}$ according to Annex C 3									
Table C62: Displacements									
Anchor size	h_{ef}	$\delta N / N$	δN_0	δN_{∞}	$\delta V / V$	δV_0	δV_{∞}		
	[mm]	[mm/kN]	[mm]	[mm]	[mm/kN]	[mm]	[mm]		
M8 – M12 / IG-M6 – M10	all	0,13	$0,13 \cdot N_{Rk} / 3,5$	$2 \cdot \delta N_0$	0,55	$0,55 \cdot V_{Rk} / 3,5$	$1,5 \cdot \delta V_0$		
M16	all				0,31	$0,31 \cdot V_{Rk} / 3,5$	$1,5 \cdot \delta V_0$		
Table C63: Characteristic values of tension and shear load resistances under fire exposure									
Anchor size	Perforated sleeve	Effective Anchorage depth	Characteristic Resistances						
		h_{ef}	R30	R60	R90	R120			
		[mm]	[kN]						
M8 / M10 / IG-M6	SH 16	130							
M12 / M16 / IG-M8 IG-M10	SH 20	≥ 130	0,57	0,39	0,21	0,12			
Injection system TILCA TIM V+, TIM V+ Frost for masonry							Annex C 20		
Performances hollow clay brick HLZ 10DF Group factors, characteristic Resistances and Displacements									

Brick type: Hollow Clay brick Porotherm Homebric

Table C64: Stone description

Brick type	Hollow clay brick Porotherm Homebric	
Density	ρ [kg/dm ³]	$\geq 0,70$
Normalised mean compressive strength	f_b [N/mm ²]	≥ 10
Conversion factor for lower compressive strengths	$(f_b / 10)^{0,5} \leq 1,0$	
Code	EN 771-1:2011+A1:2015	
Producer (Country)	e.g. Wienerberger (FR)	
Brick dimensions	[mm]	500 x 200 x 300
Drilling method	Rotary drilling	

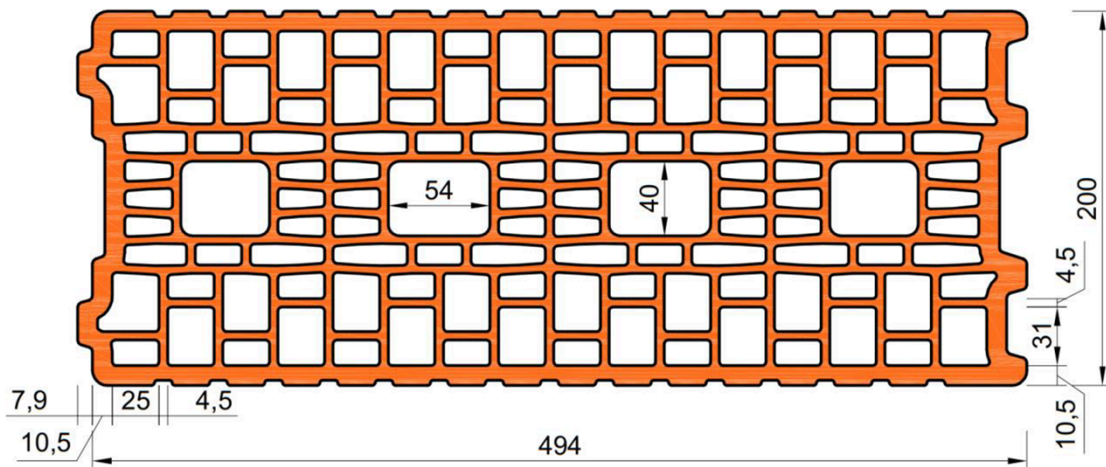
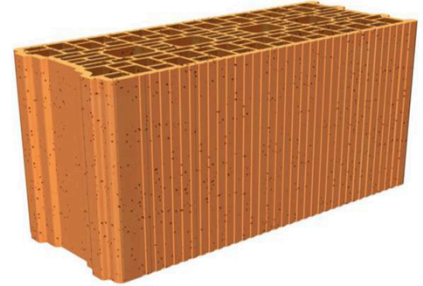


Table C65: Installation parameter

Anchor size		[-]	M8	M10	M12	M16	IG-M6	IG-M8	IG-M10
Installation torque	T_{inst}	[Nm]	≤ 2	≤ 2	≤ 2	≤ 2	≤ 2	≤ 2	≤ 2
Char. Edge distance	c_{cr}	[mm]	120 (for shear loads perpendicular to the free edge: $c_{cr} = 500$)						
Minimum Edge Distance	c_{min}	[mm]	120						
Characteristic Spacing	$s_{cr, II}$	[mm]	500						
	$s_{cr, \perp}$	[mm]	300						
Minimum Spacing	$s_{min, II}$ $s_{min, \perp}$	[mm]	120						

Table C66: Reduction factors for single anchors at the edge

Tension load			Shear load					
			Perpendicular to the free edge			Parallel to the free edge		
	with $c \geq$	$\alpha_{edge, N}$		with $c \geq$	$\alpha_{edge, V \perp}$		with $c \geq$	$\alpha_{edge, V II}$
	120	1,00		120	0,30		120	0,60
	120	1,00		250	0,60		200	1,00
	120	1,00		500	1,00			

Injection system TILCA TIM V+, TIM V+ Frost for masonry

Performances hollow clay brick Porotherm Homebric
Description of the stone, Installation parameters, Reductionfactors

Annex C 21

Brick type: Hollow Clay brick Porotherm Homebric

Table C67: Factors for anchor groups under tension load

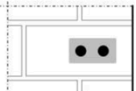
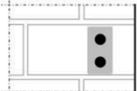
Anchor position parallel to hor. joint				Anchor position perpendicular to hor. joint			
	with $c \geq$	with $s \geq$	$\alpha_{g II, N}$		with $c \geq$	with $s \geq$	$\alpha_{g \perp, N}$
	120	100	1,00		120	100	1,00
	200	100	2,00		200	100	1,20
	120	500	2,00		120	300	2,00

Table C68: Factors for anchor groups under shear load

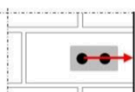
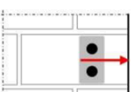
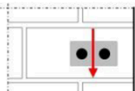

Anchor position parallel to hor. joint				Anchor position perpendicular to hor. joint				
Shear load perpendicular to the free edge		with $c \geq$	with $s \geq$	$\alpha_{g II, V \perp}$		with $c \geq$	with $s \geq$	$\alpha_{g \perp, V \perp}$
		120	100	0,30		120	100	0,30
		250	100	0,60		250	100	0,60
		500	100	1,00		120	300	2,00
Shear load parallel to the free edge		with $c \geq$	with $s \geq$	$\alpha_{g II, V \parallel}$		with $c \geq$	with $s \geq$	$\alpha_{g \perp, V \parallel}$
		120	100	1,00		120	100	1,00
		120	500	2,00		120	300	2,00

Table C69: Characteristic values of tension and shear load resistances

Anchor size	Perforated sleeve	Effective Anchorage depth	Characteristic Resistances with $c \geq c_{cr}$ and $s \geq s_{cr}$						
			Use condition						
			d/d			w/d			d/d
			w/w			w/w			w/w
			40°C/24°C	80°C/50°C	120°C/72°C	40°C/24°C	80°C/50°C	120°C/72°C	All temperature ranges
h_{ef}	$N_{Rk,b} = N_{Rk,p}^{2)}$			$N_{Rk,b} = N_{Rk,p}^{2)}$			$V_{Rk,b}^{2)}$		
[mm]	[kN]								
Normalised mean compressive strength $f_b \geq 10 \text{ N/mm}^2$ 1)									
M8	SH 12	80	1,2			3,0			
M8 / M10/ IG-M6	SH 16	≥ 85	1,2			3,0			
		130	1,5			3,5			
M12 / M16/ IG-M8 / IG-M10	SH 20	≥ 85	1,2			4,0			
		≥ 130	1,5			4,0			

1) For lower compressive strengths resistances must be multiplied by the conversion factor according to Table C64. For stones with higher strengths, the shown values are valid without conversion.

2) $N_{Rk,b,c} = N_{Rk,p,c}$ and $V_{Rk,c \parallel} = V_{Rk,c \perp}$ according to Annex C 3

Table C70: Displacements

Anchor size	h_{ef}	$\delta N / N$	δN_0	δN_{∞}	$\delta V / V$	δV_0	δV_{∞}
	[mm]	[mm/kN]	[mm]	[mm]	[mm/kN]	[mm]	[mm]
M8 – M12 / IG-M6 – M10	all	0,13	0,13 * $N_{Rk} / 3,5$	2 * δN_0	0,55	0,55 * $V_{Rk} / 3,5$	1,5 * δV_0
M16	all				0,31	0,31 * $V_{Rk} / 3,5$	1,5 * δV_0


Injection system TILCA TIM V+, TIM V+ Frost for masonry

Performances hollow clay brick Porotherm Homebric
Group factors, characteristic Resistances and Displacements

Annex C 22

Brick type: Hollow Clay brick BGV Thermo

Table C71: Stone description

Brick type	Hollow clay brick BGV Thermo		
Density	ρ [kg/dm ³]	$\geq 0,60$	
Normalised mean compressive strenght	f_b [N/mm ²]	≥ 10	
Conversion factor for lower compressive strengths	$(f_b / 10)^{0,5} \leq 1,0$		
Code	EN 771-1:2011+A1:2015		
Producer (Country)	e.g. Leroux (FR)		
Brick dimensions	[mm]	500 x 200 x 314	
Drilling method	Rotary drilling		

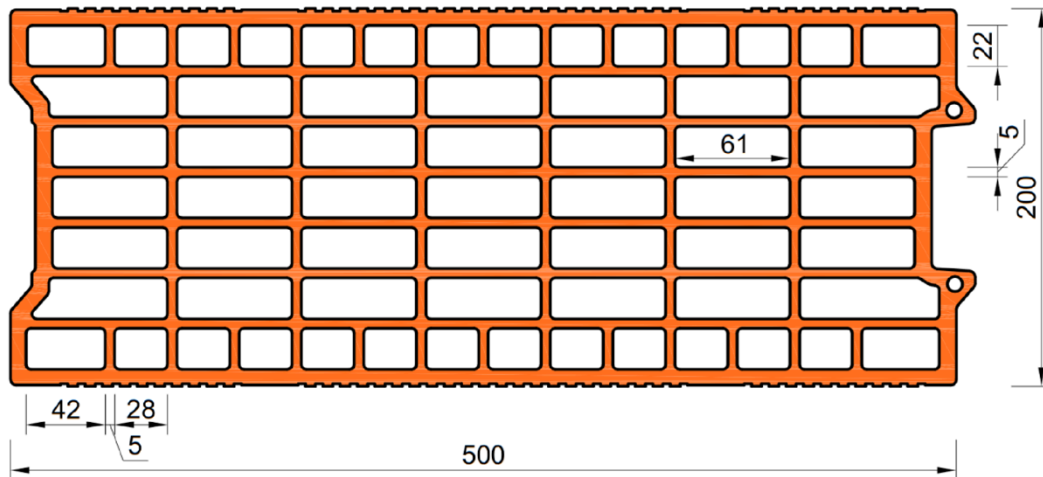
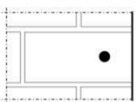
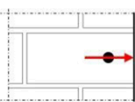
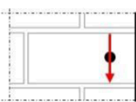


Table C72: Installation parameter

Anchor size		[-]	M8	M10	M12	M16	IG-M6	IG-M8	IG-M10
Installation torque	T_{inst}	[Nm]	≤ 2	≤ 2	≤ 2	≤ 2	≤ 2	≤ 2	≤ 2
Char. Edge distance	c_{cr}	[mm]	120 (for shear loads perpendicular to the free edge: $c_{cr} = 500$)						
Minimum Edge Distance	c_{min}	[mm]	120						
Characteristic Spacing	$s_{cr, II}$	[mm]	500						
	$s_{cr, \perp}$	[mm]	315						
Minimum Spacing	$s_{min, II}$ $s_{min, \perp}$	[mm]	120						

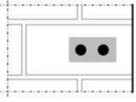
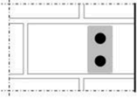
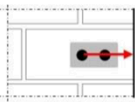
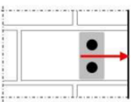
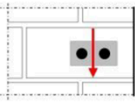
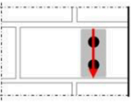
Table C73: Reduction factors for single anchors at the edge

Tension load			Shear load					
			Perpendicular to the free edge			Parallel to the free edge		
	with $c \geq$	$\alpha_{edge, N}$		with $c \geq$	$\alpha_{edge, V \perp}$		with $c \geq$	$\alpha_{edge, V II}$
	120	1,00		120	0,30		120	0,60
	120	1,00		250	0,60		250	1,00
	120	1,00		500	1,00		500	1,00

Injection system TILCA TIM V+, TIM V+ Frost for masonry

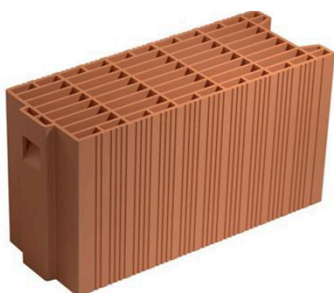
Performances hollow clay brick BGV Thermo
Description of the stone, Installation parameters, Reductionfactors

Annex C 23

Brick type: Hollow Clay brick BGV Thermo									
Table C74: Factors for anchor groups under tension load									
Anchor position parallel to hor. joint				Anchor position perpendicular to hor. joint					
	with $c \geq$	with $s \geq$	$\alpha_{g II, N}$		with $c \geq$	with $s \geq$	$\alpha_{g \perp, N}$		
	120	100	1,00		120	100	1,00		
	200	100	1,70		200	100	1,10		
	120	500	2,00		120	315	2,00		
Table C75: Factors for anchor groups under shear load									
Anchor position parallel to hor. joint				Anchor position perpendicular to hor. joint					
Shear load perpendicular to the free edge		with $c \geq$	with $s \geq$	$\alpha_{g II, V \perp}$		with $c \geq$	with $s \geq$	$\alpha_{g \perp, V \perp}$	
		120	100	1,00		120	100	1,00	
		120	500	2,00		120	315	2,00	
Shear load parallel to the free edge		with $c \geq$	with $s \geq$	$\alpha_{g II, V II}$		with $c \geq$	with $s \geq$	$\alpha_{g \perp, V II}$	
		120	100	1,00		120	100	1,00	
		120	500	2,00		120	315	2,00	
Table C76: Characteristic values of tension and shear load resistances									
Anchor size	Perforated sleeve	Effective Anchorage depth	Characteristic Resistances with $c \geq c_{cr}$ and $s \geq s_{cr}$					All temperature ranges	
			Use condition						
			d/d			w/d w/w			d/d w/d w/w
			40°C/24°C	80°C/50°C	120°C/72°C	40°C/24°C	80°C/50°C		120°C/72°C
			$N_{Rk,b} = N_{Rk,p}^{2)}$			$N_{Rk,b} = N_{Rk,p}^{2)}$			$V_{Rk,b}^{2)}$
		[mm]	[kN]						
Normalised mean compressive strength $f_b \geq 10 \text{ N/mm}^2$ 1)									
M8	SH 12	80	0,9				3,5		
M8 / M10/ IG-M6	SH 16	≥ 85	0,9				3,5		
		130	2,0	1,5	2,0	1,5	4,0		
M12 / M16 IG-M8 / IG-M10	SH 20	≥ 85	0,9				4,0		
		≥ 130	2,0	1,5	2,0	1,5	4,0		
1) For lower compressive strengths resistances must be multiplied by the conversion factor according to Table C71. For stones with higher strengths, the shown values are valid without conversion.									
2) $N_{Rk,b,c} = N_{Rk,p,c}$ and $V_{Rk,c II} = V_{Rk,c \perp}$ according to Annex C 3									
Table C77: Displacements									
Anchor size	h_{ef}	δ_N / N	δ_{N0}	$\delta_{N\infty}$	δ_V / V	δ_{V0}	$\delta_{V\infty}$		
	[mm]	[mm/kN]	[mm]	[mm]	[mm/kN]	[mm]	[mm]		
M8 – M12 / IG-M6 – M10	all	0,13	0,13 * $N_{Rk} / 3,5$	2 * δ_{N0}	0,55	0,55 * $V_{Rk} / 3,5$	1,5 * δ_{V0}		
	M16				all	0,31	0,31 * $V_{Rk} / 3,5$	1,5 * δ_{V0}	
Injection system TILCA TIM V+, TIM V+ Frost for masonry						Annex C 24			
Performances hollow clay brick BGV Thermo Group factors, characteristic Resistances and Displacements									

Brick type: Hollow Clay brick Calibric R+

Table C78: Stone description

Brick type	Hollow clay brick Calibric R+		
Density	ρ [kg/dm ³]	≥ 0,60	
Normalised mean compressive strength	f_b [N/mm ²]	≥ 12	
Conversion factor for lower compressive strengths	$(f_b / 12)^{0,5} \leq 1,0$		
Code	EN 771-1:2011+A1:2015		
Producer (Country)	e.g. Leroux (FR)		
Brick dimensions	[mm]	500 x 200 x 314	
Drilling method	Rotary drilling		

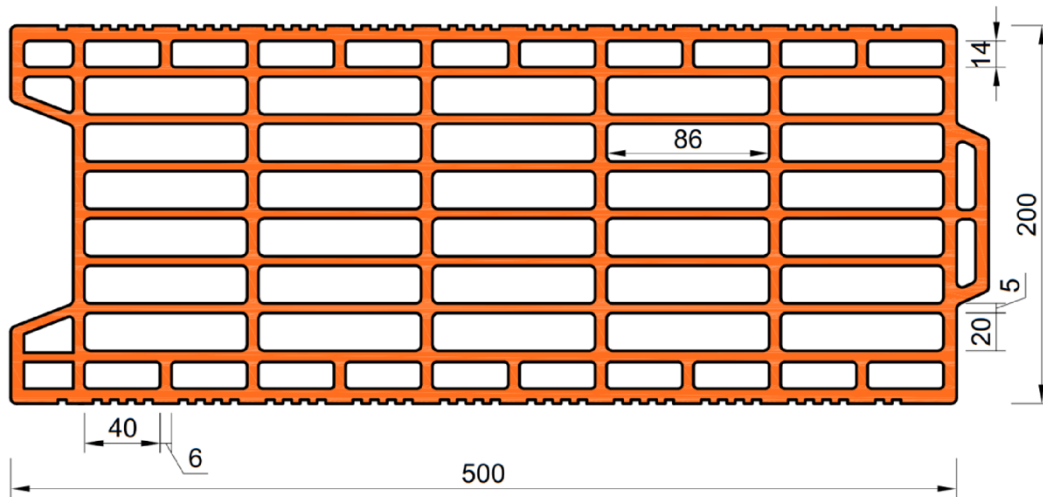
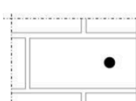
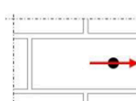
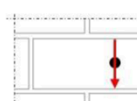


Table C79: Installation parameter

Anchor size		[-]	M8	M10	M12	M16	IG-M6	IG-M8	IG-M10
Installation torque	T_{inst}	[Nm]	≤ 2	≤ 2	≤ 2	≤ 2	≤ 2	≤ 2	≤ 2
Char. Edge distance	c_{cr}	[mm]	120 (for shear loads perpendicular to the free edge: $c_{cr} = 500$)						
Minimum Edge Distance	c_{min}	[mm]	120						
Characteristic Spacing	$s_{cr, II}$	[mm]	500						
	$s_{cr, \perp}$	[mm]	315						
Minimum Spacing	$s_{min, II}; s_{min, \perp}$	[mm]	120						

Table C80: Reduction factors for single anchors at the edge

Tension load			Shear load					
			Perpendicular to the free edge			Parallel to the free edge		
	with $c \geq$	$\alpha_{edge, N}$		with $c \geq$	$\alpha_{edge, V \perp}$		with $c \geq$	$\alpha_{edge, V II}$
	120	1,00		120	0,15		120	0,30
	120	1,00		250	0,30		250	1,00
	120	1,00		500	1,00		500	1,00

Injection system TILCA TIM V+, TIM V+ Frost for masonry

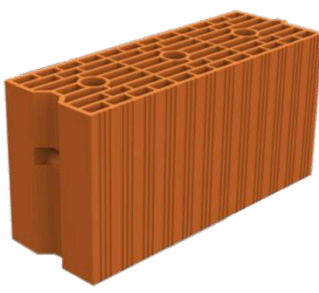
Performances hollow clay brick Calibric R+
Description of the stone, Installation parameters, Reductionfactors

Annex C 25

Brick type: Hollow Clay brick Calibric R+										
Table C81: Factors for anchor groups under tension load										
Anchor position parallel to hor. joint					Anchor position perpendicular to hor. joint					
	with $c \geq$	with $s \geq$	$\alpha_{g II, N}$			with $c \geq$	with $s \geq$	$\alpha_{g \perp, N}$		
	120	100	1,00			120	100	1,00		
	175	100	1,70			175	100	1,10		
	120	500	2,00			120	315	2,00		
Table C82: Factors for anchor groups under shear load										
Anchor position parallel to hor. joint					Anchor position perpendicular to hor. joint					
Shear load perpendicular to the free edge		with $c \geq$	with $s \geq$	$\alpha_{g II, V \perp}$			with $c \geq$	with $s \geq$	$\alpha_{g \perp, V \perp}$	
		120	100	1,00			120	100	1,00	
		120	500	2,00			120	315	2,00	
Shear load parallel to the free edge		with $c \geq$	with $s \geq$	$\alpha_{g II, V II}$			with $c \geq$	with $s \geq$	$\alpha_{g \perp, V II}$	
		120	100	1,00			120	100	1,00	
		120	500	2,00			120	315	2,00	
Table C83: Characteristic values of tension and shear load resistances										
Anchor size	Perforated sleeve	Effective Anchorage depth	Characteristic Resistances with $c \geq c_{cr}$ and $s \geq s_{cr}$							All temperature ranges
			Use condition							
			d/d			w/d w/w			d/d w/d w/w	
			40°C/24°C	80°C/50°C	120°C/72°C	40°C/24°C	80°C/50°C	120°C/72°C		
			$N_{RK,b} = N_{RK,p}^{2)}$			$N_{RK,b} = N_{RK,p}^{2)}$			$V_{RK,b}^{2)}$	
[mm]		[kN]								
Normalised mean compressive strength $f_b \geq 12 \text{ N/mm}^2$ 1)										
M8	SH 12	80	1,2	1,2	0,9	1,2	1,2	0,9	4,0	
M8 / M10/ IG-M6	SH 16	≥ 85	1,2	1,2	0,9	1,2	1,2	0,9	5,5	
		130	1,5	1,5	1,2	1,5	1,5	1,2	5,5	
M12 / M16 IG-M8 /IG-M10	SH 20	≥ 85	1,2	1,2	0,9	1,2	1,2	0,9	8,5	
		≥ 130	1,5	1,5	1,2	1,5	1,5	1,2	8,5	
1) For lower compressive strengths resistances must be multiplied by the conversion factor according to Table C78. For stones with higher strengths, the shown values are valid without conversion.										
2) $N_{RK,b,c} = N_{RK,p,c}$ and $V_{RK,c II} = V_{RK,c \perp}$ according to Annex C 3										
Table C84: Displacements										
Anchor size	h_{ef}	$\delta N / N$	δN_0	δN_{∞}	$\delta V / V$	δV_0	δV_{∞}			
	[mm]	[mm/kN]	[mm]	[mm]	[mm/kN]	[mm]	[mm]			
M8 – M12 / IG-M6 – M10	all	0,13	0,13* $N_{RK} / 3,5$	2* δN_0	0,55	0,55* $V_{RK} / 3,5$	1,5* δV_0			
	M16				0,31	0,31* $V_{RK} / 3,5$	1,5* δV_0			
Injection system TILCA TIM V+, TIM V+ Frost for masonry							Annex C 26			
Performances hollow Clay brick Calibric R+ Group factors, characteristic Resistances and Displacements										

Brick type: Hollow Clay brick Urbanbric

Table C85: Stone description

Brick type	Hollow clay brick Urbanbric		
Density	ρ [kg/dm ³]	≥ 0,70	
Normalised mean compressive strength	f_b [N/mm ²]	≥ 12	
Conversion factor for lower compressive strengths	$(f_b / 12)^{0,5} \leq 1,0$		
Code	EN 771-1:2011+A1:2015		
Producer (Country)	e.g. Imerys (FR)		
Brick dimensions	[mm]	560 x 200 x 274	
Drilling method	Rotary drilling		

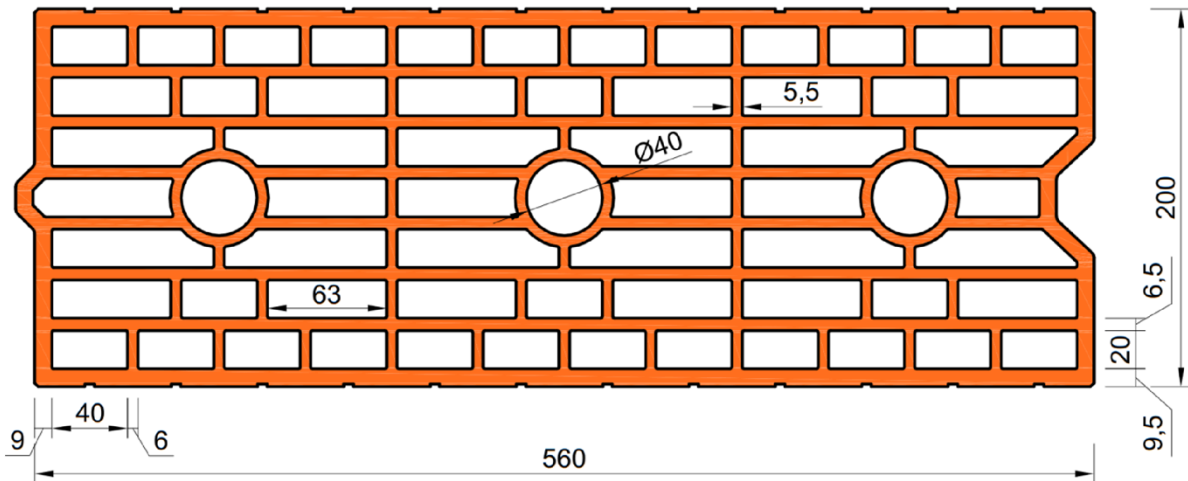
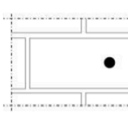
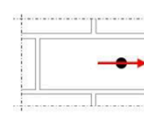
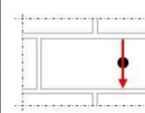


Table C86: Installation parameter

Anchor size		[-]	M8	M10	M12	M16	IG-M6	IG-M8	IG-M10
Installation torque	T_{inst}	[Nm]	≤ 2	≤ 2	≤ 2	≤ 2	≤ 2	≤ 2	≤ 2
Char. Edge distance	c_{cr}	[mm]	120 (for shear loads perpendicular to the free edge: $c_{cr} = 500$)						
Minimum Edge Distance	c_{min}	[mm]	120						
Characteristic Spacing	$s_{cr, II}$	[mm]	560						
	$s_{cr, \perp}$	[mm]	275						
Minimum Spacing	$s_{min, II}$ $s_{min, \perp}$	[mm]	100						

Table C87: Reduction factors for single anchors at the edge

Tension load			Shear load					
			Perpendicular to the free edge			Parallel to the free edge		
	with $c \geq$	$\alpha_{edge, N}$		with $c \geq$	$\alpha_{edge, V \perp}$		with $c \geq$	$\alpha_{edge, V II}$
	120	1,00		120	0,25		120	0,50
	120	1,00		250	0,50		250	1,00
	120	1,00		500	1,00		250	1,00

Injection system TILCA TIM V+, TIM V+ Frost for masonry


Performances hollow clay brick Urbanbric
Description of the stone, Installation parameters, Reductionfactors

Annex C 27

Brick type: Hollow Clay brick Urbanbric										
Table C88: Factors for anchor groups under tension load										
Anchor position parallel to hor. joint					Anchor position perpendicular to hor. joint					
	with c ≥	with s ≥	$\alpha_{g II, N}$			with c ≥	with s ≥	$\alpha_{g \perp, N}$		
	120	100	1,00			120	100	1,00		
	185	100	1,90			185	100	1,10		
	120	560	2,00			120	275	2,00		
Table C89: Factors for anchor groups under shear load										
Anchor position parallel to hor. joint					Anchor position perpendicular to hor. joint					
Shear load perpendicular to the free edge		with c ≥	with s ≥	$\alpha_{g II, V \perp}$			with c ≥	with s ≥	$\alpha_{g \perp, V \perp}$	
		120	100	1,00			120	100	1,00	
		120	560	2,00			120	275	2,00	
Shear load parallel to the free edge		with c ≥	with s ≥	$\alpha_{g II, V II}$			with c ≥	with s ≥	$\alpha_{g \perp, V II}$	
		120	100	1,00			120	100	1,00	
		120	560	2,00			120	275	2,00	
Table C90: Characteristic values of tension and shear load resistances										
Anchor size	Perforated sleeve	Effective Anchorage depth	Characteristic Resistances with c ≥ c _{cr} and s ≥ s _{cr}							All temperature ranges
			Use condition							
			d/d			w/d w/w			d/d w/d w/w	
			40°C/24°C	80°C/50°C	120°C/72°C	40°C/24°C	80°C/50°C	120°C/72°C		
			h _{ef}			N _{Rk,b} = N _{Rk,p} ²⁾			N _{Rk,b} = N _{Rk,p} ²⁾	
	[mm]	[kN]								
Normalised mean compressive strength f _b ≥ 12 N/mm ² 1)										
M8	SH 12	80	1,2	1,2	0,9	1,2	1,2	0,9	4,5	
M8 / M10/ IG-M6	SH 16	≥ 85	1,2	1,2	0,9	1,2	1,2	0,9	4,5	
		130	3,0	3,0	2,5	3,0	3,0	2,5	4,5	
M12 / M16 IG-M8 / IG-M10	SH 20	≥ 85	1,2	1,2	0,9	1,2	1,2	0,9	5,0	
		≥ 130	3,0	3,0	2,5	3,0	3,0	2,5	5,0	
1) For lower compressive strengths resistances must be multiplied by the conversion factor according to Table C85. For stones with higher strengths, the shown values are valid without conversion.										
2) N _{Rk,b,c} = N _{Rk,p,c} and V _{Rk,c II} = V _{Rk,c ⊥} according to Annex C 3										
Table C91: Displacements										
Anchor size	h _{ef}	$\delta N / N$	δN_0	δN_{∞}	$\delta V / V$	δV_0	δV_{∞}			
	[mm]	[mm/kN]	[mm]	[mm]	[mm/kN]	[mm]	[mm]			
M8 – M12 / IG-M6 – M10	all	0,13	0,13*N _{Rk} / 3,5	2* δN_0	0,55	0,55*V _{Rk} / 3,5	1,5* δV_0			
M16	all				0,31	0,31*V _{Rk} / 3,5	1,5* δV_0			
Injection system TILCA TIM V+, TIM V+ Frost for masonry							Annex C 28			
Performances hollow clay brick Urbanbric Group factors, characteristic Resistances and Displacements										

Brick type: Hollow Clay brick Brique creuse C40

Table C92: Stone description

Brick type	Hollow clay brick Brique creuse C40		
Density ρ [kg/dm ³]	$\geq 0,70$		
Normalised mean compressive strength f_b [N/mm ²]	≥ 12		
Conversion factor for lower compressive strengths	$(f_b / 12)^{0,5} \leq 1,0$		
Code	EN 771-1:2011+A1:2015		
Producer (Country)	e.g. Terreal (FR)		
Brick dimensions [mm]	500 x 200 x 200		
Drilling method	Rotary drilling		

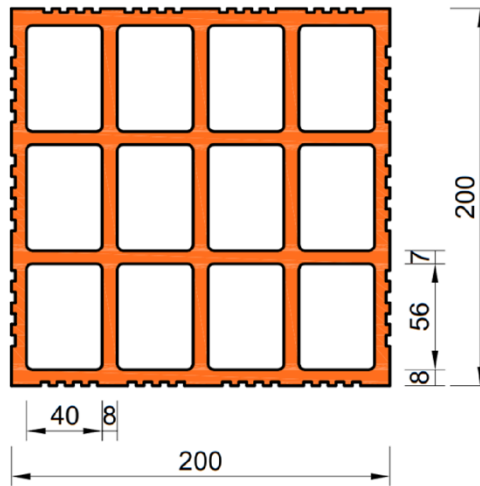
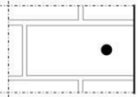
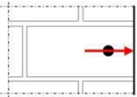
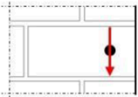


Table C93: Installation parameter

Anchor size		[-]	M8	M10	M12	M16	IG-M6	IG-M8	IG-M10
Installation torque	T_{inst}	[Nm]	≤ 2	≤ 2	≤ 2	≤ 2	≤ 2	≤ 2	≤ 2
Char. Edge distance	c_{cr}	[mm]	120 (for shear loads perpendicular to the free edge: $c_{cr} = 500$)						
Minimum Edge Distance	c_{min}	[mm]	120						
Characteristic Spacing	$s_{cr, II}$	[mm]	500						
	$s_{cr, \perp}$	[mm]	200						
Minimum Spacing	$s_{min, II}$ $s_{min, \perp}$	[mm]	200						

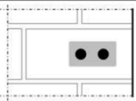
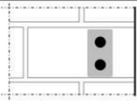
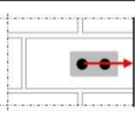
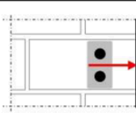
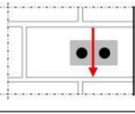
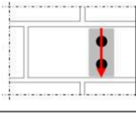
Table C94: Reduction factors for single anchors at the edge

Tension load			Shear load					
			Perpendicular to the free edge			Parallel to the free edge		
	with $c \geq$	$\alpha_{edge, N}$		with $c \geq$	$\alpha_{edge, V \perp}$		with $c \geq$	$\alpha_{edge, V II}$
	120	1,00		120	0,83		120	1,00
	120	1,00		500	1,00		250	1,00

Injection system TILCA TIM V+, TIM V+ Frost for masonry


Performances hollow clay brick Brique Creuse C40
Description of the stone, Installation parameters, Reductionfactors

Annex C 29

Brick type: Hollow Clay brick Brique creuse C40										
Table C95: Factors for anchor groups under tension load										
Anchor position parallel to hor. joint					Anchor position perpendicular to hor. joint					
	with $c \geq$	with $s \geq$	$\alpha_{g II, N}$			with $c \geq$	with $s \geq$	$\alpha_{g \perp, N}$		
	120	500	2,00			120	200	2,00		
Table C96: Factors for anchor groups under shear load										
Anchor position parallel to hor. joint					Anchor position perpendicular to hor. joint					
Shear load perpendicular to the free edge		with $c \geq$	with $s \geq$	$\alpha_{g II, V \perp}$			with $c \geq$	with $s \geq$	$\alpha_{g \perp, V \perp}$	
		120	500	2,00			120	200	2,00	
Shear load parallel to the free edge		with $c \geq$	with $s \geq$	$\alpha_{g II, V II}$			with $c \geq$	with $s \geq$	$\alpha_{g \perp, V II}$	
		120	500	2,00			120	200	2,00	
Table C97: Characteristic values of tension and shear load resistances										
Anchor size	Perforated sleeve	Effective Anchorage depth	Characteristic Resistances with $c \geq c_{cr}$ and $s \geq s_{cr}$							All temperature ranges
			Use condition							
			d/d			w/d w/w			d/d w/d w/w	
			40°C/24°C	80°C/50°C	120°C/72°C	40°C/24°C	80°C/50°C	120°C/72°C		
			$N_{Rk,b} = N_{Rk,p}^{2)}$			$N_{Rk,b} = N_{Rk,p}^{2)}$			$V_{Rk,b}^{2)}$	
	h_{ef}	[mm]							[kN]	
Normalised mean compressive strength $f_b \geq 12 \text{ N/mm}^2$ 1)										
M8	SH 12	80	1,2	1,2	0,9	1,2	1,2	0,9	1,5	
M8 / M10 / IG-M6	SH 16	≥ 85								
M12 / M16 / IG-M8 / IG-M10	SH 20	≥ 85								
<p>1) For lower compressive strengths resistances must be multiplied by the conversion factor according to Table C92. For stones with higher strengths, the shown values are valid without conversion.</p> <p>2) $N_{Rk,b,c} = N_{Rk,p,c}$ and $V_{Rk,c II} = V_{Rk,c \perp}$ according to Annex C 3</p>										
Table C98: Displacements										
Anchor size	h_{ef}	$\delta N / N$	δN_0	δN_{∞}	$\delta V / V$	δV_0	δV_{∞}			
	[mm]	[mm/kN]	[mm]	[mm]	[mm/kN]	[mm]	[mm]			
M8 – M12 / IG-M6 – M10	all	0,13	0,13 * $N_{Rk} / 3,5$	2 * δN_0	0,55	0,55 * $V_{Rk} / 3,5$	1,5 * δV_0			
M16	all				0,31	0,31 * $V_{Rk} / 3,5$	1,5 * δV_0			
Injection system TILCA TIM V+, TIM V+ Frost for masonry							Annex C 30			
Performances hollow clay brick Brique Creuse C40 Group factors, characteristic Resistances and Displacements										

Brick type: Hollow Clay brick Blocchi Leggeri

Table C99: Stone description

Brick type	Hollow clay brick Blocchi Leggeri		
Density	ρ [kg/dm ³]	≥ 0,60	
Normalised mean compressive strength	f_b [N/mm ²]	≥ 12	
Conversion factor for lower compressive strengths	$(f_b / 12)^{0,5} \leq 1,0$		
Code	EN 771-1:2011+A1:2015		
Producer (Country)	e.g. Wienerberger (IT)		
Brick dimensions	[mm]	250 x 120 x 250	
Drilling method	Rotary drilling		

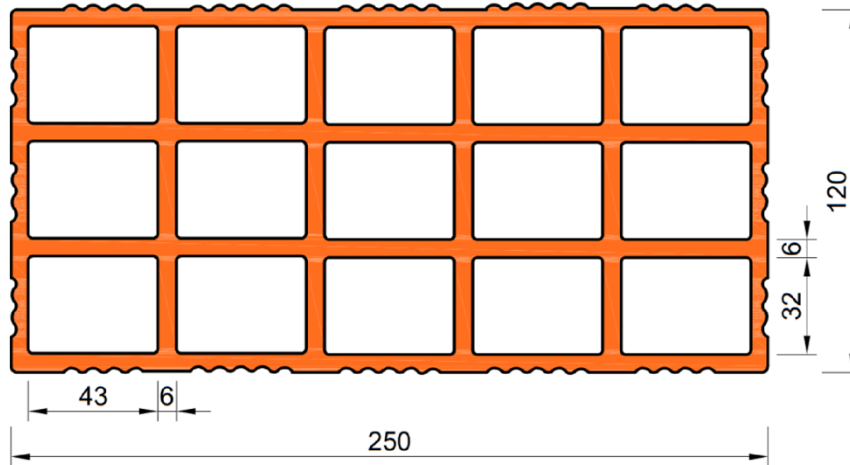
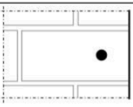
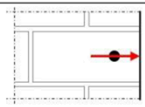
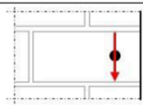


Table C100: Installation parameter

Anchor size		[-]	M8	M10	M12	M16	IG-M6	IG-M8	IG-M10
Installation torque	T_{inst}	[Nm]	≤ 2	≤ 2	≤ 2	≤ 2	≤ 2	≤ 2	≤ 2
Char. Edge distance	c_{cr}	[mm]	120 (for shear loads perpendicular to the free edge: $c_{cr} = 250$)						
Minimum Edge Distance	c_{min}	[mm]	60						
Characteristic Spacing	$s_{cr, II}$	[mm]	250						
	$s_{cr, \perp}$	[mm]	250						
Minimum Spacing	$s_{min, II}; s_{min, \perp}$	[mm]	100						

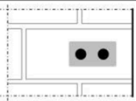
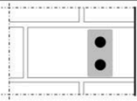
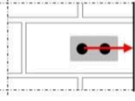
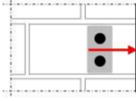
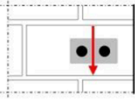
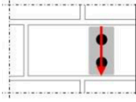
Table C101: Reduction factors for single anchors at the edge

Tension load			Shear load					
			Perpendicular to the free edge			Parallel to the free edge		
	with $c \geq$	$\alpha_{edge, N}$		with $c \geq$	$\alpha_{edge, V \perp}$		with $c \geq$	$\alpha_{edge, V II}$
	60	1,00		60	0,40		60	0,40
	120	1,00		250	1,00		120	1,00

Injection system TILCA TIM V+, TIM V+ Frost for masonry

Performances hollow clay brick Blocchi Leggeri
Description of the stone, Installation parameters, Reductionfactors

Annex C 31

Brick type: Hollow Clay brick Blocchi Leggeri										
Table C102: Factors for anchor groups under tension load										
Anchor position parallel to hor. joint					Anchor position perpendicular to hor. joint					
	with $c \geq$	with $s \geq$	$\alpha_{g II, N}$			with $c \geq$	with $s \geq$	$\alpha_{g \perp, N}$		
	60	100	1,00			60	100	2,00		
	120	250	2,00			120	250	2,00		
Table C103: Factors for anchor groups under shear load										
Anchor position parallel to hor. joint					Anchor position perpendicular to hor. joint					
Shear load perpendicular to the free edge		with $c \geq$	with $s \geq$	$\alpha_{g II, V \perp}$			with $c \geq$	with $s \geq$	$\alpha_{g \perp, V \perp}$	
		60	100	0,40			60	100	0,40	
		250	100	1,00			250	100	1,00	
		250	250	2,00				2,00		
Shear load parallel to the free edge		with $c \geq$	with $s \geq$	$\alpha_{g II, V \parallel}$			with $c \geq$	with $s \geq$	$\alpha_{g \perp, V \parallel}$	
		60	100	0,40			60	100	0,40	
		120	100	1,00			120	100	1,00	
		120	250	2,00				2,00		
Table C104: Characteristic values of tension and shear load resistances										
Anchor size	Perforated sleeve	Effective Anchorage depth	Characteristic Resistances with $c \geq c_{cr}$ and $s \geq s_{cr}$							
			Use condition							
			d/d			w/d			d/d	
			w/w			w/w			w/w	
			40°C/24°C	80°C/50°C	120°C/72°C	40°C/24°C	80°C/50°C	120°C/72°C	All temperature ranges	
h_{ef}	$N_{Rk,b} = N_{Rk,p}^{2)}$			$N_{Rk,b} = N_{Rk,p}^{2)}$			$V_{Rk,b}^{2)}$			
[mm]	[kN]									
Normalised mean compressive strength $f_b \geq 12 \text{ N/mm}^2$ 1)										
M8	SH 12	80								
M8 / M10 / IG-M6	SH 16	≥ 85	0,6	0,6	0,6	0,6	0,6	0,6	3,5	
M12 / M16 / IG-M8 / IG-M10	SH 20	≥ 85								
1) For lower compressive strengths resistances must be multiplied by the conversion factor according to Table C99. For stones with higher strengths, the shown values are valid without conversion.										
2) $N_{Rk,b,c} = N_{Rk,p,c}$ and $V_{Rk,c \parallel} = V_{Rk,c \perp}$ according to Annex C 3										
Table C105: Displacements										
Anchor size	h_{ef}	$\delta N / N$	δN_0	δN_{∞}	$\delta V / V$	δV_0	δV_{∞}			
	[mm]	[mm/kN]	[mm]	[mm]	[mm/kN]	[mm]	[mm]			
M8 – M12 / IG-M6 – M10	all	0,13	$0,13 \cdot N_{Rk} / 3,5$	$2 \cdot \delta N_0$	0,55	$0,55 \cdot V_{Rk} / 3,5$	$1,5 \cdot \delta V_0$			
M16	all				0,31	$0,31 \cdot V_{Rk} / 3,5$	$1,5 \cdot \delta V_0$			
Injection system TILCA TIM V+, TIM V+ Frost for masonry							Annex C 32			
Performances hollow clay brick Blocchi Leggeri Group factors, characteristic Resistances and Displacements										

Brick type: Hollow Clay brick Doppio Uni

Table C106: Stone description

Brick type	Hollow clay brick Doppio Uni	
Density ρ [kg/dm ³]	$\geq 0,90$	
Normalised mean compressive strenght f_b [N/mm ²]	≥ 28	
Conversion factor for lower compressive strengths	$(f_b / 28)^{0,5} \leq 1,0$	
Code	EN 771-1:2011+A1:2015	
Producer (Country)	e.g. Wienerberger (IT)	
Brick dimensions [mm]	250 x 120 x 120	
Drilling method	Rotary drilling	

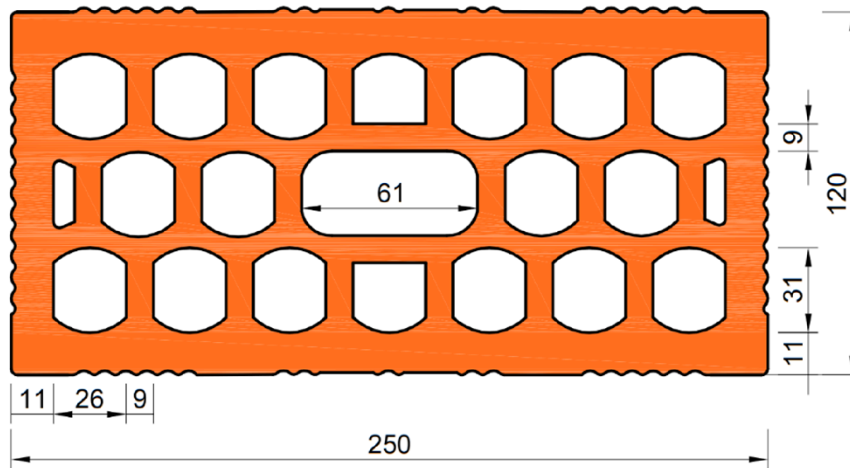
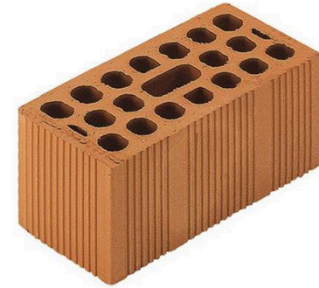


Table C107: Installation parameter

Anchor size		[-]	M8	M10	M12	M16	IG-M6	IG-M8	IG-M10
Installation torque	T_{inst}	[Nm]	≤ 2	≤ 2	≤ 2	≤ 2	≤ 2	≤ 2	≤ 2
Char. Edge distance	c_{cr}	[mm]	120 (for shear loads perpendicular to the free edge: $c_{cr} = 250$)						
Minimum Edge Distance	c_{min}	[mm]	100						
Characteristic Spacing	$s_{cr, II}$	[mm]	250						
	$s_{cr, \perp}$	[mm]	120						
Minimum Spacing	$s_{min, II}$ $s_{min, \perp}$	[mm]	100						

Table C108: Reduction factors for single anchors at the edge

Tension load			Shear load					
			Perpendicular to the free edge			Parallel to the free edge		
	with $c \geq$	$\alpha_{edge, N}$		with $c \geq$	$\alpha_{edge, V \perp}$		with $c \geq$	$\alpha_{edge, V II}$
	100	1,00		100	0,50		100	1,00
	120	1,00		250	1,00		120	1,00

Injection system TILCA TIM V+, TIM V+ Frost for masonry

Performances hollow clay brick Doppio Uni
Description of the stone, Installation parameters, Reductionfactors

Annex C 33

Brick type: Hollow Clay brick Doppio Uni

Table C109: Factors for anchor groups under tension load

Anchor position parallel to hor. joint				Anchor position perpendicular to hor. joint			
	with $c \geq$	with $s \geq$	$\alpha_{g II, N}$		with $c \geq$	with $s \geq$	$\alpha_{g \perp, N}$
	100	100	1,00		100	120	2,00
	120	250	2,00		120	120	2,00

Table C110: Factors for anchor groups under shear load

	Anchor position parallel to hor. joint				Anchor position perpendicular to hor. joint			
Shear load perpendicular to the free edge		with $c \geq$	with $s \geq$	$\alpha_{g II, V \perp}$		with $c \geq$	with $s \geq$	$\alpha_{g \perp, V \perp}$
		100	100	1,00		100	100	1,00
		250	250	2,00		250	120	2,00
Shear load parallel to the free edge		with $c \geq$	with $s \geq$	$\alpha_{g II, V \parallel}$		with $c \geq$	with $s \geq$	$\alpha_{g \perp, V \parallel}$
		100	100	1,00		100	100	1,00
		120	250	2,00		120	120	2,00

Table C111: Characteristic values of tension and shear load resistances

Anchor size	Perforated sleeve	Effective Anchorage depth	Characteristic Resistances with $c \geq c_{cr}$ and $s \geq s_{cr}$						
			Use condition						
			d/d			w/d w/w			d/d w/d w/w
			40°C/24°C	80°C/50°C	120°C/72°C	40°C/24°C	80°C/50°C	120°C/72°C	All temperature ranges
	h_{ef}	$N_{Rk,b} = N_{Rk,p}^{2)}$			$N_{Rk,b} = N_{Rk,p}^{2)}$			$V_{Rk,b}^{2)}$	
	[mm]	[kN]							

Normalised mean compressive strength $f_b \geq 28 \text{ N/mm}^2$ 1)

Anchor size	SH	Effective Anchorage depth	40°C/24°C	80°C/50°C	120°C/72°C	40°C/24°C	80°C/50°C	120°C/72°C	All temperature ranges
M8	SH 12	80	1,2	1,2	0,9	1,2	1,2	0,9	2,5
M8 / M10 / IG-M6	SH 16	≥ 85							
M12 / M16 / IG-M8 / IG-M10	SH 20	≥ 85							

1) For lower compressive strengths resistances must be multiplied by the conversion factor according to Table C106. For stones with higher strengths, the shown values are valid without conversion.

2) $N_{Rk,b,c} = N_{Rk,p,c}$ and $V_{Rk,c \parallel} = V_{Rk,c \perp}$ according to Annex C 3

Table C112: Displacements

Anchor size	h_{ef}	$\delta N / N$	δN_0	δN_{∞}	$\delta V / V$	δV_0	δV_{∞}
	[mm]	[mm/kN]	[mm]	[mm]	[mm/kN]	[mm]	[mm]
M8 – M12 / IG-M6 – M10	all	0,13	0,13* N_{Rk} / 3,5	2* δN_0	0,55	0,55* V_{Rk} / 3,5	1,5* δV_0
M16	all				0,31	0,31* V_{Rk} / 3,5	1,5* δV_0

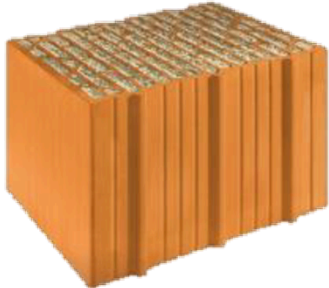
Injection system TILCA TIM V+, TIM V+ Frost for masonry

Performances hollow clay brick Doppio Uni
Group factors, characteristic Resistances and Displacements

Annex C 34

Brick type: Hollow clay brick Coriso WS07 with insulation

Table C113: Stone description

Brick type	Hollow clay brick Coriso WS07		
Insulationmaterial	Rock wool		
Density	ρ [kg/dm ³]	≥ 0,55	
Normalised mean compressive strenght	f_b [N/mm ²]	≥ 6	
Conversion factor for lower compressive strengths	$(f_b / 6)^{0,5} \leq 1,0$		
Code	EN 771-1:2011+A1:2015		
Producer (Country)	e.g. Unipor (DE)		
Brick dimensions	[mm]	248 x 365 x 249	
Drilling method	Rotary drilling		

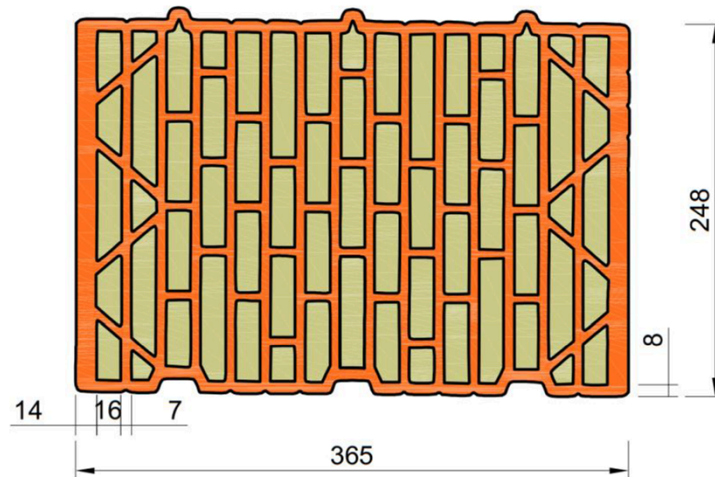
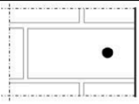
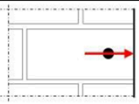
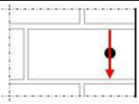


Table C114: Installation parameter

Anchor size		[-]	M8	M10	M12	M16	IG-M6	IG-M8	IG-M10
Installation torque	T_{inst}	[Nm]	≤ 5	≤ 5	≤ 10	≤ 10	≤ 5	≤ 5	≤ 5
Char. Edge distance	c_{cr}	[mm]	120 (for shear loads perpendicular to the free edge: $c_{cr} = 250$)						
Minimum Edge Distance	c_{min}	[mm]	50						
Characteristic Spacing	$s_{cr, II}$	[mm]	250						
	$s_{cr, \perp}$	[mm]	250						
Minimum Spacing	$s_{min, II}; s_{min, \perp}$	[mm]	50						

Table C115: Reduction factors for single anchors at the edge

Tension load			Shear load					
			Perpendicular to the free edge			Parallel to the free edge		
	with $c \geq$	$\alpha_{edge, N}$		with $c \geq$	$\alpha_{edge, V \perp}$		with $c \geq$	$\alpha_{edge, V II}$
	50	1,00		50	0,30		50	1,00
	120	1,00		250	1,00		120	1,00

Injection system TILCA TIM V+, TIM V+ Frost for masonry

Performances hollow clay brick Coriso WS07 with insulation
Description of the stone, Installation parameters, Reductionfactors

Annex C 35

Brick type: Hollow clay brick Coriso WS07 with insulation

Table C116: Factors for anchor groups under tension load

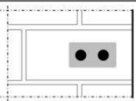
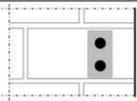
Anchor position parallel to hor. joint				Anchor position perpendicular to hor. joint			
	with $c \geq$	with $s \geq$	$\alpha_{g II, N}$		with $c \geq$	with $s \geq$	$\alpha_{g \perp, N}$
	50	50	1,50		50	50	1,00
	120	250	2,00		120	250	2,00

Table C117: Factors for anchor groups under shear load

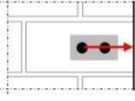
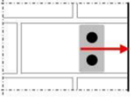
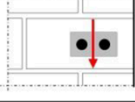
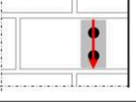
	Anchor position parallel to hor. joint				Anchor position perpendicular to hor. joint			
Shear load perpendicular to the free edge		with $c \geq$	with $s \geq$	$\alpha_{g II, V \perp}$		with $c \geq$	with $s \geq$	$\alpha_{g \perp, V \perp}$
		50	50	0,40		50	50	0,40
		250	50	1,00		250	50	1,20
Shear load parallel to the free edge		with $c \geq$	with $s \geq$	$\alpha_{g II, V II}$		with $c \geq$	with $s \geq$	$\alpha_{g \perp, V II}$
		50	50	1,65		50	50	1,00
		120	250	2,00		120	250	2,00

Table C118: Characteristic values of tension and shear load resistances

Anchor size	Perforated sleeve	Effective Anchorage depth	Characteristic Resistances with $c \geq c_{cr}$ and $s \geq s_{cr}$							
			Use condition							
			d/d			w/d w/w			d/d w/d w/w	
			40°C/24°C	80°C/50°C	120°C/72°C	40°C/24°C	80°C/50°C	120°C/72°C	All temperature ranges	
	h_{ef}	$N_{Rk,b} = N_{Rk,p}^{2)}$			$N_{Rk,b} = N_{Rk,p}^{2)}$			$V_{Rk,b}^{2)}$		
	[mm]	[kN]								

Normalised mean compressive strength $f_b \geq 6 \text{ N/mm}^2$ 1)

M8	SH 12	80								
M8 / M10 / IG-M6	SH 16	≥ 85	1,5	1,5	1,5	1,5	1,5	1,5	1,5	5,0
M12 / M16 / IG-M8 / IG-M10	SH 20	≥ 85								

1) For lower compressive strengths resistances must be multiplied by the conversion factor according to Table C113. For stones with higher strengths, the shown values are valid without conversion.

2) $N_{Rk,b,c} = N_{Rk,p,c}$ and $V_{Rk,c II} = V_{Rk,c \perp}$ according to Annex C 3

Table C119: Displacements

Anchor size	h_{ef}	$\delta N / N$	δN_0	δN_{∞}	$\delta V / V$	δV_0	δV_{∞}
	[mm]	[mm/kN]	[mm]	[mm]	[mm/kN]	[mm]	[mm]
M8 – M12 / IG-M6 – M10	all	0,13	0,13 * $N_{Rk} / 3,5$	2 * δN_0	0,55	0,55 * $V_{Rk} / 3,5$	1,5 * δV_0
M16	all				0,31	0,31 * $V_{Rk} / 3,5$	1,5 * δV_0


Injection system TILCA TIM V+, TIM V+ Frost for masonry

Performances hollow Clay brick Coriso WS07 with insulation
Group factors, characteristic Resistances and Displacements

Annex C 36

Brick type: Hollow clay brick T7 MW with insulation

Table C120: Stone description

Brick type	Hollow clay brick T7 MW		
Insulation material	Rock wool		
Density	ρ [kg/dm ³]	$\geq 0,59$	
Normalised mean compressive strenght	f_b [N/mm ²]	≥ 8	
Conversion factor for lower compressive strengths	$(f_b / 8)^{0,5} \leq 1,0$		
Code	EN 771-1:2011+A1:2015		
Producer (Country)	e.g. Wienerberger (DE)		
Brick dimensions	[mm]	248 x 365 x 249	
Drilling method	Rotary drilling		

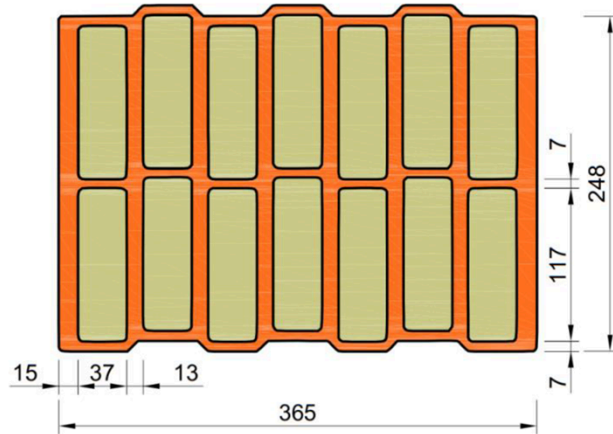


Table C121: Installation parameter

Anchor size		[-]	M8	M10	M12	M16	IG-M6	IG-M8	IG-M10
Installation torque	T_{inst}	[Nm]	≤ 5	≤ 5	≤ 10	≤ 10	≤ 5	≤ 5	≤ 5
Char. Edge distance (under fire conditions)	$c_{cr}, (c_{cr,fi})$	[mm]	120 (2 h_{ef}) (for shear loads perpendicular to the free edge: $c_{cr} = 250$)						
Minimum Edge Distance	c_{min}	[mm]	50						
Characteristic Spacing (under fire conditions)	$s_{cr, II}, (s_{cr,fi, II})$	[mm]	250 (4 h_{ef})						
	$s_{cr, \perp}, (s_{cr,fi, \perp})$	[mm]	250 (4 h_{ef})						
Minimum Spacing	$s_{min, II}, s_{min, \perp}$	[mm]	50						

Table C122: Reduction factors for single anchors at the edge

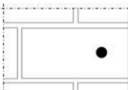


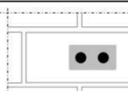
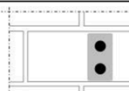
Tension load			Shear load					
			Perpendicular to the free edge			Parallel to the free edge		
	with $c \geq$	$\alpha_{edge, N}$		with $c \geq$	$\alpha_{edge, V \perp}$		with $c \geq$	$\alpha_{edge, V \parallel}$
	50	1,00		50	0,35		50	1,00
	120	1,00		250	1,00		120	1,00

Table C123: Factors for anchor groups under tension load

Anchor position parallel to hor. joint				Anchor position perpendicular to hor. joint			
	with $c \geq$	with $s \geq$	$\alpha_{g II, N}$		with $c \geq$	with $s \geq$	$\alpha_{g \perp, N}$
	50	50	1,40		50	50	1,15
	120	250	2,00		120	250	2,00

Injection system TILCA TIM V+, TIM V+ Frost for masonry

Performances hollow clay brick T7 MW with insulation
Description of the stone, Installation parameters, Reductionfactors

Annex C 37

Brick type: Hollow clay brick T7 MW with insulation

Table C124: Factors for anchor groups under shear load

	Anchor position parallel to hor. joint				Anchor position perpendicular to hor. joint			
		with $c \geq$	with $s \geq$	$\alpha_{g II, V \perp}$		with $c \geq$	with $s \geq$	$\alpha_{g \perp, V \perp}$
Shear load perpendicular to the free edge		50	50	0,60		50	50	0,40
		250	50	1,55		250	50	1,00
		250	250	2,00		250	250	2,00
Shear load parallel to the free edge		with $c \geq$	with $s \geq$	$\alpha_{g II, V \parallel}$		with $c \geq$	with $s \geq$	$\alpha_{g \perp, V \parallel}$
		50	50	2,00		50	50	1,20
		120	250	2,00		120	250	2,00

Table C125: Characteristic values of tension and shear load resistances

Anchor size	Perforated sleeve	Effective Anchorage depth	Characteristic Resistances with $c \geq c_{cr}$ and $s \geq s_{cr}$						
			Use condition						
			d/d			w/d w/w			d/d w/d w/w
			40°C/24°C	80°C/50°C	120°C/72°C	40°C/24°C	80°C/50°C	120°C/72°C	All temperature ranges
		h_{ef}	$N_{Rk,b} = N_{Rk,p}^{2)}$			$N_{Rk,b} = N_{Rk,p}^{2)}$			$V_{Rk,b}^{2)}$
		[mm]	[kN]						
Normalised mean compressive strength $f_b \geq 8 \text{ N/mm}^2$ 1)									
M8	SH 12	80							
M8 / M10/ IG-M6	SH 16	≥ 85	2,0	2,0	1,5	2,0	2,0	1,5	3,0
M12 / IG-M8	SH 20	≥ 85							
M16 / IG-M10	SH 20	≥ 85							4,5

1) For lower compressive strengths resistances must be multiplied by the conversion factor according to Table C120. For stones with higher strengths, the shown values are valid without conversion.

2) $N_{Rk,b,c} = N_{Rk,p,c}$ and $V_{Rk,c \parallel} = V_{Rk,c \perp}$ according to Annex C 3

Table C126: Displacements

Anchor size	h_{ef}	$\delta N / N$	δN_0	δN_{∞}	$\delta V / V$	δV_0	δV_{∞}
	[mm]	[mm/kN]	[mm]	[mm]	[mm/kN]	[mm]	[mm]
M8 – M12 / IG-M6 – M10	all	0,13	$0,13 \cdot N_{Rk} / 3,5$	$2 \cdot \delta N_0$	0,55	$0,55 \cdot V_{Rk} / 3,5$	$1,5 \cdot \delta V_0$
M16	all				0,31	$0,31 \cdot V_{Rk} / 3,5$	$1,5 \cdot \delta V_0$

Table C127: Characteristic values of tension and shear load resistances under fire exposure


Anchor size	Perforated sleeve	Effective Anchorage depth	Characteristic Resistances			
			$N_{Rk,b,fi} = N_{Rk,p,fi} = V_{Rk,b,fi}$			
		h_{ef}	R30	R60	R90	R120
		[mm]	[kN]			
M8 / M10 / IG-M6	SH 16	130				
M12 / M16 / IG-M8 IG-M10	SH 20	≥ 130	0,64	0,37	0,11	-1)

1) no performance assessed

Injection system TILCA TIM V+, TIM V+ Frost for masonry	Annex C 38
Performances hollow clay brick T7 MW with insulation Group factors, characteristic Resistances and Displacements	

Brick type: Hollow clay brick T8 P with insulation

Table C128: Stone description

Brick type	Hollow clay brick T8 P		
Insulation material	Perlite		
Density	ρ [kg/dm ³]	$\geq 0,56$	
Normalised mean compressive strenght	f_b [N/mm ²]	≥ 6	
Conversion factor for lower compressive strenghts	$(f_b / 6)^{0,5} \leq 1,0$		
Code	EN 771-1:2011+A1:2015		
Producer (Country)	e.g. Wienerberger (DE)		
Brick dimensions	[mm]	248 x 365 x 249	
Drilling method	Rotary drilling		

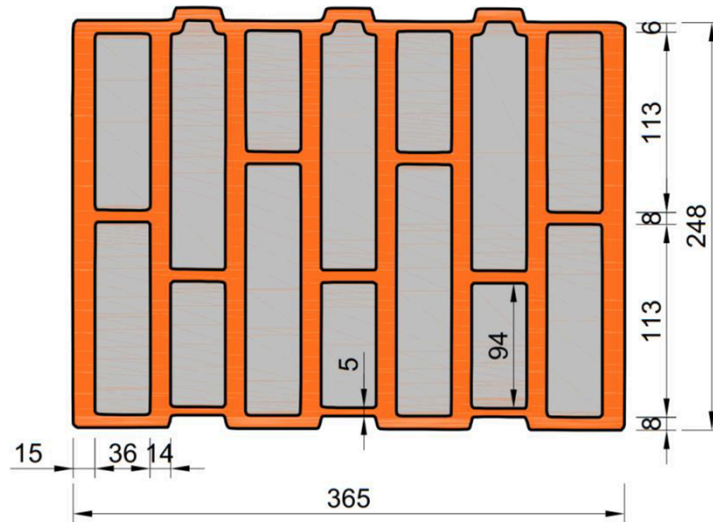
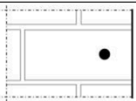
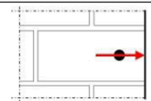
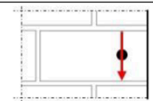


Table C129: Installation parameter

Anchor size		[-]	M8	M10	M12	M16	IG-M6	IG-M8	IG-M10
Installation torque	T_{inst}	[Nm]	≤ 4	≤ 4	≤ 10	≤ 10	≤ 4	≤ 4	≤ 4
Char. Edge distance	c_{cr}	[mm]	120 (for shear loads perpendicular to the free edge: $c_{cr} = 250$)						
Minimum Edge Distance	c_{min}	[mm]	50						
Characteristic Spacing	$s_{cr, II}$	[mm]	250						
	$s_{cr, \perp}$	[mm]	250						
Minimum Spacing	$s_{min, II}$ $s_{min, \perp}$	[mm]	50						

Table C130: Reduction factors for single anchors at the edge

Tension load			Shear load					
			Perpendicular to the free edge			Parallel to the free edge		
	with $c \geq$	$\alpha_{edge, N}$		with $c \geq$	$\alpha_{edge, V \perp}$		with $c \geq$	$\alpha_{edge, V II}$
	50	1,00		50	0,25		50	1,00
	120	1,00		250	1,00		120	1,00

Injection system TILCA TIM V+, TIM V+ Frost for masonry

Performances hollow clay brick T8 P with insulation
Description of the stone, Installation parameters, Reductionfactors

Annex C 39

Brick type: Hollow clay brick T8 P with insulation

Table C131: Factors for anchor groups under tension load

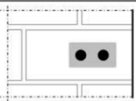
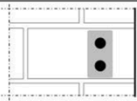
Anchor position parallel to hor. joint				Anchor position perpendicular to hor. joint			
	with $c \geq$	with $s \geq$	$\alpha_{g II, N}$		with $c \geq$	with $s \geq$	$\alpha_{g \perp, N}$
	50	50	1,30		50	50	1,10
	120	250	2,00		120	250	2,00

Table C132: Factors for anchor groups under shear load

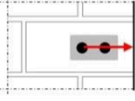
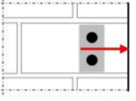
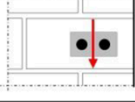
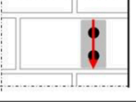
	Anchor position parallel to hor. joint				Anchor position perpendicular to hor. joint			
Shear load perpendicular to the free edge		with $c \geq$	with $s \geq$	$\alpha_{g II, V \perp}$		with $c \geq$	with $s \geq$	$\alpha_{g \perp, V \perp}$
		50	50	0,40		50	50	0,30
		250	50	1,35		250	50	1,20
Shear load parallel to the free edge		with $c \geq$	with $s \geq$	$\alpha_{g II, V II}$		with $c \geq$	with $s \geq$	$\alpha_{g \perp, V II}$
		50	50	1,70		50	50	1,00
		120	250	2,00		120	250	2,00

Table C133: Characteristic values of tension and shear load resistances

Anchor size	Perforated sleeve	Effective Anchorage depth	Characteristic Resistances with $c \geq c_{cr}$ and $s \geq s_{cr}$						
			Use condition						
			d/d			w/d w/w			d/d w/d w/w
			40°C/24°C	80°C/50°C	120°C/72°C	40°C/24°C	80°C/50°C	120°C/72°C	All temperature ranges
	h_{ef}	$N_{Rk,b} = N_{Rk,p}^{2)}$			$N_{Rk,b} = N_{Rk,p}^{2)}$			$V_{Rk,b}^{2)}$	
	[mm]	[kN]							

Normalised mean compressive strength $f_b \geq 6 \text{ N/mm}^2$ 1)

M8	SH 12	80							
M8 / M10 / IG-M6	SH 16	≥ 85	1,5	1,5	1,5	1,5	1,5	1,5	4,5
M12 / IG-M8	SH 20	≥ 85							
M16 / IG-M10	SH 20	≥ 85	2,5	2,5	2,0	2,5	2,5	2,0	7,0

1) For lower compressive strengths resistances must be multiplied by the conversion factor according to Table C128. For stones with higher strengths, the shown values are valid without conversion.

2) $N_{Rk,b,c} = N_{Rk,p,c}$ and $V_{Rk,c II} = V_{Rk,c \perp}$ according to Annex C 3

Table C134: Displacements

Anchor size	h_{ef}	$\delta N / N$	δN_0	δN_{∞}	$\delta V / V$	δV_0	δV_{∞}
	[mm]	[mm/kN]	[mm]	[mm]	[mm/kN]	[mm]	[mm]
M8 – M12 / IG-M6 – M10	all	0,13	$0,13 \cdot N_{Rk} / 3,5$	$2 \cdot \delta N_0$	0,55	$0,55 \cdot V_{Rk} / 3,5$	$1,5 \cdot \delta V_0$
M16	all				0,31	$0,31 \cdot V_{Rk} / 3,5$	$1,5 \cdot \delta V_0$

Injection system TILCA TIM V+, TIM V+ Frost for masonry

Performances hollow clay brick T8 P with insulation
Group factors, characteristic Resistances and Displacements

Annex C 40

Brick type: Hollow clay brick Thermoplan MZ90-G with insulation

Table C135: Stone description

Brick type	Hollow clay brick Thermoplan MZ90-G	
Insulation material	Rock wool	
Density	ρ [kg/dm ³]	$\geq 0,68$
Normalised mean compressive strength	f_b [N/mm ²]	≥ 12
Conversion factor for lower compressive strengths	$(f_b / 12)^{0,5} \leq 1,0$	
Code	EN 771-1:2011+A1:2015	
Producer (Country)	e.g. Mein Ziegelhaus (DE)	
Brick dimensions	[mm]	248 x 365 x 249
Drilling method	Rotary drilling	

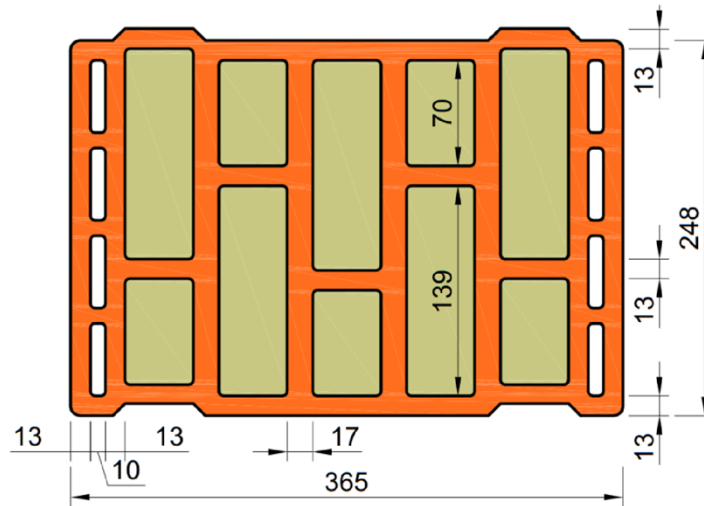


Table C136: Installation parameter

Anchor size		[-]	M8	M10	M12	M16	IG-M6	IG-M8	IG-M10
Installation torque	T_{inst}	[Nm]	≤ 4	≤ 4	≤ 10	≤ 10	≤ 4	≤ 4	≤ 4
Char. Edge distance	c_{cr}	[mm]	120 (for shear loads perpendicular to the free edge: $c_{cr} = 250$)						
Minimum Edge Distance	c_{min}	[mm]	50						
Characteristic Spacing	$s_{cr, II}$	[mm]	250						
	$s_{cr, \perp}$	[mm]	250						
Minimum Spacing	$s_{min, II}$, $s_{min, \perp}$	[mm]	50						

Table C137: Reduction factors for single anchors at the edge

Tension load			Shear load					
			Perpendicular to the free edge			Parallel to the free edge		
	with $c \geq$	$\alpha_{edge, N}$		with $c \geq$	$\alpha_{edge, V \perp}$		with $c \geq$	$\alpha_{edge, V II}$
	50	1,00		50	0,25		50	1,00
	120	1,00		250	1,00		120	1,00

Injection system TILCA TIM V+, TIM V+ Frost for masonry

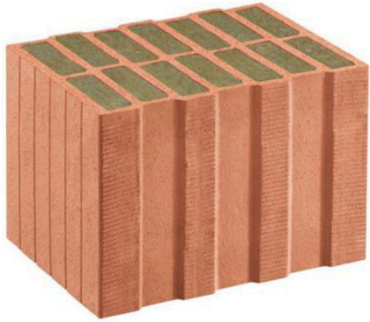
Performances hollow clay brick Thermoplan MZ90-G with insulation
Description of the stone, Installation parameters, Reductionfactors

Annex C 41

Brick type: Hollow clay brick Thermoplan MZ90-G with insulation										
Table C138: Factors for anchor groups under tension load										
Anchor position parallel to hor. joint					Anchor position perpendicular to hor. joint					
	with $c \geq$	with $s \geq$	$\alpha_{g II, N}$			with $c \geq$	with $s \geq$	$\alpha_{g \perp, N}$		
	50	50	1,00			50	50	1,00		
	120	250	2,00			120	250	2,00		
Table C139: Factors for anchor groups under shear load										
Anchor position parallel to hor. joint					Anchor position perpendicular to hor. joint					
Shear load perpendicular to the free edge		with $c \geq$	with $s \geq$	$\alpha_{g II, V \perp}$			with $c \geq$	with $s \geq$	$\alpha_{g \perp, V \perp}$	
		50	50	0,75			50	50	0,50	
		250	50	2,00			250	50	1,70	
Shear load parallel to the free edge		with $c \geq$	with $s \geq$	$\alpha_{g II, V II}$			with $c \geq$	with $s \geq$	$\alpha_{g \perp, V II}$	
		50	50	1,65			50	50	1,15	
		120	250	2,00			120	250	2,00	
Table C140: Characteristic values of tension and shear load resistances										
Anchor size	Perforated sleeve	Effective Anchorage depth	Characteristic Resistances with $c \geq c_{cr}$ and $s \geq s_{cr}$							All temperature ranges
			Use condition							
			d/d			w/d			d/d	
			w/w			w/w			w/w	
			40°C/24°C	80°C/50°C	120°C/72°C	40°C/24°C	80°C/50°C	120°C/72°C		
h_{ef}	$N_{Rk,b} = N_{Rk,p}^{2)}$			$N_{Rk,b} = N_{Rk,p}^{2)}$			$V_{Rk,b}^{2)}$			
[mm]	[kN]									
Normalised mean compressive strength $f_b \geq 12 \text{ N/mm}^2$ 1)										
M8	SH 12	80								
M8 / M10 / IG-M6	SH 16	≥ 85	3,0	3,0	2,5	3,0	3,0	2,5	4,0	
M12 / IG-M8	SH 20	≥ 85								
M16 / IG-M10	SH 20	≥ 85	3,5	3,5	3,0	3,5	3,5	3,0	7,5	
1) For lower compressive strengths resistances must be multiplied by the conversion factor according to Table C135. For stones with higher strengths, the shown values are valid without conversion.										
2) $N_{Rk,b,c} = N_{Rk,p,c}$ and $V_{Rk,c II} = V_{Rk,c \perp}$ according to Annex C 3										
Table C141: Displacements										
Anchor size	h_{ef}	$\delta N / N$	δN_0	δN_{∞}	$\delta V / V$	δV_0	δV_{∞}			
	[mm]	[mm/kN]	[mm]	[mm]	[mm/kN]	[mm]	[mm]			
M8 – M12 / IG-M6 – M10	all	0,13	$0,13 \cdot N_{Rk} / 3,5$	$2 \cdot \delta N_0$	0,55	$0,55 \cdot V_{Rk} / 3,5$	$1,5 \cdot \delta V_0$			
M16	all				0,31	$0,31 \cdot V_{Rk} / 3,5$	$1,5 \cdot \delta V_0$			
Injection system TILCA TIM V+, TIM V+ Frost for masonry							Annex C 42			
Performances hollow clay brick Thermoplan MZ90-G with insulation Group factors, characteristic Resistances and Displacements										

Brick type: Hollow clay brick Poroton FZ7,5 with insulation

Table C142: Stone description

Brick type	Hollow clay brick Poroton FZ7,5		
Insulation material	Rock wool		
Density	ρ [kg/dm ³]	$\geq 0,70$	
Normalised mean compressive strength	f_b [N/mm ²]	≥ 8	
Conversion factor for lower compressive strengths	$(f_b / 8)^{0,5} \leq 1,0$		
Code	EN 771-1:2011+A1:2015		
Producer (Country)	e.g. Schlagmann (DE)		
Brick dimensions	[mm]	248 x 365 x 249	
Drilling method	Rotary drilling		

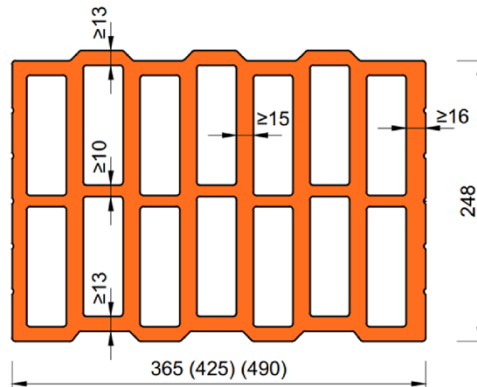


Table C143: Installation parameter

Anchor size		[-]	M8	M10	M12	M16	IG-M6	IG-M8	IG-M10
Installation torque	T_{inst}	[Nm]	≤ 5	≤ 5	≤ 10	≤ 10	≤ 5	≤ 5	≤ 5
Char. Edge distance (under fire conditions)	$c_{cr}, (c_{cr,fi})$	[mm]	120 (2 h_{ef}) (for shear loads perpendicular to the free edge: $c_{cr} = 250$)						
Minimum Edge Distance	c_{min}	[mm]	50						
Characteristic Spacing (under fire conditions)	$s_{cr, II}, (s_{cr,fi, II})$	[mm]	250 (4 h_{ef})						
	$s_{cr, \perp}, (s_{cr,fi, \perp})$	[mm]	250 (4 h_{ef})						
Minimum Spacing	$s_{min, II}, s_{min, \perp}$	[mm]	50						

Table C144: Reduction factors for single anchors at the edge

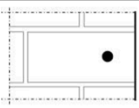
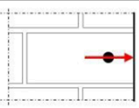
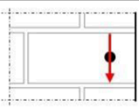
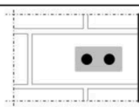
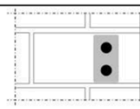
Tension load			Shear load					
			Perpendicular to the free edge			Parallel to the free edge		
	with $c \geq$	$\alpha_{edge, N}$		with $c \geq$	$\alpha_{edge, V \perp}$		with $c \geq$	$\alpha_{edge, V \parallel}$
	50	1,00		50	0,35		50	1,00
	120	1,00		250	1,00		120	1,00

Table C145: Factors for anchor groups under tension load

Anchor position parallel to hor. joint				Anchor position perpendicular to hor. joint			
	with $c \geq$	with $s \geq$	$\alpha_{g II, N}$		with $c \geq$	with $s \geq$	$\alpha_{g \perp, N}$
	50	50	1,40		50	50	1,15
	120	250	2,00		120	250	2,00

Injection system TILCA TIM V+, TIM V+ Frost for masonry

Performances hollow clay brick Poroton FZ7,5 with insulation
Description of the stone, Installation parameters, Reductionfactors

Annex C 43

Brick type: Hollow clay brick Poroton FZ7,5 with insulation

Table C146: Factors for anchor groups under shear load

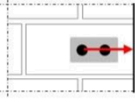
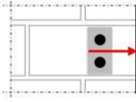
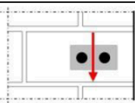
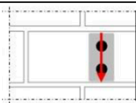
	Anchor position parallel to hor. joint				Anchor position perpendicular to hor. joint			
		with $c \geq$	with $s \geq$	$\alpha_{g II, V \perp}$		with $c \geq$	with $s \geq$	$\alpha_{g \perp, V \perp}$
Shear load perpendicular to the free edge		50	50	0,60		50	50	0,40
		250	50	1,55		250	50	1,00
		250	250	2,00		250	250	2,00
Shear load parallel to the free edge		with $c \geq$	with $s \geq$	$\alpha_{g II, V \parallel}$		with $c \geq$	with $s \geq$	$\alpha_{g \perp, V \parallel}$
		50	50	2,00		50	50	1,20
		120	250	2,00		120	250	2,00

Table C147: Characteristic values of tension and shear load resistances

Anchor size	Perforated sleeve	Effective Anchorage depth	Characteristic Resistances with $c \geq c_{cr}$ and $s \geq s_{cr}$					
			Use condition					
			d/d			w/d w/w		d/d w/d w/w
			40°C/24°C	80°C/50°C	120°C/72°C	40°C/24°C	80°C/50°C	120°C/72°C
		h_{ef}	$N_{Rk,b} = N_{Rk,p}^{2)}$			$N_{Rk,b} = N_{Rk,p}^{2)}$		$V_{Rk,b}^{2)}$
		[mm]	[kN]					

Normalised mean compressive strength $f_b \geq 8 \text{ N/mm}^2$ 1)

M8	SH 12	80							
M8 / M10/ IG-M6	SH 16	≥ 85	2,0	2,0	1,5	2,0	2,0	1,5	3,0
M12 / IG-M8	SH 20	≥ 85							4,5
M16 / IG-M10	SH 20	≥ 85							

1) For lower compressive strengths resistances must be multiplied by the conversion factor according to Table C142. For stones with higher strengths, the shown values are valid without conversion.

2) $N_{Rk,b,c} = N_{Rk,p,c}$ and $V_{Rk,c \parallel} = V_{Rk,c \perp}$ according to Annex C 3

Table C148: Displacements

Anchor size	h_{ef}	$\delta N / N$	δN_0	δN_{∞}	$\delta V / V$	δV_0	δV_{∞}
	[mm]	[mm/kN]	[mm]	[mm]	[mm/kN]	[mm]	[mm]
M8 – M12 / IG-M6 – M10	all	0,13	0,13 * $N_{Rk} / 3,5$	2 * δN_0	0,55	0,55 * $V_{Rk} / 3,5$	1,5 * δV_0
M16	all				0,31	0,31 * $V_{Rk} / 3,5$	1,5 * δV_0

Table C149: Characteristic values of tension and shear load resistances under fire exposure

Anchor size	Perforated sleeve	Effective Anchorage depth	Characteristic Resistances			
		h_{ef}	$N_{Rk,b,fi} = N_{Rk,p,fi} = V_{Rk,b,fi}$			
		[mm]	R30	R60	R90	R120
M8 / M10 / IG-M6	SH 16	130	0,64	0,37	0,11	-1)
M12 / M16 / IG-M8 IG-M10	SH 20	≥ 130				

1) no performance assessed

Injection system TILCA TIM V+, TIM V+ Frost for masonry	Annex C 44
Performances hollow clay brick Poroton FZ7,5 with insulation Group factors, characteristic Resistances and Displacements	

Brick type: Hollow clay brick Poroton FZ9 with insulation

Table C154: Factors for anchor groups under shear load

	Anchor position parallel to hor. joint				Anchor position perpendicular to hor. joint			
		with $c \geq$	with $s \geq$	$\alpha_{g II, V \perp}$		with $c \geq$	with $s \geq$	$\alpha_{g \perp, V \perp}$
Shear load perpendicular to the free edge		50	50	0,60		50	50	0,40
		250	50	1,55		250	50	1,00
		250	250	2,00		250	250	2,00
Shear load parallel to the free edge		with $c \geq$	with $s \geq$	$\alpha_{g II, V \parallel}$		with $c \geq$	with $s \geq$	$\alpha_{g \perp, V \parallel}$
		50	50	2,00		50	50	1,20
		120	250	2,00		120	250	2,00

Table C155: Characteristic values of tension and shear load resistances

Anchor size	Perforated sleeve	Effective Anchorage depth	Characteristic Resistances with $c \geq c_{cr}$ and $s \geq s_{cr}$						
			Use condition						
			d/d			w/d w/w			d/d w/d w/w
			40°C/24°C	80°C/50°C	120°C/72°C	40°C/24°C	80°C/50°C	120°C/72°C	All temperature ranges
		h_{ef}	$N_{Rk,b} = N_{Rk,p}^{2)}$			$N_{Rk,b} = N_{Rk,p}^{2)}$			$V_{Rk,b}^{2)}$
		[mm]	[kN]						
Normalised mean compressive strength $f_b \geq 10 \text{ N/mm}^2$ 1)									
M8	SH 12	80	2,0	2,0	1,5	2,0	2,0	1,5	3,0
M8 / M10 / IG-M6	SH 16	≥ 85							
M12 / IG-M8	SH 20	≥ 85							
M16 / IG-M10	SH 20	≥ 85							

1) For lower compressive strengths resistances must be multiplied by the conversion factor according to Table C150. For stones with higher strengths, the shown values are valid without conversion.

2) $N_{Rk,b,c} = N_{Rk,p,c}$ and $V_{Rk,c \parallel} = V_{Rk,c \perp}$ according to Annex C 3

Table C156: Displacements

Anchor size	h_{ef}	$\delta N / N$	δN_0	δN_{∞}	$\delta V / V$	δV_0	δV_{∞}
	[mm]	[mm/kN]	[mm]	[mm]	[mm/kN]	[mm]	[mm]
M8 – M12 / IG-M6 – M10	all	0,13	0,13 * $N_{Rk} / 3,5$	2 * δN_0	0,55	0,55 * $V_{Rk} / 3,5$	1,5 * δV_0
M16	all				0,31	0,31 * $V_{Rk} / 3,5$	1,5 * δV_0

Table C157: Characteristic values of tension and shear load resistances under fire exposure

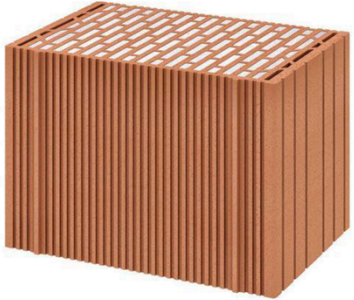
Anchor size	Perforated sleeve	Effective Anchorage depth	Characteristic Resistances			
			$N_{Rk,b,fi} = N_{Rk,p,fi} = V_{Rk,b,fi}$			
		h_{ef}	R30	R60	R90	R120
		[mm]	[kN]			
M8 / M10 / IG-M6	SH 16	130	0,64	0,37	0,11	-1)
M12 / M16 / IG-M8 IG-M10	SH 20	≥ 130				

1) no performance assessed

Injection system TILCA TIM V+, TIM V+ Frost for masonry	Annex C 46
Performances hollow clay brick Poroton FZ9 with insulation Group factors, characteristic Resistances and Displacements	

Brick type: Hollow clay brick Poroton S9 with insulation

Table C158: Stone description

Brick type	Hollow clay brick Poroton S9		
Insulationmaterial	Perlite		
Density	ρ [kg/dm ³]	$\geq 0,85$	
Normalised mean compressive strenght	f_b [N/mm ²]	≥ 12	
Conversion factor for lower compressive strenghts	$(f_b / 12)^{0,5} \leq 1,0$		
Code	EN 771-1:2011+A1:2015		
Producer (Country)	e.g. Schlagmann (DE)		
Brick dimensions	[mm]	248 x 365 x 249	
Drilling method	Rotary drilling		

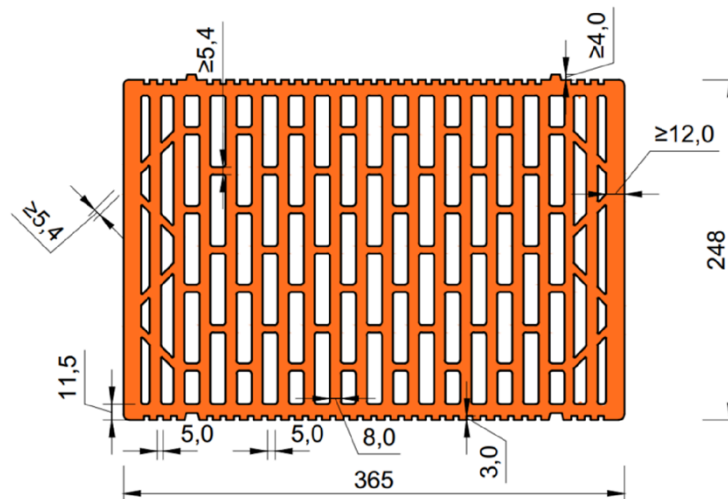
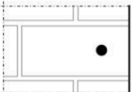
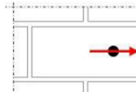



Table C159: Installation parameter

Anchor size		[-]	M8	M10	M12	M16	IG-M6	IG-M8	IG-M10
Installation torque	T_{inst}	[Nm]	≤ 5	≤ 5	≤ 10	≤ 10	≤ 5	≤ 5	≤ 5
Char. Edge distance	c_{cr}	[mm]	120 (for shear loads perpendicular to the free edge: $c_{cr} = 250$)						
Minimum Edge Distance	c_{min}	[mm]	50						
Characteristic Spacing	$s_{cr, II}$	[mm]	250						
	$s_{cr, \perp}$	[mm]	250						
Minimum Spacing	$s_{min, II}$, $s_{min, \perp}$	[mm]	50						

Table C160: Reduction factors for single anchors at the edge

Tension load			Shear load					
			Perpendicular to the free edge			Parallel to the free edge		
	with $c \geq$	$\alpha_{edge, N}$		with $c \geq$	$\alpha_{edge, V \perp}$		with $c \geq$	$\alpha_{edge, V II}$
	50	1,00		50	0,30		50	1,00
	120	1,00		250	1,00		120	1,00

Injection system TILCA TIM V+, TIM V+ Frost for masonry

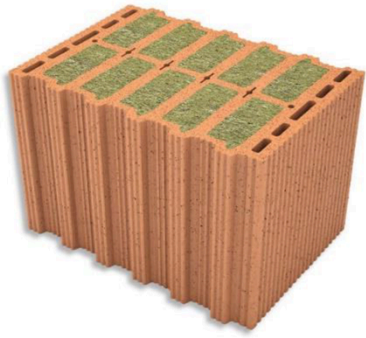
Performances hollow clay brick Poroton S9 with insulation
Description of the stone, Installation parameters, Reductionfactors

Annex C 47

Brick type: Hollow clay brick Poroton S9 with insulation										
Table C161: Factors for anchor groups under tension load										
Anchor position parallel to hor. joint					Anchor position perpendicular to hor. joint					
	with $c \geq$	with $s \geq$	$\alpha_{g II, N}$			with $c \geq$	with $s \geq$	$\alpha_{g \perp, N}$		
	50	50	1,50			50	50	1,00		
	120	250	2,00			120	250	2,00		
Table C162: Factors for anchor groups under shear load										
Anchor position parallel to hor. joint					Anchor position perpendicular to hor. joint					
Shear load perpendicular to the free edge		with $c \geq$	with $s \geq$	$\alpha_{g II, V \perp}$			with $c \geq$	with $s \geq$	$\alpha_{g \perp, V \perp}$	
		50	50	0,40			50	50	0,40	
		250	50	1,00			250	50	1,20	
		250	250	2,00		250	250	2,00		
Shear load parallel to the free edge		with $c \geq$	with $s \geq$	$\alpha_{g II, V II}$			with $c \geq$	with $s \geq$	$\alpha_{g \perp, V II}$	
		50	50	1,65			50	50	1,00	
		120	250	2,00			120	250	2,00	
Table C163: Characteristic values of tension and shear load resistances										
Anchor size	Perforated sleeve	Effective Anchorage depth	Characteristic Resistances with $c \geq c_{cr}$ and $s \geq s_{cr}$							All temperature ranges
			Use condition							
			d/d			w/d w/w			d/d w/d w/w	
			40°C/24°C	80°C/50°C	120°C/72°C	40°C/24°C	80°C/50°C	120°C/72°C		
			$N_{Rk,b} = N_{Rk,p}^{2)}$			$N_{Rk,b} = N_{Rk,p}^{2)}$			$V_{Rk,b}^{2)}$	
h_{ef}										
[mm]							[kN]			
Normalised mean compressive strength $f_b \geq 12 \text{ N/mm}^2$ 1)										
M8	SH 12	80								
M8 / M10 / IG-M6	SH 16	≥ 85	1,5	1,5	1,5	1,5	1,5	1,5	5,0	
M12 / M16 / IG-M8 / IG-M10	SH 20	≥ 85								
1) For lower compressive strengths resistances must be multiplied by the conversion factor according to Table C158. For stones with higher strengths, the shown values are valid without conversion.										
2) $N_{Rk,b,c} = N_{Rk,p,c}$ and $V_{Rk,c II} = V_{Rk,c \perp}$ according to Annex C 3										
Table C164: Displacements										
Anchor size	h_{ef}	$\delta N / N$	δN_0	δN_{∞}	$\delta V / V$	δV_0	δV_{∞}			
	[mm]	[mm/kN]	[mm]	[mm]	[mm/kN]	[mm]	[mm]			
M8 – M12 / IG-M6 – M10	all	0,13	0,13*N _{Rk} / 3,5	2* δN_0	0,55	0,55*V _{Rk} / 3,5	1,5* δV_0			
M16	all				0,31	0,31*V _{Rk} / 3,5	1,5* δV_0			
Injection system TILCA TIM V+, TIM V+ Frost for masonry							Annex C 48			
Performances hollow clay brick Poroton S9 with insulation Group factors, characteristic Resistances and Displacements										

Brick type: Hollow clay brick Thermopor TV8+ with insulation

Table C165: Stone description

Brick type	Hollow clay brick Thermopor TV8+		
Insulation material	Rock wool		
Density	ρ [kg/dm ³]	$\geq 0,70$	
Normalised mean compressive strength	f_b [N/mm ²]	≥ 10	
Conversion factor for lower compressive strengths	$(f_b / 10)^{0,5} \leq 1,0$		
Code	EN 771-1:2011+A1:2015		
Producer (Country)	e.g. THERMOPOR GmbH (DE)		
Brick dimensions	[mm]	248 x 365 x 249	
Drilling method	Rotary drilling		

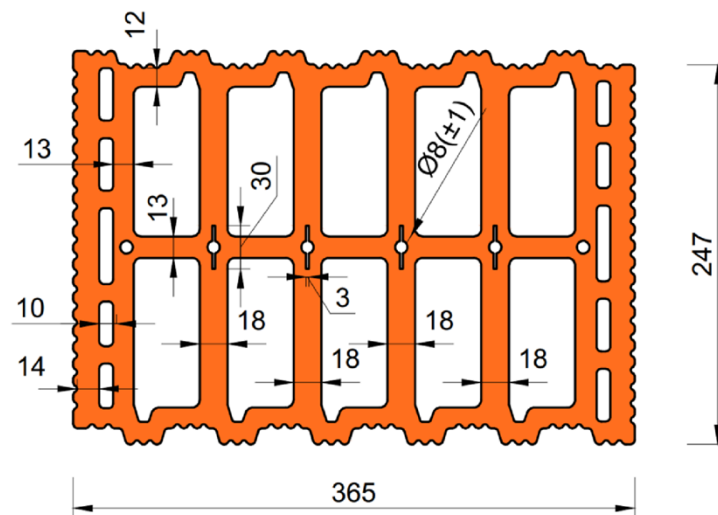
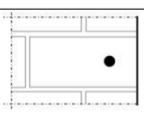
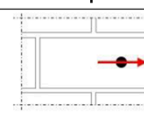
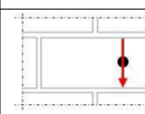


Table C166: Installation parameter

Anchor size		[-]	M8	M10	M12	M16	IG-M6	IG-M8	IG-M10
Installation torque	T_{inst}	[Nm]	≤ 4	≤ 4	≤ 10	≤ 10	≤ 4	≤ 4	≤ 4
Char. Edge distance	c_{cr}	[mm]	120 (for shear loads perpendicular to the free edge: $c_{cr} = 250$)						
Minimum Edge Distance	c_{min}	[mm]	50						
Characteristic Spacing	$s_{cr, II}$	[mm]	250						
	$s_{cr, \perp}$	[mm]	250						
Minimum Spacing	$s_{min, II}$ $s_{min, \perp}$	[mm]	50						

Table C167: Reduction factors for single anchors at the edge

Tension load			Shear load					
			Perpendicular to the free edge			Parallel to the free edge		
	with $c \geq$	$\alpha_{edge, N}$		with $c \geq$	$\alpha_{edge, V \perp}$		with $c \geq$	$\alpha_{edge, V II}$
	50	1,00		50	0,25		50	1,00
	120	1,00		250	1,00		120	1,00

Injection system TILCA TIM V+, TIM V+ Frost for masonry

Performances hollow clay brick Thermopor TV8+ with insulation
Description of the stone, Installation parameters, Reductionfactors

Annex C 49

Brick type: Hollow clay brick Thermopor TV8+ with insulation

Table C168: Factors for anchor groups under tension load

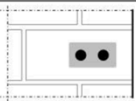
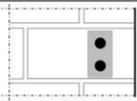
Anchor position parallel to hor. joint				Anchor position perpendicular to hor. joint			
	with $c \geq$	with $s \geq$	$\alpha_{g II, N}$		with $c \geq$	with $s \geq$	$\alpha_{g \perp, N}$
	50	50	1,00		50	50	1,00
	120	250	2,00		120	250	2,00

Table C169: Factors for anchor groups under shear load

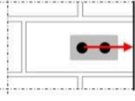
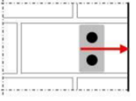
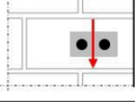
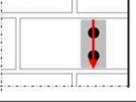
	Anchor position parallel to hor. joint				Anchor position perpendicular to hor. joint			
		with $c \geq$	with $s \geq$	$\alpha_{g II, V \perp}$		with $c \geq$	with $s \geq$	$\alpha_{g \perp, V \perp}$
Shear load perpendicular to the free edge		50	50	0,75		50	50	0,50
		250	50	2,00		250	50	1,70
	250	250	2,00	250	250	2,00		
Shear load parallel to the free edge		with $c \geq$	with $s \geq$	$\alpha_{g II, V \parallel}$		with $c \geq$	with $s \geq$	$\alpha_{g \perp, V \parallel}$
		50	50	1,65		50	50	1,15
		120	250	2,00		120	250	2,00

Table C170: Characteristic values of tension and shear load resistances

Anchor size	Perforated sleeve	Effective Anchorage depth	Characteristic Resistances with $c \geq c_{cr}$ and $s \geq s_{cr}$							
			Use condition							
			d/d			w/d			d/d	
			w/w			w/w			w/w	
			40°C/24°C	80°C/50°C	120°C/72°C	40°C/24°C	80°C/50°C	120°C/72°C	All temperature ranges	
h_{ef}	$N_{Rk,b} = N_{Rk,p}^{2)}$			$N_{Rk,b} = N_{Rk,p}^{2)}$			$V_{Rk,b}^{2)}$			
[mm]	[kN]									

Normalised mean compressive strength $f_b \geq 10 \text{ N/mm}^2$ 1)

Anchor size	SH	Effective Anchorage depth	40°C/24°C	80°C/50°C	120°C/72°C	40°C/24°C	80°C/50°C	120°C/72°C	All temperature ranges
M8	SH 12	80							
M8 / M10 / IG-M6	SH 16	≥ 85	3,0	3,0	2,5	3,0	3,0	2,5	3,5
M12 / IG-M8	SH 20	≥ 85							
M16 / IG-M10	SH 20	≥ 85	3,5	3,5	3,0	3,5	3,5	3,0	7,0

1) For lower compressive strengths resistances must be multiplied by the conversion factor according to Table C165. For stones with higher strengths, the shown values are valid without conversion.

2) $N_{Rk,b,c} = N_{Rk,p,c}$ and $V_{Rk,c \parallel} = V_{Rk,c \perp}$ according to Annex C 3

Table C171: Displacements

Anchor size	h_{ef}	$\delta N / N$	δN_0	δN_{∞}	$\delta V / V$	δV_0	δV_{∞}
	[mm]	[mm/kN]	[mm]	[mm]	[mm/kN]	[mm]	[mm]
M8 – M12 / IG-M6 – M10	all	0,13	$0,13 \cdot N_{Rk} / 3,5$	$2 \cdot \delta N_0$	0,55	$0,55 \cdot V_{Rk} / 3,5$	$1,5 \cdot \delta V_0$
M16	all				0,31	$0,31 \cdot V_{Rk} / 3,5$	$1,5 \cdot \delta V_0$

Injection system TILCA TIM V+, TIM V+ Frost for masonry

Performances hollow clay brick Thermopor TV8+ with insulation
Group factors, characteristic Resistances and Displacements

Annex C 50

Brick type: Hollow light weight concrete brick HBL 16DF

Table C172: Stone description

Brick type	Hollow light weight concrete brick HBL 16DF	
Density	ρ [kg/dm ³]	$\geq 1,0$
Normalised mean compressive strenght	f_b [N/mm ²]	$\geq 3,1$
Conversion factor for lower compressive strengths	$(f_b / 3,1)^{0,5} \leq 1,0$	
Code	EN 771-3:2011+A1:2015	
Producer (Country)	e.g. KLB Klimaleichtblock (DE)	
Brick dimensions	[mm]	500 x 250 x 240
Drilling method	Rotary drilling	

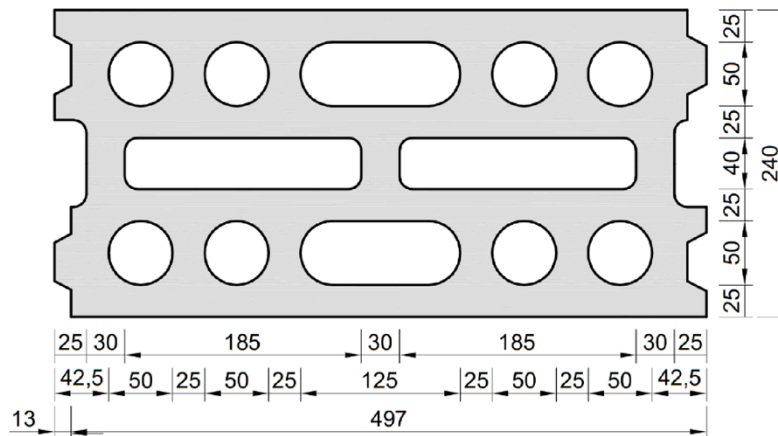


Table C173: Installation parameter

Anchor size	[-]	M8	M10	M12	M16	IG-M6	IG-M8	IG-M10
Installation torque	T_{inst} [Nm]	≤ 2	≤ 2	≤ 5	≤ 5	≤ 2	≤ 5	≤ 5
Char. Edge distance (under fire conditions)	$C_{cr}, (C_{cr,fi})$ [mm]	120 (2 h_{ef}) (for shear loads perpendicular to the free edge: $C_{cr} = 250$)						
Minimum Edge Distance	C_{min} [mm]	50						
Characteristic Spacing (under fire conditions)	$S_{cr, II}; (S_{cr,fi, II})$ [mm]	500 (4 h_{ef})						
	$S_{cr, \perp}; (S_{cr,fi, \perp})$ [mm]	250 (4 h_{ef})						
Minimum Spacing	$S_{min, II}; S_{min, \perp}$ [mm]	50						

Table C174: Reduction factors for single anchors at the edge

Tension load			Shear load					
			Perpendicular to the free edge			Parallel to the free edge		
	with $c \geq 50$	$\alpha_{edge, N}$		with $c \geq 50$	$\alpha_{edge, V \perp}$		with $c \geq 50$	$\alpha_{edge, V \parallel}$
	120	1,00		250	1,00		120	1,00

Table C175: Factors for anchor groups under tension load

Anchor position parallel to hor. joint				Anchor position perpendicular to hor. joint			
	with $c \geq 50$	with $s \geq 50$	$\alpha_{g \parallel, N}$		with $c \geq 50$	with $s \geq 50$	$\alpha_{g \perp, N}$
	120	500	2,00		120	250	2,00

Injection system TILCA TIM V+, TIM V+ Frost for masonry

Performances hollow light weight concrete brick HBL 16DF
Description of the stone, Installation parameters, Reductionfactors

Annex C 51

Brick type: Hollow light weight concrete brick HBL 16DF

Table C176: Factors for anchor groups under shear load

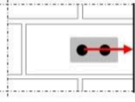
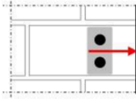
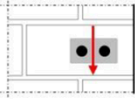
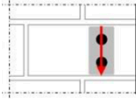
	Anchor position parallel to hor. joint				Anchor position perpendicular to hor. joint			
		with $c \geq$	with $s \geq$	$\alpha_{g II, V \perp}$		with $c \geq$	with $s \geq$	$\alpha_{g \perp, V \perp}$
Shear load perpendicular to the free edge		50	50	0,60		50	50	0,35
		120	50	2,00		120	50	1,15
		120	500	2,00		120	250	2,00
Shear load parallel to the free edge		with $c \geq$	with $s \geq$	$\alpha_{g II, V II}$		with $c \geq$	with $s \geq$	$\alpha_{g \perp, V II}$
		50	50	1,30		50	50	1,00
		120	250	2,00		120	250	2,00

Table C177: Characteristic values of tension and shear load resistances

Anchor size	Perforated sleeve	Effective Anchorage depth	Characteristic Resistances with $c \geq c_{cr}$ and $s \geq s_{cr}$						
			Use condition						
			d/d			w/d w/w			d/d w/d w/w
			40°C/24°C	80°C/50°C	120°C/72°C	40°C/24°C	80°C/50°C	120°C/72°C	All temperature ranges
		h_{ef}	$N_{Rk,b} = N_{Rk,p}^{2)}$			$N_{Rk,b} = N_{Rk,p}^{2)}$			$V_{Rk,b}^{2)}$
		[mm]	[kN]						
Normalised mean compressive strength $f_b \geq 3,1 \text{ N/mm}^2$ 1)									
M8 / M10/ IG-M6	SH 16	≥ 85	1,2	1,2	0,9	1,2	1,2	0,9	2,0
M12 / IG-M8	SH 20	≥ 85	1,5	1,5	1,2	1,5	1,5	1,2	3,0
M16 / IG-M10	SH 20	≥ 85							5,0

1) For lower compressive strengths resistances must be multiplied by the conversion factor according to Table C172. For stones with higher strengths, the shown values are valid without conversion.

2) $N_{Rk,b,c} = N_{Rk,p,c}$ and $V_{Rk,c II} = V_{Rk,c \perp}$ according to Annex C 3

Table C178: Displacements

Anchor size	h_{ef}	$\delta N / N$	δN_0	δN_{∞}	$\delta V / V$	δV_0	δV_{∞}
	[mm]	[mm/kN]	[mm]	[mm]	[mm/kN]	[mm]	[mm]
M8 – M12 / IG-M6 – M10	all	0,13	0,13 * $N_{Rk} / 3,5$	2 * δN_0	0,55	0,55 * $V_{Rk} / 3,5$	1,5 * δV_0
M16	all				0,31	0,31 * $V_{Rk} / 3,5$	1,5 * δV_0

Table C179: Characteristic values of tension and shear load resistances under fire exposure

Anchor size	Perforated sleeve	Effective Anchorage depth	Characteristic Resistances			
		h_{ef}	$N_{Rk,b,fi} = N_{Rk,p,fi} = V_{Rk,b,fi}$			
		[mm]	R30	R60	R90	R120
M8 / M10 / IG-M6	SH 16	130	0,29	0,21	-1)	-1)
M12 / IG-M8	SH 20	≥ 130				
M16 / IG-M10	SH 20	≥ 130				

1) no performance assessed


Injection system TILCA TIM V+, TIM V+ Frost for masonry

Performances hollow light weight concrete brick HBL 16DF
Group factors, characteristic Resistances and Displacements

Annex C 52

Brick type: Hollow concrete brick Bloc Creux B40

Table C180: Stone description

Brick type	Hollow concrete brick Bloc Creux B40		
Density	ρ [kg/dm ³]	$\geq 0,8$	
Normalised mean compressive strength	f_b [N/mm ²]	$\geq 5,2$	
Conversion factor for lower compressive strengths	$(f_b / 5,2)^{0,5} \leq 1,0$		
Code	EN 772-1		
Producer (Country)	e.g. Leroux (FR)		
Brick dimensions	[mm]	500 x 200 x 200	
Drilling method	Rotary drilling		

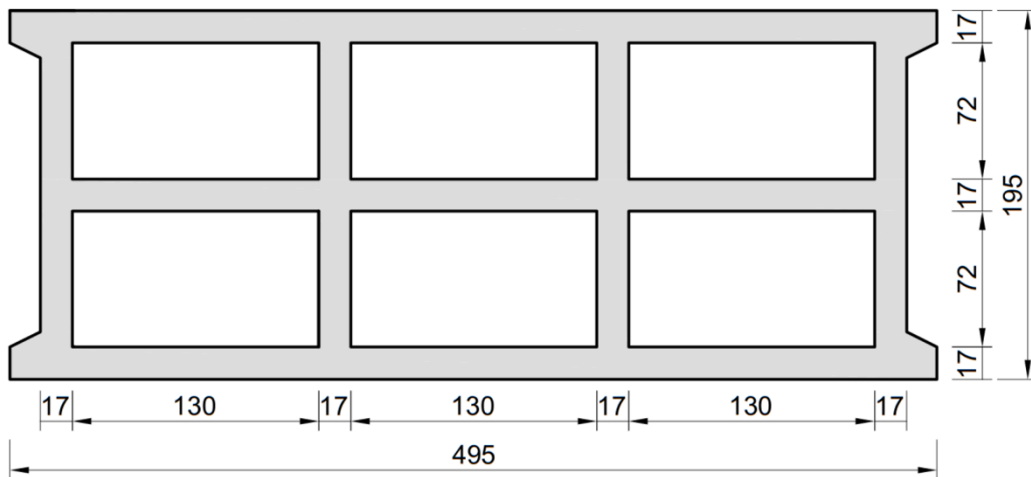
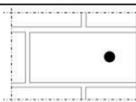
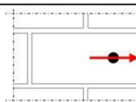
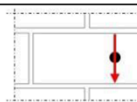


Table C181: Installation parameter

Anchor size		[-]	M8	M10	M12	M16	IG-M6	IG-M8	IG-M10
Installation torque	T_{inst}	[Nm]	≤ 4	≤ 4	≤ 4	≤ 4	≤ 4	≤ 4	≤ 4
Char. Edge distance	c_{cr}	[mm]	120 (for shear loads perpendicular to the free edge: $c_{cr} = 170$)						
Minimum Edge Distance	c_{min}	[mm]	50						
Characteristic Spacing	$s_{cr, II}$	[mm]	170						
	$s_{cr, \perp}$	[mm]	200						
Minimum Spacing	$s_{min, II}$ $s_{min, \perp}$	[mm]	50						

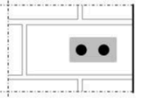
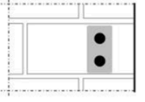
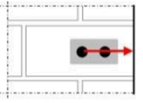
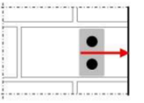
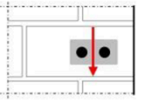
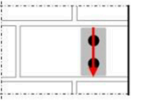
Table C182: Reduction factors for single anchors at the edge


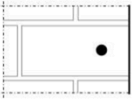
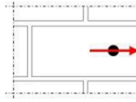
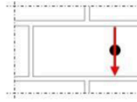
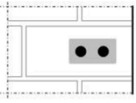
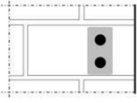
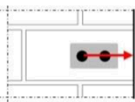
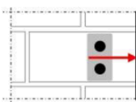
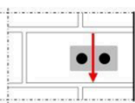
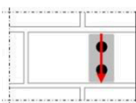
Tension load			Shear load					
			Perpendicular to the free edge			Parallel to the free edge		
	with $c \geq$	$\alpha_{edge, N}$		with $c \geq$	$\alpha_{edge, V \perp}$		with $c \geq$	$\alpha_{edge, V II}$
	50	1,00		50	0,35		50	1,00
	120	1,00		170	1,00		120	1,00

Injection system TILCA TIM V+, TIM V+ Frost for masonry

Performances hollow concrete brick Bloc Creux B40
Description of the stone, Installation parameters, Reductionfactors

Annex C 53

Brick type: Hollow concrete brick Bloc Creux B40										
Table C183: Factors for anchor groups under tension load										
Anchor position parallel to hor. joint					Anchor position perpendicular to hor. joint					
	with $c \geq$	with $s \geq$	$\alpha_{g II, N}$			with $c \geq$	with $s \geq$	$\alpha_{g \perp, N}$		
	50	50	1,50			50	50	1,40		
	50	170	2,00			50	200	2,00		
	120	170	2,00			120	200	2,00		
Table C184: Factors for anchor groups under shear load										
Anchor position parallel to hor. joint					Anchor position perpendicular to hor. joint					
Shear load perpendicular to the free edge		with $c \geq$	with $s \geq$	$\alpha_{g II, V \perp}$			with $c \geq$	with $s \geq$	$\alpha_{g \perp, V \perp}$	
		50	50	0,55			50	50	0,35	
		120	50	1,30			120	50	0,85	
		120	170	2,00			120	200	2,00	
Shear load parallel to the free edge		with $c \geq$	with $s \geq$	$\alpha_{g II, V \parallel}$			with $c \geq$	with $s \geq$	$\alpha_{g \perp, V \parallel}$	
		50	50	1,10			50	50	1,00	
		120	170	2,00			50	200	2,00	
		120	200	2,00			120	200	2,00	
Table C185: Characteristic values of tension and shear load resistances										
Anchor size	Perforated sleeve	Effective Anchorage depth	Characteristic Resistances with $c \geq c_{cr}$ and $s \geq s_{cr}$							
			Use condition							
			d/d			w/d w/w			d/d w/d w/w	
			40°C/24°C	80°C/50°C	120°C/72°C	40°C/24°C	80°C/50°C	120°C/72°C	All temperature ranges	
			h_{ef}	$N_{Rk,b} = N_{Rk,p}^{2)}$			$N_{Rk,b} = N_{Rk,p}^{2)}$			$V_{Rk,b}^{2)}$
[mm]	[kN]									
Normalised mean compressive strength $f_b \geq 5,2 \text{ N/mm}^2$ 1)										
M8 / M10 / IG-M6	SH 16	130	2,0	1,5	1,2	2,0	1,5	1,2	6,0	
M12 / M16 / IG-M8 / IG-M10	SH 20	≥ 130								
1) For lower compressive strengths resistances must be multiplied by the conversion factor according to Table C180. For stones with higher strengths, the shown values are valid without conversion.										
2) $N_{Rk,b,c} = N_{Rk,p,c}$ and $V_{Rk,c \parallel} = V_{Rk,c \perp}$ according to Annex C 3										
Table C186: Displacements										
Anchor size	h_{ef}	$\delta N / N$	δN_0	δN_{∞}	$\delta V / V$	δV_0	δV_{∞}			
	[mm]	[mm/kN]	[mm]	[mm]	[mm/kN]	[mm]	[mm]			
M8 – M12 / IG-M6 – M10	all	0,13	$0,13 \cdot N_{Rk} / 3,5$	$2 \cdot \delta N_0$	0,55	$0,55 \cdot V_{Rk} / 3,5$	$1,5 \cdot \delta V_0$			
M16	all				0,31	$0,31 \cdot V_{Rk} / 3,5$	$1,5 \cdot \delta V_0$			
Injection system TILCA TIM V+, TIM V+ Frost for masonry							Annex C 54			
Performances hollow concrete brick Bloc Creux B40 Group factors, characteristic Resistances and Displacements										

Brick type: Solid light weight concrete brick									
Table C187: Stone description									
Brick type	Solid light weight concrete brick								
Density	ρ [kg/dm ³]	$\geq 0,6$							
Normalised mean compressive strenght	f_b [N/mm ²]	≥ 2							
Conversion factor for lower compressive strengths	$(f_b / 2)^{0,5} \leq 1,0$								
Code	EN 771-3:2011+A1:2015								
Producer (Country)	e.g. Bisotherm (DE)								
Brick dimensions	[mm]	$\geq 240 \times 300 \times 113$							
Drilling method	Rotary drilling								
									
Table C188: Installation parameter									
Anchor size		[-]	M8	M10	M12	M16	IG-M6	IG-M8	IG-M10
Installation torque	T_{inst}	[Nm]	≤ 2	≤ 2	≤ 2	≤ 2	≤ 2	≤ 2	≤ 2
Char. Edge distance	c_{cr}	[mm]	150						
Minimum Edge Distance	c_{min}	[mm]	60						
Characteristic Spacing	$s_{cr, II}$	[mm]	300						
	$s_{cr, \perp}$	[mm]	300						
Minimum Spacing	$s_{min, II}; s_{min, \perp}$	[mm]	120						
Table C189: Reduction factors for single anchors at the edge									
Tension load			Shear load						
			Perpendicular to the free edge				Parallel to the free edge		
	with $c \geq$	$\alpha_{edge, N}$		with $c \geq$	$\alpha_{edge, V \perp}$		with $c \geq$	$\alpha_{edge, V II}$	
	60	1,00		60	0,25		60	0,40	
	150	1,00		150	1,00		100	1,00	
Table C190: Factors for anchor groups under tension load									
Anchor position parallel to hor. joint				Anchor position perpendicular to hor. joint					
	with $c \geq$	with $s \geq$	$\alpha_{g II, N}$		with $c \geq$	with $s \geq$	$\alpha_{g \perp, N}$		
	60	120	1,00		60	120	1,00		
	150	300	2,00		150	300	2,00		
Table C191: Factors for anchor groups under shear load									
Anchor position parallel to hor. joint				Anchor position perpendicular to hor. joint					
Shear load perpendicular to the free edge		with $c \geq$	with $s \geq$	$\alpha_{g II, V \perp}$		with $c \geq$	with $s \geq$	$\alpha_{g \perp, V \perp}$	
		60	120	0,25		60	120	0,25	
		150	120	1,00		150	120	1,00	
Shear load parallel to the free edge		with $c \geq$	with $s \geq$	$\alpha_{g II, V II}$		with $c \geq$	with $s \geq$	$\alpha_{g \perp, V II}$	
		60	120	0,40		60	120	0,40	
		100	120	1,00		100	120	1,00	
	150	300	2,00		150	300	2,00		
Injection system TILCA TIM V+, TIM V+ Frost for masonry									
Performances solid light weight concrete brick Description of the stone, Installation parameters, Reduction- and Group factors							Annex C 55		

Brick type: Solid light weight concrete brick									
Table C192: Characteristic values of tension and shear load resistances									
Anchor size	Perforated sleeve	Effective Anchorage depth	Characteristic Resistances with $c \geq c_{cr}$ and $s \geq s_{cr}$					All temperature ranges	
			Use condition						
			d/d			w/d w/w			d/d w/d w/w
			40°C/24°C	80°C/50°C	120°C/72°C	40°C/24°C	80°C/50°C		120°C/72°C
h_{ef}	$N_{Rk,b} = N_{Rk,p}^{2)}$			$N_{Rk,b} = N_{Rk,p}^{2)}$		$V_{Rk,b}^{2)}$			
[mm]	[kN]								
Normalised mean compressive strength $f_b \geq 2 \text{ N/mm}^2$ 1)									
M8	-	80	3,0	2,5	2,0	2,5	2,0	1,5	3,0
M10 / IG-M6	-	90							
M12 / M16 / IG-M8 / IG-M10	-	100							
M8	SH 12	80	2,5	2,5	2,0	2,5	2,0	1,5	
M8 / M10/ IG-M6	SH 16	≥ 85							
M12 / M16 / IG-M8 / IG-M10	SH 20	≥ 85							
1) For lower compressive strengths resistances must be multiplied by the conversion factor according to Table C187. For stones with higher strengths, the shown values are valid without conversion.									
2) $N_{Rk,b,c} = N_{Rk,p,c}$ and $V_{Rk,c,II} = V_{Rk,c,I}$ according to Annex C 3									
Table C193: Displacements									
Anchor size	h_{ef}	δ_N / N	δ_{N0}	$\delta_{N\infty}$	δ_V / V	δ_{V0}	$\delta_{V\infty}$		
	[mm]	[mm/kN]	[mm]	[mm]	[mm/kN]	[mm]	[mm]		
M8 – M12 / IG-M6 – M10	all	0,1	0,1*N _{Rk} / 3,5	2*δ _{N0}	0,3	0,3*V _{Rk} / 3,5	1,5*δ _{V0}		
M16	all				0,1	0,1*V _{Rk} / 3,5	1,5*δ _{V0}		
Injection system TILCA TIM V+, TIM V+ Frost for masonry					Annex C 56				
Performances solid light weight concrete brick Characteristic Resistances and Displacements									