

Public-law institution jointly founded by the federal states and the Federation

European Technical Assessment Body
for construction products



European Technical Assessment

ETA-25/1106
of 23 January 2026

English translation prepared by DIBt - Original version in German language

General Part

Technical Assessment Body issuing the European Technical Assessment:

Deutsches Institut für Bautechnik

Trade name of the construction product

Rebar connection with Selkent
injection system SEL-EPA PLUS

Product family
to which the construction product belongs

Systems for post-installed
rebar connections with mortar

Manufacturer

Selkent Fastenings Ltd.
Osprey House
New Mill Road
BR5 3QJ ORPINGTON, LONDON
GROSSBRITANNIEN

Manufacturing plant

Werk Selkent

This European Technical Assessment
contains

27 pages including 3 annexes which form an integral part
of this assessment

This European Technical Assessment is
issued in accordance with Article 95(4) of
Regulation (EU) No 2024/3110, on the basis of

EAD 330087-01-0601

The European Technical Assessment is issued by the Technical Assessment Body in its official language. Translations of this European Technical Assessment in other languages shall fully correspond to the original issued document and shall be identified as such.

Communication of this European Technical Assessment, including transmission by electronic means, shall be in full. However, partial reproduction may only be made with the written consent of the issuing Technical Assessment Body. Any partial reproduction shall be identified as such.

This European Technical Assessment may be withdrawn by the issuing Technical Assessment Body, in particular pursuant to information by the Commission in accordance with Article 36(3) of Regulation (EU) No 2024/3110.

Specific Part

1 Technical description of the product

The subject of this European Technical Assessment is the post-installed connection, by anchoring or overlap connection joint, of reinforcing bars (rebars) in existing structures made of normal weight concrete, using the "Rebar connection with injection system Selkent SEL-EPA Plus" in accordance with the regulations for reinforced concrete construction.

Reinforcing bars made of steel with a diameter ϕ from 8 to 40 mm or the rebar anchor FRA or FRA HCR of sizes M12 to M24 according to Annex A and injection mortar Selkent SEL-EPA Plus or SEL-EPA Plus Low Speed are used for rebar connections. The rebar is placed into a drilled hole filled with injection mortar and is anchored via the bond between rebar, injection mortar and concrete.

The product description is given in Annex A.

2 Specification of the intended use in accordance with the applicable European assessment Document

The performances given in Section 3 are only valid if the rebar connection is used in compliance with the specifications and conditions given in Annex B.

The verifications and assessment methods on which this European Technical Assessment is based lead to the assumption of a working life of the rebar connections of at least 50 and/or 100 years. The indications given on the working life cannot be interpreted as a guarantee given by the producer, but are to be regarded only as a means for choosing the right products in relation to the expected economically reasonable working life of the works.

3 Performance of the product and references to the methods used for its assessment

3.1 Mechanical resistance and stability (BWR 1)

Essential characteristic	Performance
Characteristic resistance under static and quasi-static loading	See Annex C 1, C 2 and C 5
Characteristic resistance under seismic loading	See Annex B 5, C 3 and C 4

3.2 Safety in case of fire (BWR 2)

Essential characteristic	Performance
Reaction to fire	Class A1
Resistance to fire	See Annex C 5 and C 6

4 Assessment and verification of constancy of performance (AVCP) system applied, with reference to its legal base

In accordance with European Assessment Document EAD No. 330087-01-0601, the applicable European legal act is: [96/582/EC].

The system to be applied is: 1

5 Technical details necessary for the implementation of the AVCP system, as provided for in the applicable European Assessment Document

Technical details necessary for the implementation of the AVCP system are laid down in the control plan deposited with Deutsches Institut für Bautechnik.

Issued in Berlin on 23 January 2026 by Deutsches Institut für Bautechnik

Dipl.-Ing. Beatrix Wittstock
Head of Section

beglaubigt:
Baderschneider

Installation conditions and application examples reinforcing bars, part 1

Figure A1.1:

Overlap joint with existing reinforcement for rebar connections of slabs and beams

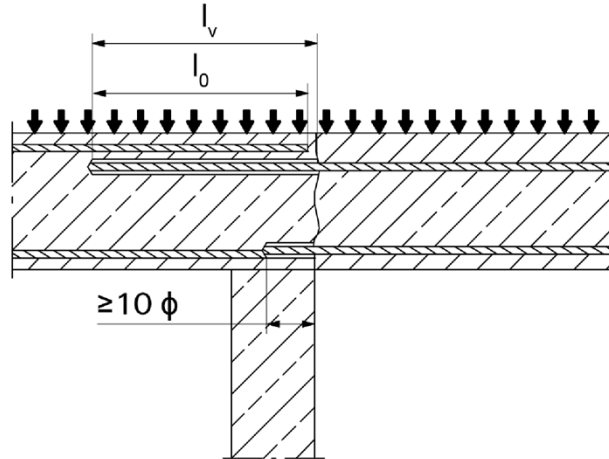

Figure A1.2:

Overlap joint with existing reinforcement at a foundation of a column or wall where the rebar is stressed

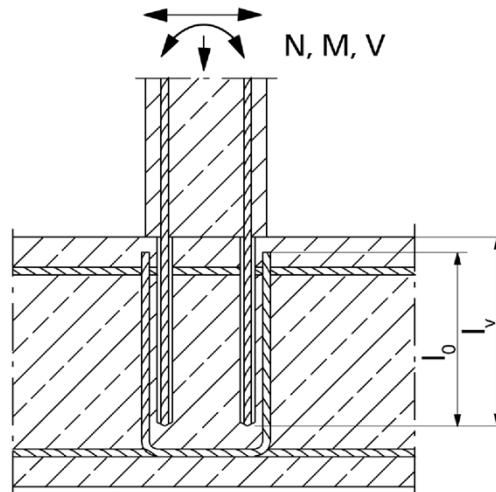
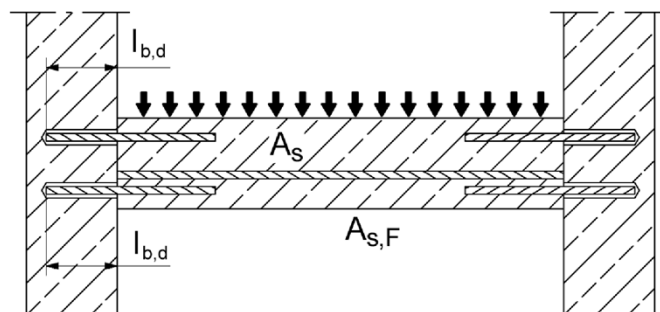

Figure A1.3:

End anchoring of slabs or beams (e.g. designed as simply supported)



Figures not to scale

Rebar connection with injection system Selkent SEL-EPA Plus

Product description

Installation conditions and application examples reinforcing bars, part 1

Annex A1

Installation conditions and application examples reinforcing bars, part 2

Figure A2.1:

Rebar connection for stressed primarily in compression

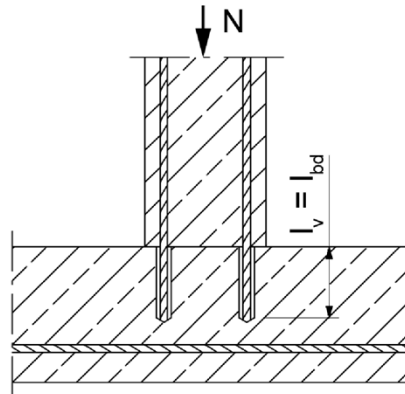
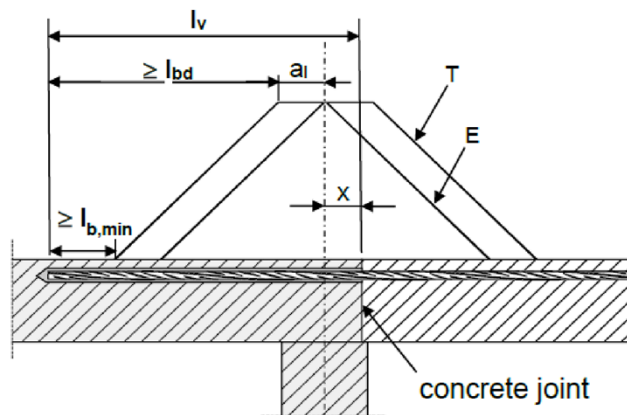

Figure A2.2:

Anchoring of reinforcement to cover the enveloped line of acting tensile force in the bending member



(only post-installed rebar is plotted)

Key to Figure

- T Acting tensile force
- E Envelope of $M_{ed} / z + N_{ed}$ (see EN 1992-1-1:2011)
- x Distance between the theoretical point of support and concrete joint

Note to figure A1.1 to A1.3 and figure A2.1 to A2.2

In the figures no traverse reinforcement is plotted, the transverse reinforcement as required by EN 1992-1-1:2011 shall be present.

The shear transfer between old and new concrete shall be designed according to EN 1992-1-1:2011

Preparation of joints according to **Annex B 3** of this document.

Figures not to scale

Rebar connection with injection system Selkent SEL-EPA Plus

Product description

Installation conditions and application examples reinforcing bars, part 2

Annex A2

Installation conditions and application examples Selkent rebar anchor FRA

Figure A3.1:

Lap to a foundation of a column under bending.

1. Shear lug (or fastener loaded in shear)
2. Selkent rebar anchor FRA (tension only)
3. Existing stirrup / reinforcement for overlap (lap splice)
4. Slotted hole

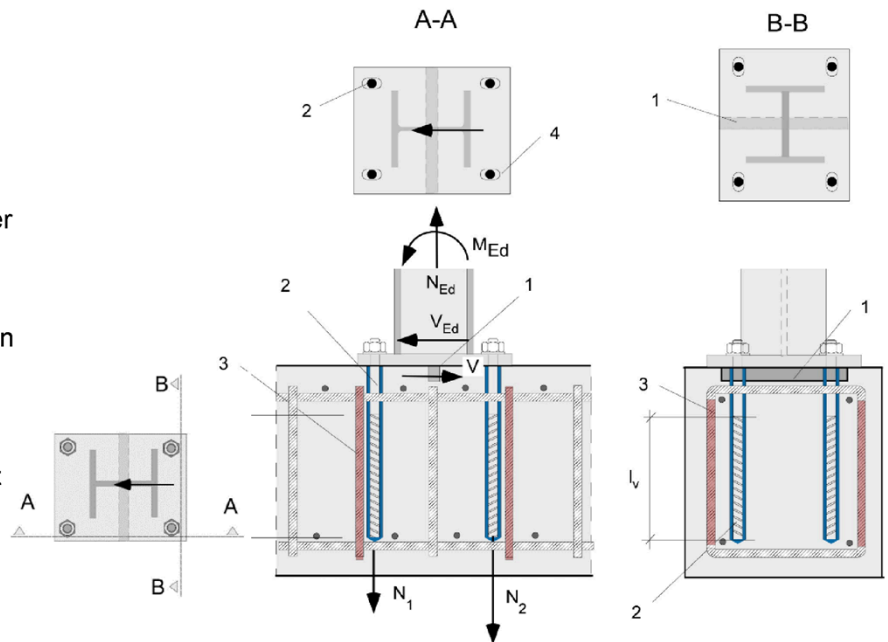
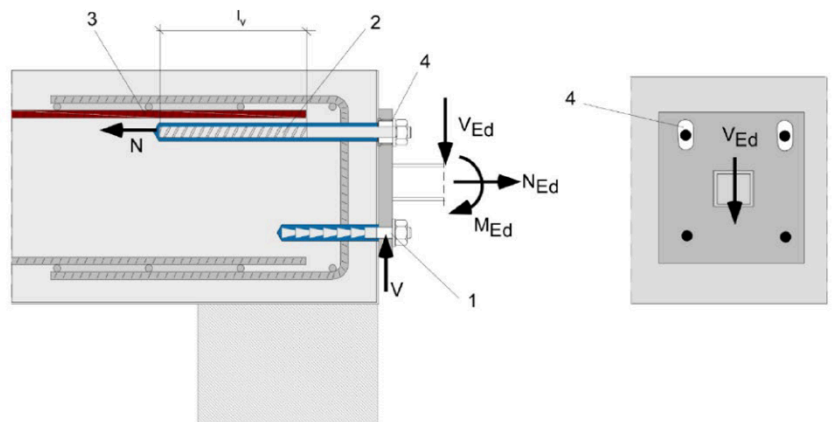

Figure A3.2:

Lap of the anchoring of guardrail posts or anchoring of cantilevered building components.

In the anchor plate, the drill holes for the Selkent rebar anchors FRA have to be designed as slotted holes with axial direction to the shear force.

1. Fastener for shear load transfer
2. Selkent rebar anchor FRA (tension only)
3. Existing stirrup / reinforcement for overlap (lap splice)
4. Slotted hole



The required transverse reinforcement acc. to EN 1992-1-1:2011 is not shown in the figures. **The Selkent rebar anchor FRA may be only used for axial tensile force.** The tensile force must be transferred by lap to the existing reinforcement of the building. The transfer of the shear force has to be ensured by suitable measure, e.g. by means of shear force or anchors with European Technical Assessment (ETA).

Figures not to scale

Rebar connection with injection system Selkent SEL-EPA Plus

Product description

Installation conditions and application examples Selkent rebar anchors FRA

Annex A3

Overview system components

Injection cartridge (shuttle cartridge) SEL-EPA Plus with sealing cap; Sizes: 360 ml, 825 ml

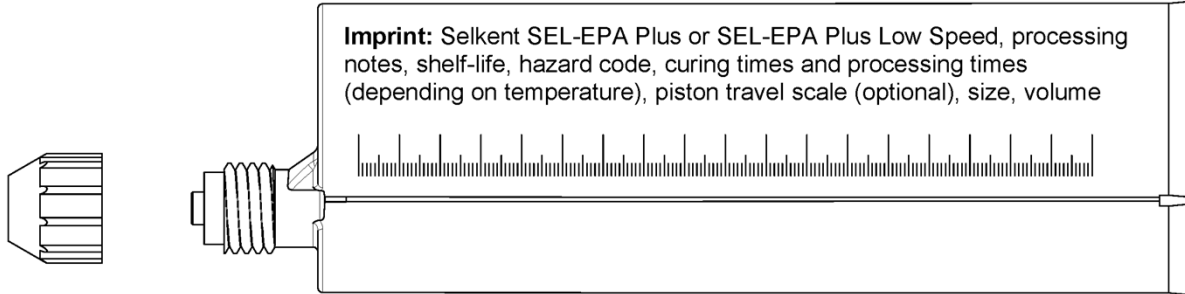

Injection cartridge (coaxial cartridge) SEL-EPA Plus with sealing cap; Sizes: 300 ml, 380 ml, 400 ml, 410 ml

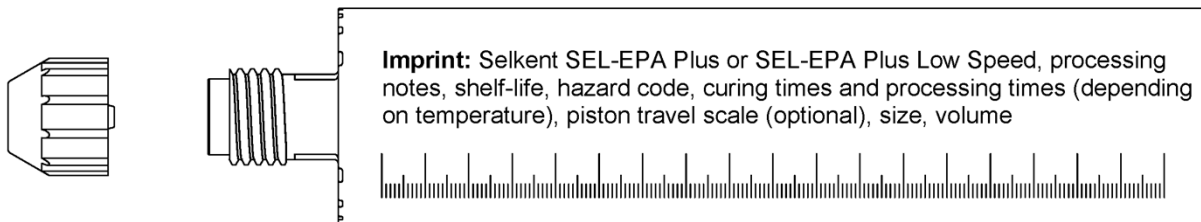

Static mixer for Selkent SEL-EPA Plus for injection cartridges up to 410 ml

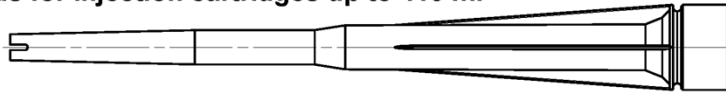

Static mixer for Selkent SEL-EPA Plus for injection cartridges 825 ml

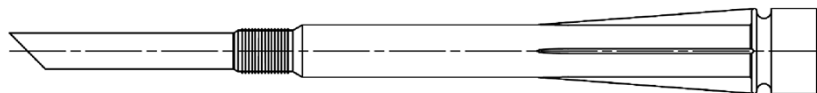

**Injection adapter and extension tube Ø 9 for static mixer for Selkent SEL-EPA Plus;
Injection adapter and extension tube Ø 9 or Ø 15 for static mixer for Selkent SEL-EPA Plus**

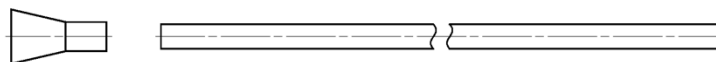

Reinforcing bar (rebar) Sizes: $\phi 8$, $\phi 10$, $\phi 12$, $\phi 14$, $\phi 16$, $\phi 18$, $\phi 20$, $\phi 22$, $\phi 24$, $\phi 25$, $\phi 28$, $\phi 30$, $\phi 32$, $\phi 40$



Selkent rebar anchor FRA / FRA HCR Sizes: M12, M16, M20, M24

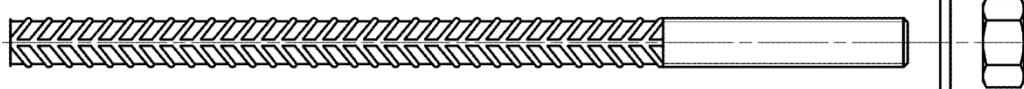

Selkent Blow out pump



Compressed-air cleaning tool with compressed-air nozzle

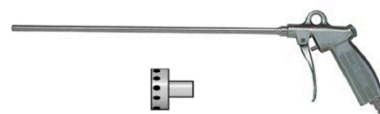

Figures not to scale

Rebar connection with injection system Selkent SEL-EPA Plus

Product description

Overview system components; Injection mortar, static mixer, injection adapter, reinforcing bar, Selkent rebar anchor FRA, cleaning tools

Annex A4

Properties of reinforcing bars (rebar)

Figure A5.1:



- The minimum value of related rib area $f_{R,min}$ according to EN 1992-1-1:2011
- The maximum outer rebar diameter over the ribs shall be:
 - The nominal diameter of the bar with rib $\phi + 2 \cdot h$ ($h \leq 0,07 \cdot \phi$)
 - (ϕ : Nominal diameter of the bar; h_{rib} = rib height of the bar)

Table A5.1: Installation conditions for rebars

Nominal diameter of the bar		ϕ	8 ¹⁾	10 ¹⁾	12 ¹⁾	14	16	18	20	22	24	25 ¹⁾	28	30	32	40				
Nominal drill hole diameter	d_0	[mm]	10	12	12	14	14	16	18	20	25	25	30	30	30	35	35	40	40	55
Drill hole depth	h_0		$h_0 = l_v$																	
Effective embedment depth	l_v		acc. to static calculation																	
Minimum thickness of concrete member	h_{min}		$l_v + 30$ (≥ 100)						$l_v + 2d_0$											

¹⁾ Both drill hole diameters can be used.

Table A5.2: Materials of rebars

Designation	Reinforcing bar (rebar)
Reinforcing bar EN 1992-1-1:2011, Annex C	Bars and de-coiled rods class B or C with f_{yk} and k according to NDP or NCI of EN 1992-1-1/NA $f_{uk} = f_{tk} = k \cdot f_{yk}$

Figures not to scale

Rebar connection with injection system Selkent SEL-EPA Plus

Product description
Properties and materials of reinforcing bars (rebar)

Annex A5

Properties of Selkent rebar anchors FRA

Figure A6.1:

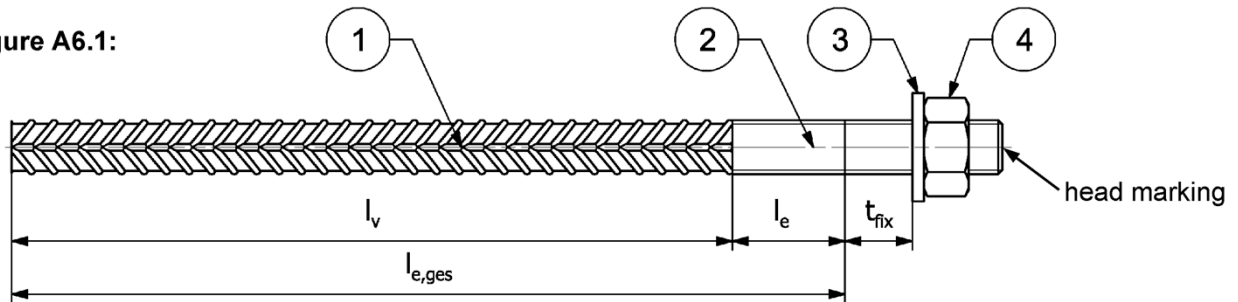

Head marking e.g.:  FRA (for stainless steel)

 FRA HCR (for high corrosion-resistant steel)

Table A6.1: Installation conditions for Selkent rebar anchors FRA

Thread diameter		M12 ²⁾		M16	M20	M24 ²⁾	
Nominal diameter	ϕ [mm]	12		16	20	25	
Nominal drill bit diameter	d_0 [mm]	14	16	20	25	30	35
Drill hole depth ($h_0 = l_{e,ges}$)	$l_{e,ges}$ [mm]	$l_v + l_e$					
Effective embedment depth	l_v [mm]	according to static calculation					
Distance concrete surface to welded joint	l_e [mm]	100					
Maximum Diameter of clearance hole in the fixture ¹⁾	Pre-positioned d_f [mm]	14		18	22	26	
	Push through d_f [mm]	16	18	22	26	32	40
Minimum thickness of concrete member	h_{min} [mm]	$h_0 + 30$		$h_0 + 2d_0$			
Maximum torque moment for attachment of the fixture	$\max T_{inst}$ [Nm]	50		100	150	150	

¹⁾ For bigger clearance holes in the fixture see EN 1992-4:2018.

²⁾ Both drill bit diameters can be used.

Table A6.2: Materials of Selkent rebar anchors FRA





Part	Description	Materials	
		FRA Corrosion resistance class CRC III acc. to EN 1993-1-4:2006+A1:2015	FRA HCR Corrosion resistance class CRC V acc. to EN 1993-1-4: 2006+A1:2015
1	Reinforcing bar	Bars and de-coiled rods class B or C with f_{yk} and k according to NDP or NCI of EN 1992-1-1:NA; $f_{uk} = f_{tk} = k \cdot f_{yk}$; ($f_{yk} = 500 \text{ N/mm}^2$)	
2	Round bar with partial or full thread	Stainless steel, strength class 80, according to EN 10088-1:2023	High corrosion-resistant steel, strength class 80, according to EN 10088-1:2023
3	Washer ISO 7089:2000	Stainless steel, according to EN 10088-1: 2023	High corrosion-resistant steel, according to EN 10088-1: 2023
4	Hexagon nut	Stainless steel, strength class 80, acc. to EN ISO 3506-2:2020, according to EN 10088-1: 2023	High corrosion-resistant steel, strength class 80, acc. to EN ISO 3506-2:2020, according to EN 10088-1: 2023

Figures not to scale

Rebar connection with injection system Selkent SEL-EPA Plus

Product description
Properties and materials of Selkent rebar anchors FRA

Annex A6

Specifications of intended use part 1				
Table B1.1: Overview use and performance categories				
Anchorages subject to		SEL-EPA Plus with ...		
		Reinforcing bar 	Selkent rebar anchor FRA 	
Hammer drilling or compressed air drilling with standard drill bit 		all sizes		
Hammer drilling with hollow drill bit (fischer "FHD", Heller "Duster Expert", Bosch "Speed Clean", Hilti "TE-CD, TE-YD") 		Nominal drill bit diameter (d_0) 12 mm to 35 mm		
Use category	I1	dry or wet concrete	all sizes	
Characteristic resistance under static and quasi static loading, in	uncracked concrete	all sizes	Tables: C1.1 C1.2 C1.3 C2.1 C2.2 C2.3	all sizes
	cracked concrete			
Characteristic resistance under seismic loading		all sizes	Tables: C3.1 C3.2 C3.3 C4.1 C4.2 C4.3	No performance assessed
Installation direction	D3 (downward and horizontal and upwards (e.g. overhead))			
Installation temperature	$T_{i,min} = -10\text{ °C}$ to $T_{i,max} = +40\text{ °C}$			
Service temperature	Temperature range	-40 °C to +80 °C		(max. short term temperature +80 °C; max long term temperature +50 °C)
Resistance to fire	all sizes	Annex C6	all sizes	Table C5.3
Rebar connection with injection system Selkent SEL-EPA Plus				Annex B1
Intended use Specifications part 1				

Specifications of intended use part 2

Anchorage subject to:

- Static and quasi-static loading: reinforcing bar (rebar) size 8 mm to 40 mm; FRA M12 to M24.
- Characteristic resistance under seismic loading: reinforcing bar (rebar) size 8 mm to 40 mm.
- 50 and 100 years working life: reinforcing bar (rebar) size 8 mm to 40 mm.
- Resistance to fire: reinforcing bar (rebar) size 8 mm to 40 mm; FRA M12 to M24.

Base materials:

- Compacted reinforced or unreinforced normal weight concrete without fibres according to EN 206:2013+A2:2021.
- Concrete strength classes C12/15 to C50/60 according to EN 206:2013+ A2:2021 for static and quasi-static loading
- Concrete strength classes C16/20 to C50/60 according to EN 206:2013+ A2:2021 for seismic loading.
- Maximum chloride content of 0,40 % (CL 0.40) related to the cement content according to EN 206:2013+ A2:2021.
- Non-carbonated concrete

Note: In case of a carbonated surface of the existing concrete structure the carbonated layer shall be removed in the area of the post-installed rebar connection with a diameter of $\phi + 60$ mm prior to the installation of the new rebar. The depth of concrete to be removed shall correspond to at least the minimum concrete cover in accordance with EN1993-1-1:2011. The foregoing may be neglected if building components are new and not carbonated and if building components are in dry conditions.

Use conditions (Environmental conditions) for Selkent rebar anchors FRA

- For all conditions according to EN 1993-1-4:2006+A1:2015 corresponding to corrosion resistance classes to **Annex A6 Table A6.2**.

Design:

- The structural design according to EN 1992-1-1:2011; EN 1992-1-2:2011 and **Annex B3 and B4** are conducted under the responsibility of a designer experienced in the field of anchorages and concrete work.
- Verifiable calculation notes and drawings are prepared taking account of the forces to be transmitted.
- The actual position of the reinforcement in the existing structure shall be determined on the basis of the construction documentation and taken into account when designing.

Installation:

- The installation of post-installed rebar respectively Selkent rebar anchor FRA shall be done only by suitable trained installer and under Supervision on site; the conditions under which an installer may be considered as suitable trained and the conditions for Supervision on site are up to the Member States in which the installation is done.
- Check the position of the existing rebars (if the position of existing rebars is not known, it shall be determined using a rebar detector suitable for this purpose as well as on the basis of the construction documentation and then marked on the building component for the overlap joint).

Rebar connection with injection system Selkent SEL-EPA Plus

Intended use
Specifications part 2

Annex B2

General construction rules for post-installed rebars

Figure B3.1:

- Only tension forces in the axis of the rebar may be transmitted.
- The transfer of shear forces between new concrete and existing structure shall be designed additionally according to EN 1992-1-1:2011.
- The joints for concreting must be roughened to at least such an extent that aggregate protrude.

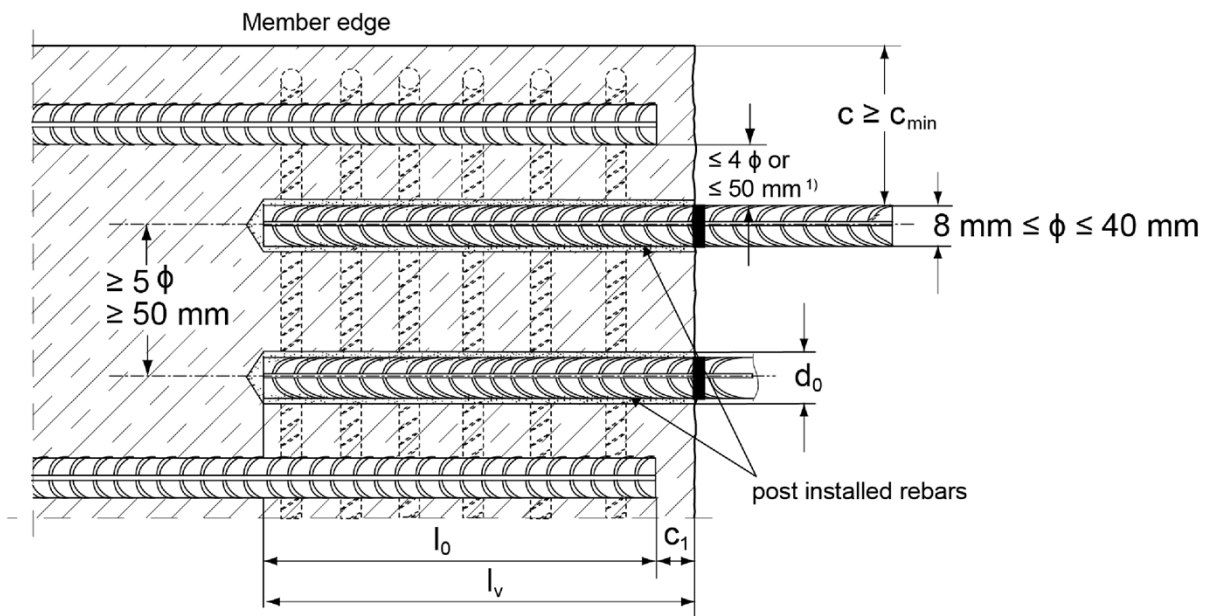

¹⁾ If the clear distance between lapped bars exceeds 4ϕ or 50 mm then the lap length shall be increased by the difference between the clear bar distance and the smaller 4ϕ or 50 mm.

- c concrete cover of post-installed rebar
 c_1 concrete cover at end-face of existing rebar
 c_{min} minimum concrete cover according to **Table B5.1** and to EN 1992-1-1:2011, Section 4.4.1.2
 ϕ nominal diameter of reinforcing bar
 l_0 lap length, according to EN 1992-1-1:2011
 l_v effective embedment depth, $\geq l_0 + c_1$
 d_0 nominal drill bit diameter, see **Annex B6**

Figures not to scale

Rebar connection with injection system Selkent SEL-EPA Plus

Intended use
General construction rules for post-installed rebars

Annex B3

General construction rules for post-installed Selkent rebar anchors FRA

Figure B4.1:

- Only tension forces in the axis of the Selkent rebar anchor FRA may be transmitted.
- The tension force must be transferred via an overlap joint to the reinforcement in the building part.
- The transmission of the shear load shall be ensured by appropriate additional measures, e.g. by shear lugs or by anchors with a European Technical Assessment (ETA).
- In the anchor plate, the holes for the tension anchor shall be executed as slotted holes with the axis in the direction of the shear force.

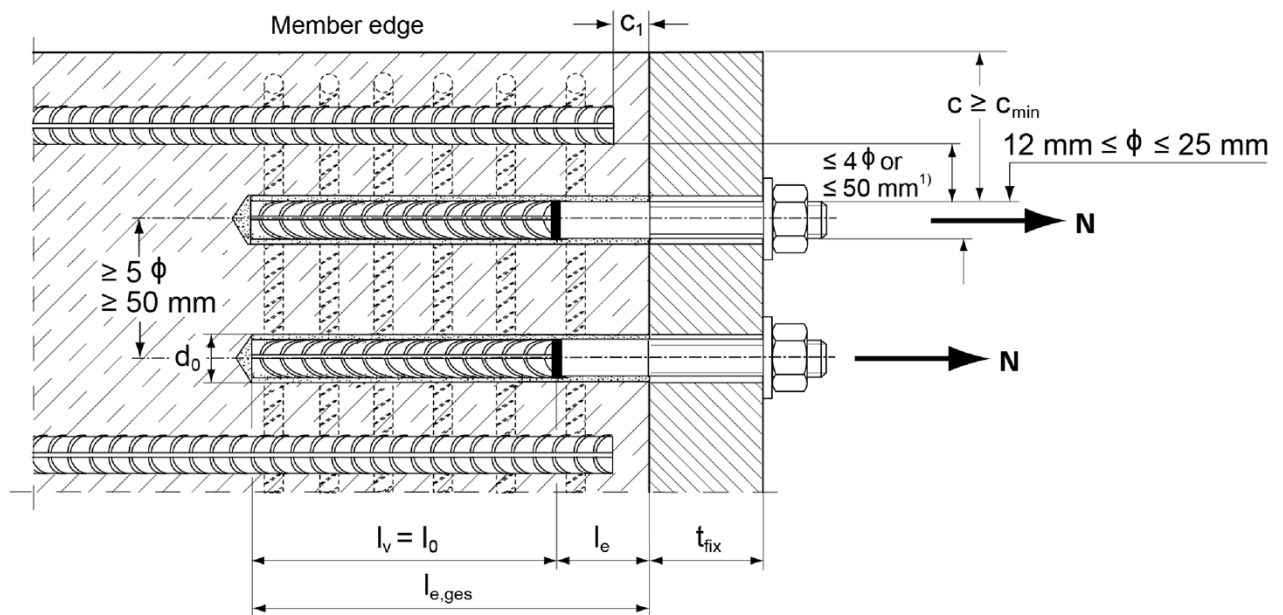

¹⁾ If the clear distance between lapped bars exceeds 4ϕ or 50 mm then the lap length shall be increased by the difference between the clear bar distance and the smaller 4ϕ or 50 mm.

c	concrete cover of post-installed Selkent rebar anchor FRA
c_1	concrete cover at end-face of existing rebar
c_{min}	minimum concrete cover according to Table B5.1 and to EN 1992-1-1:2011, Section 4.4.1.2
ϕ	nominal diameter of reinforcing bar
l_0	lap length, according to EN 1992-1-1:2011, Section 8.7.3
$l_{e,ges}$	overall embedment depth, $\geq l_0 + l_e$
d_0	nominal drill bit diameter, see Annex B6
l_e	length of the bonded in threaded part
t_{fix}	thickness of the fixture
l_v	effective embedment depth

Figures not to scale

Rebar connection with injection system Selkent SEL-EPA Plus

Intended use

General construction rules for post-installed Selkent rebar anchors FRA

Annex B4

Drilling method	nominal diameter of reinforcing bar ϕ [mm]	Minimum concrete cover c_{min}	
		Without drilling aid ²⁾ [mm]	With drilling aid ²⁾ [mm]
Hammer drilling with standard drill bit or hollow drill bit	< 25	30 mm + 0,06 $l_v \geq 2 \phi$	30 mm + 0,02 $l_v \geq 2 \phi$
	≥ 25	40 mm + 0,06 $l_v \geq 2 \phi$	40 mm + 0,02 $l_v \geq 2 \phi$
Compressed air drilling	< 25	50 mm + 0,08 l_v	50 mm + 0,02 l_v
	≥ 25	60 mm + 0,08 $l_v \geq 2 \phi$	60 mm + 0,02 $l_v \geq 2 \phi$

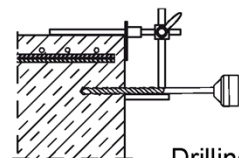

¹⁾ See Annex B3, figure B3.1 and Annex B4, figure B4.1

Note: The minimum concrete cover as specified in EN 1992-1-1:2011 must be observed. The same minimum concrete covers apply to rebar elements in case of seismic loading. $c_{min,seis} = 2 \phi$.

²⁾ For FRA (HCR) $l_{e,ges}$ instead of l_v .

Table B5.2: Dispensers and cartridge sizes corresponding to maximum embedment depth $l_{v,max}$

reinforcing bars (rebar)	Selkent rebar anchor FRA	Manual dispenser	Accu and pneumatic dispenser (small)	Accu and pneumatic dispenser (large)
		Cartridge size		
ϕ [mm]	thread [-]	< 500 ml		> 500 ml
		$l_{v,max} / l_{e,ges,max}$ [mm]		$l_{v,max} / l_{e,ges,max}$ [mm]
8	---	1000	1000	1800
10	---			
12	FRA M12 FRA HCR M12		1200	
14	---			
16	FRA M16 FRA HCR M16	700	1500	2000
18, 20, 22, 24	FRA M20 FRA HCR M20		1300	
25	FRA M24 FRA HCR M24		1000	
28	---	700	700	$T_i > 0 \text{ }^\circ\text{C}$: 1500 $T_i \leq 0 \text{ }^\circ\text{C}$: 2000
30, 32	---	700	700	
40	---	700	700	1300

Table B5.3: Conditions for use static mixer without an extension tube

Nominal drill hole diameter d_0	[mm]	10	12	14	16	18	20	24	25	30	35	40	55
		Drill hole depth h_0 by using SEL-EPA Plus up to 410ml		≤ 90	≤ 120	≤ 140	≤ 150	≤ 160	≤ 190	≤ 210			
SEL-EPA Plus for 825ml		-	-	≤ 90	≤ 160	≤ 180	≤ 190	≤ 220	≤ 250				

Rebar connection with injection system Selkent SEL-EPA Plus

Intended use
Minimum concrete cover;
dispenser and cartridge sizes corresponding to maximum embedment depth

Annex B5

Table B6.1: Working times t_{work} and curing times t_{cure}

Temperature in the anchorage base [°C]			Maximum working time ¹⁾ t_{work}		Minimum curing time ²⁾ t_{cure}	
			SEL-EPA Plus	SEL-EPA Plus Low Speed	SEL-EPA Plus	SEL-EPA Plus Low Speed
-10	to	-5	20 min ³⁾	-	12 h	-
>-5	to	0	20 min ³⁾	40 min	12 h	5 d
> 0	to	5	13 min ³⁾	30 min	3 h	48 h
> 5	to	10	9 min ³⁾	20 min	90 min	24 h
> 10	to	20	5 min	13 min	60 min	120 min
> 20	to	30	4 min	9 min	45 min	60 min
> 30	to	40	2 min ⁴⁾	7 min	35 min	45 min

¹⁾ Maximum time from the beginning of the injection to rebar / Selkent rebar anchor FRA setting and positioning.

²⁾ For wet concrete the curing time must be doubled.

³⁾ If the temperature in the concrete falls below 10 °C the cartridge must be warmed up to +15 °C.

⁴⁾ If the temperature in the concrete exceeds 30 °C the cartridge must be cooled down to +15 °C up to 20 °C.

Table B6.2: Installation tools for drilling and cleaning the bore hole and injection of the mortar

reinforcing bars (rebar) ϕ [mm]	Selkent rebar anchor FRA Designation	Drilling and cleaning				Injection	
		Nominal drill bit diameter d_0 [mm]	Diameter of cutting edge d_{cut} [mm]	Steel brush diameter d_b [mm]	Diameter of Selkent compressed-air nozzle [mm]	Diameter of extension tube [mm]	Injection adapter [colour]
8 ¹⁾	---	10	$\leq 10,50$	11	---	9	---
		12	$\leq 12,50$	12,5	11		nature
10 ¹⁾	---	12	$\leq 12,50$	12,5		15	9
		14	$\leq 14,50$	15	19		
12 ¹⁾	FRA M12	14	$\leq 14,50$	15		19	9 or 15
	FRA HCR M12	16	$\leq 16,50$	17	28		
14	---	18	$\leq 18,50$	19		32	9 or 15
16	FRA M16	20	$\leq 20,55$	21,5	37		
	FRA HCR M16	25	$\leq 25,55$	26,5		37	9 or 15
18	FRA M20	25	$\leq 25,55$	26,5	37		
	FRA HCR M20	30	$\leq 30,55$	32		38	15
22	---	30	$\leq 30,55$	32	38		
	---	35	$\leq 35,70$	37		38	15
25 ¹⁾	FRA M24	30	$\leq 30,55$	32	38		
	FRA HCR M24	35	$\leq 35,70$	37		38	15
28	---	35	$\leq 35,70$	37	38		
30	---	40	$\leq 40,70$	42		38	15
	---	40	$\leq 40,70$	42	38		
32	---	40	$\leq 40,70$	42		38	15
	---	55	$\leq 55,70$	58	38		
40	---	55	$\leq 55,70$	58		38	15

¹⁾ Both drill bit diameters can be used

Rebar connection with injection system Selkent SEL-EPA Plus

Intended use

Working times and curing times;
Installation tools for drilling and cleaning the bore hole and injection of the mortar

Annex B6

Safety regulations



Review the Safety Data Sheet (SDS) before use for proper and safe handling!
Wear well-fitting protective goggles and protective gloves when working with mortar SEL-EPA Plus / SEL-EPA Plus Low Speed.
Important: Observe the instructions for use provided with each cartridge.

Installation instruction part 1; Installation with SEL-EPA Plus / SEL-EPA Plus Low Speed

Hole drilling

Note: Before drilling, remove carbonized concrete; clean contact areas (see **Annex B 2**)
In case of aborted drill holes the drill hole shall be filled with mortar.

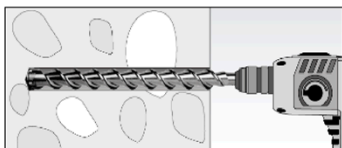
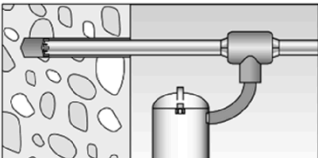
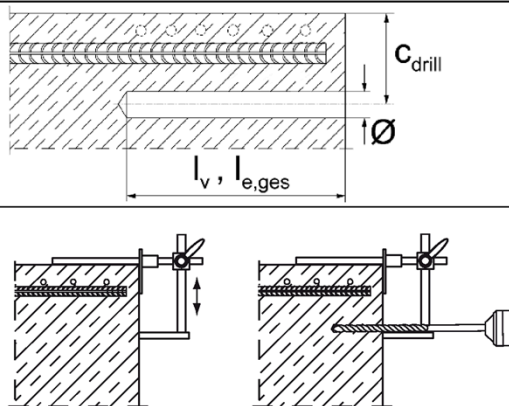
1a	<p>Hammer drilling or compressed air drilling</p> 	<p>Drill the hole to the required embedment depth using a hammer drill with carbide drill bit set in rotation hammer mode or a pneumatic drill. Drill bit sizes see Table B6.2.</p>
1b	<p>Hammer drilling with hollow drill bit</p> 	<p>Drill the hole to the required embedment depth using a hammer drill with hollow drill bit in rotation hammer mode. Dust extraction conditions see drill hole cleaning Annex B8. Drill bit sizes see Table B6.2.</p>
2		<p>Measure and control concrete cover c ($c_{\text{drill}} = c + \varnothing / 2$) Drill parallel to surface edge and to existing rebar. Where applicable use drilling aid.</p> <p>For holes $l_v > 20$ cm use drilling aid. Three different options can be considered: A) drilling aid B) Slat or spirit level C) Visual check</p> <p>Minimum concrete cover c_{min} see Table B5.1.</p>



Rebar connection with injection system Selkent SEL-EPA Plus

Intended use
Safety regulations; Installation instruction part 1, hole drilling

Annex B7

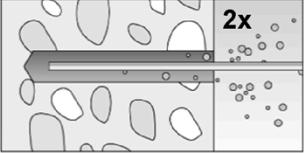
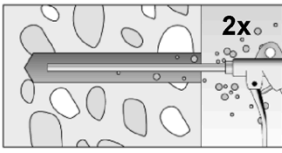
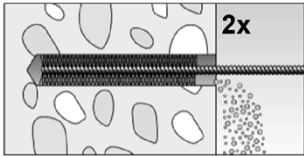
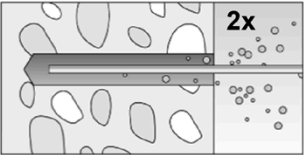
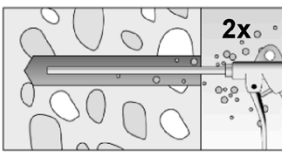

Installation instruction part 2; Installation with SEL-EPA Plus / SEL-EPA Plus Low Speed

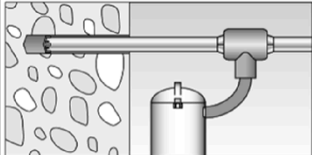
Drill hole cleaning

		Hammer or compressed air drilling		
3a		Clean the drill hole: For $d_0 < 18$ mm and depths l_v resp. $l_{e,ges} \leq 12 \cdot \phi$ blow out the hole two times by hand.		For $d_0 \geq 18$ mm and depths l_v resp. $l_{e,ges} > 12 \cdot \phi$ blow out the hole two times with oil-free compressed air ($p \geq 6$ bar). Use suitable compressed-air nozzle (see Table B6.2).
		Brush drill hole two times; for drill hole diameters $d_0 \geq 30$ mm attach brush to a power tool and brush hole with a speed of max. 550 revolutions per minute. For deep holes a brush extension is mandatory. Use suitable brushes (see Table B6.2).		
		Clean the drill hole: For $d_0 < 18$ mm and depths l_v resp. $l_{e,ges} \leq 12 \cdot \phi$ blow out the hole two times by hand.		For $d_0 \geq 18$ mm and depths l_v resp. $l_{e,ges} > 12 \cdot \phi$ blow out the hole two times with oil-free compressed air ($p \geq 6$ bar) Use suitable compressed-air nozzle (see Table B6.2).
		Hammer drilling with hollow drill bit		
3b		Use a suitable dust extraction system, e. g. fischer FVC 35 M or a comparable dust extraction system with equivalent performance data. Drill the hole with hollow drill bit. The dust extraction system has to extract the drill dust nonstop during the drilling process and must be adjusted to maximum power. No further drill hole cleaning necessary.		
Rebar connection with injection system Selkent SEL-EPA Plus				Annex B8
Intended use Installation instruction part 2, drill hole cleaning				

**Installation instruction part 3; Installation with
SEL-EPA Plus / SEL-EPA Plus Low Speed**

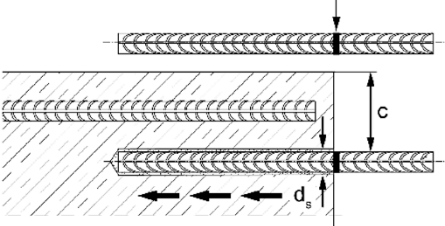
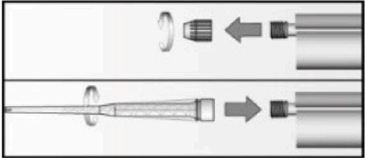
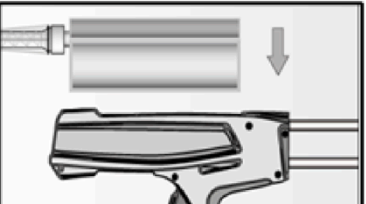
reinforcing bars (rebar) / Selkent rebar anchor FRA and cartridge preparation

4		<p>Before use, ensure that the rebar or the Selkent rebar anchor FRA is dry and free of oil or other residue. Mark the embedment depth l_v (e.g. with tape) Insert rebar in borehole, to verify drill hole depth and setting depth l_v resp. $l_{e,ges}$.</p>
5		<p>Twist off the sealing cap Twist on the static mixer (the spiral in the static mixer must be clearly visible).</p>
6		<p>Place the cartridge into a suitable dispenser.</p>
7		<p>Press out approximately 10 cm of mortar until the resin is permanently grey in colour. Mortar which is not grey in colour will not cure and must be disposed.</p>

Rebar connection with injection system Selkent SEL-EPA Plus

Intended use
Installation instruction part 3,
reinforcing bars (rebar) / Selkent rebar anchor FRA and cartridge preparation

Annex B9

Installation instruction part 4; Installation with SEL-EPA Plus / SEL-EPA Plus Low Speed

Injection of the mortar without extension tube

8a

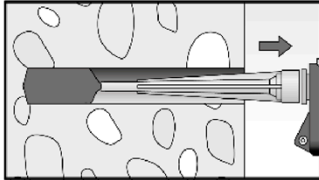

Inject the mortar from the back of the hole towards the front and slowly withdraw the static mixer step by step with each trigger pull. Avoid bubbles.

Fill holes approximately 2/3 full, to ensure that the annular gap between the rebar and the concrete will be completely filled with adhesive over the entire embedment length.

The conditions for mortar injection without extension tube can be found in **Table B5.3**.

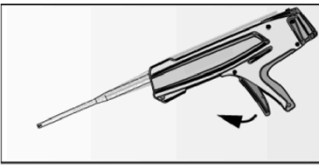

After injecting, release the dispenser. This will prevent further mortar discharge from the static mixer.

Injection of the mortar with extension tube

8b

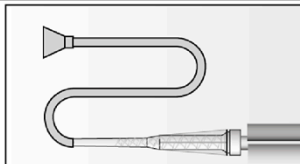

Assemble mixing nozzle SEL-V+, extension tube and appropriate injection adapter (see **Table B6.2**).

Mortar level mark

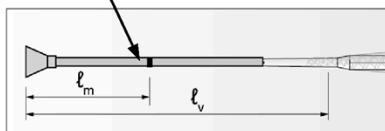

Mark the required mortar level l_m and embedment depth l_v resp. $l_{e,ges}$ with tape or marker on the injection extension tube.

a) Estimation:

$$l_m = \frac{1}{3} \cdot l_v \text{ resp. } l_m = \frac{1}{3} \cdot l_{e,ges} \text{ [mm]}$$

b) Precise equation for optimum mortar volume:

$$l_m = l_v \text{ resp. } l_{e,ges} \left(1,2 \cdot \frac{d_s^2}{d_0^2} - 0,2 \right) \text{ [mm]}$$

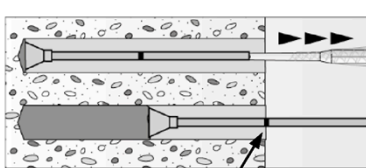

Mortar level mark

Insert injection adapter to back of the hole. Begin injection allowing the pressure of the injected adhesive mortar to push the injection adapter towards the front of the hole. Do not actively pull out!

Fill holes approximately 2/3 full, to ensure that the annular gap between the rebar and the concrete will be completely filled with adhesive over the embedment length.

When using an injection adapter continue injection until the mortar level mark l_m becomes visible.

Maximum embedment depth see **Table B5.2**.

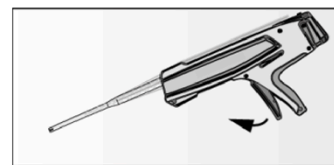

After injecting, release the dispenser. This will prevent further mortar discharge from static mixer.

Rebar connection with injection system Selkent SEL-EPA Plus

Intended use

Installation instruction part 4, mortar injection

Annex B10

Installation instruction part 5; Installation with SEL-EPA Plus / SEL-EPA Plus Low Speed

Insert rebar / Selkent rebar anchor FRA

9		<p>Insert the rebar / Selkent rebar anchor FRA slowly twisted into the borehole until the embedment mark is reached. Recommendation: Rotation back and forth of the reinforcement bar or the Selkent rebar anchor FRA makes pushing easy.</p>
10		<p>For overhead installation, support the rebar / Selkent rebar anchor FRA and secure it from falling till mortar started to harden, e.g. using wedges.</p>
11		<p>After installing the rebar or Selkent rebar anchor FRA the annular gap must be completely filled with mortar.</p> <p>Proper installation</p> <ul style="list-style-type: none"> • Desired embedment depth is reached l_v, resp. $l_{e,ges}$: embedment mark at concrete surface • Excess mortar flows out of the borehole after the rebar has been fully inserted up to the embedment mark.
12		<p>Observe the working time "t_{work}" (see Table B6.1), which varies according to temperature of base material. Minor adjustments to the rebar / Selkent rebar anchor FRA position may be performed during the working time "t_{work}".</p> <p>Full load may be applied only after the curing time "t_{cure}" has elapsed (see Table B 6.1).</p>
13		<p>Mounting the fixture for Selkent rebar anchor FRA, $\max T_{inst}$ see Table A6.1.</p>

Rebar connection with injection system Selkent SEL-EPA Plus

Intended use
Installation instruction part 5, insert rebar / Selkent rebar anchor FRA

Annex B11

Minimum anchorage length and minimum lap length for 50 years working life

The minimum anchorage length $l_{b,min}$ and the minimum lap length $l_{0,min}$ according to EN 1992-1-1:2011 shall be multiplied by the relevant amplification factor α_{lb} according to **Table C1.1**.

Table C1.1: Amplification factor α_{lb} related to concrete strength class and drilling method

Hammer drilling, hollow drilling and compressed air drilling

Rebar / Selkent rebar anchor FRA	Amplification factor α_{lb}									
	Concrete strength class									
	ϕ [mm]	C12/15	C16/20	C20/25	C25/30	C30/37	C35/45	C40/50	C45/55	C50/60
8 - 25	1,00						1,10		1,20	
28 - 32	1,00									
40	1,00			1,07	1,22	1,23	1,24	1,26	1,27	

Table C1.2: Bond efficiency factor k_b related to concrete strength class and drilling method

Hammer drilling, hollow drilling and compressed air drilling

Rebar / Selkent rebar anchor FRA	Bond efficiency factor k_b								
	Concrete strength class								
	ϕ [mm]	C12/15	C16/20	C20/25	C25/30	C30/37	C35/45	C40/50	C45/55
8 - 25	1,00								
28 - 32	1,00						0,91	0,84	0,84
40	1,00					0,90	0,82	0,76	0,71

Table C1.3: Design values of the bond strength $f_{bd,PIR}$ in N/mm² related to concrete strength class and drilling method for good bond conditions

$$f_{bd,PIR} = k_b \cdot f_{bd}$$

f_{bd} : Design value of the bond strength in N/mm² considering the concrete strength classes and the rebar diameter for good bond condition (for all other bond conditions multiply the values by $\eta_1 = 0,7$) and recommended partial factor $\gamma_c = 1,5$ according to EN 1992-1-1:2011

k_b : Bond efficiency factor according to **Table C1.2**

Hammer drilling, hollow drilling and compressed air drilling

Rebar / Selkent rebar anchor FRA	Bond strength $f_{bd,PIR}$ [N/mm ²]								
	Concrete strength class								
	ϕ [mm]	C12/15	C16/20	C20/25	C25/30	C30/37	C35/45	C40/50	C45/55
8 - 25	1,6	2,0	2,3	2,7	3,0	3,4	3,7	4,0	4,3
28 - 32	1,6	2,0	2,3	2,7	3,0	3,4	3,4	3,4	3,7
40	1,5	1,8	2,1	2,5	2,8				

Rebar connection with injection system Selkent SEL-EPA Plus

Performance

Amplification factor α_{lb} , bond efficiency factor k_b , design values of the bond strength $f_{bd,PIR}$

Annex C1

Minimum anchorage length and minimum lap length for 100 years working life

The minimum anchorage length $l_{b,min}$ and the minimum lap length $l_{0,min}$ according to EN 1992-1-1:2011 shall be multiplied by the relevant amplification factor $\alpha_{lb,100y}$ according to **Table C2.1**.

Table C2.1: Amplification factor $\alpha_{lb,100y}$ related to concrete strength class and drilling method

Hammer drilling, hollow drilling and compressed air drilling

Rebar / Selkent rebar anchor FRA	Amplification factor $\alpha_{lb,100y}$									
	Concrete strength class									
	ϕ [mm]	C12/15	C16/20	C20/25	C25/30	C30/37	C35/45	C40/50	C45/55	C50/60
8 - 12	1,00				1,10	1,20	1,20	1,30		
14 - 25	1,00				1,10	1,20	1,20	1,20		
28 - 32	1,00								1,10	
40	1,00	1,02	1,19	1,20	1,21	1,22	1,23	1,25		

Table C2.2: Bond efficiency factor $k_{b,100y}$ related to concrete strength class and drilling method

Hammer drilling, hollow drilling and compressed air drilling

Rebar / Selkent rebar anchor FRA	Bond efficiency factor $k_{b,100y}$									
	Concrete strength class									
	ϕ [mm]	C12/15	C16/20	C20/25	C25/30	C30/37	C35/45	C40/50	C45/55	C50/60
8 - 12	1,00									
14 - 25	1,00							0,92	0,86	
28 - 32	1,00				0,90	0,90	0,82	0,76	0,76	
40	1,00				0,89	0,80	0,73	0,67	0,63	

Table C2.3: Design values of the bond strength $f_{bd,PIR,100y}$ in N/mm² related to concrete strength class and drilling method for good bond conditions

$$f_{bd,PIR,100y} = k_{b,100y} \cdot f_{bd}$$

f_{bd} : Design value of the bond strength in N/mm² considering the concrete strength classes and the rebar diameter for good bond condition (for all other bond conditions multiply the values by $\eta_1 = 0,7$) and recommended partial factor $\gamma_c = 1,5$ according to EN 1992-1-1:2011

$k_{b,100y}$: Bond efficiency factor according to **Table C2.2**

Hammer drilling, hollow drilling and compressed air drilling

Rebar / Selkent rebar anchor FRA	Bond strength $f_{bd,PIR,100y}$ [N/mm ²]									
	Concrete strength class									
	ϕ [mm]	C12/15	C16/20	C20/25	C25/30	C30/37	C35/45	C40/50	C45/55	C50/60
8 - 12	1,6	2,0	2,3	2,7	3,0	3,4	3,7	4,0	4,3	
14 - 25	1,6	2,0	2,3	2,7	3,0	3,4	3,7	3,7	3,7	
28 - 32	1,6	2,0	2,3	2,7	2,7	3,0	3,0	3,0	3,4	
40	1,5	1,8	2,1	2,5						

Rebar connection with injection system Selkent SEL-EPA Plus

Performance

Amplification factor $\alpha_{lb,seis}$, bond efficiency factor $k_{b,seis}$, Design values of the bond strength $f_{bd,PIR,seis}$

Annex C2

Minimum anchorage length and minimum lap length under seismic conditions for 50 years working life

The minimum anchorage length $l_{b,min}$ and the minimum lap length $l_{0,min}$ according to EN 1992-1-1:2011 shall be multiplied by the relevant amplification factor $\alpha_{lb,seis}$ according to Table C3.1.

Table C3.1: Amplification factor $\alpha_{lb,seis}$ related to concrete strength class and drilling method

Hammer drilling, hollow drilling and compressed air drilling

Rebar ϕ [mm]	Amplification factor $\alpha_{lb,seis}$							
	Concrete strength class							
	C16/20	C20/25	C25/30	C30/37	C35/45	C40/50	C45/55	C50/60
8 - 25	1,00					1,10		1,20
28 - 32	1,00							
40	- ¹⁾	1,00	1,07	1,22	1,23	1,24	1,26	1,27

¹⁾ No performance assessed

Table C3.2: Bond efficiency factor $k_{b,seis}$ for hammer drilling, hollow drilling and compressed air drilling with a service life of 50 years

Hammer drilling, hollow drilling and compressed air drilling

Rebar ϕ [mm]	Bond efficiency factor $k_{b,seis}$							
	Concrete strength class							
	C16/20	C20/25	C25/30	C30/37	C35/45	C40/50	C45/55	C50/60
8 - 25	1,00							
28 - 32	1,00					0,91	0,84	0,84
40	- ¹⁾	1,00	0,86	0,76	0,69	0,63	0,58	0,54

¹⁾ No performance assessed

Table C3.3: Design values of the bond strength $f_{bd,PIR,seis}$ in N/mm² for hammer drilling, hollow drilling and compressed air drilling **under seismic action** and for good bond conditions with a service life of 50 years

$$f_{bd,PIR,seis} = k_{b,seis} \cdot f_{bd}$$

Hammer drilling, hollow drilling and compressed air drilling

Rebar ϕ [mm]	bond strength $f_{bd,PIR,seis}$ [N/mm ²]							
	Concrete strength class							
	C16/20	C20/25	C25/30	C30/37	C35/45	C40/50	C45/55	C50/60
8 - 25	2,0	2,3	2,7	3,0	3,4	3,7	4,0	4,3
28 - 32	2,0	2,3	2,7	3,0	3,4	3,4	3,4	3,7
40	- ¹⁾	2,1						

¹⁾ No performance assessed

Rebar connection with injection system Selkent SEL-EPA Plus

Performance

Amplification factor $\alpha_{lb,seis}$, bond efficiency factor $k_{b,seis}$, Design values of the bond strength $f_{bd,PIR,seis}$

Annex C3

Minimum anchorage length and minimum lap length under seismic conditions for 100 years working life

The minimum anchorage length $l_{b,min}$ and the minimum lap length $l_{0,min}$ according to EN 1992-1-1:2011 shall be multiplied by the relevant amplification factor $\alpha_{lb,seis,100y}$ according to Table C4.1.

Table C4.1: Amplification factor $\alpha_{lb,seis,100y}$ related to concrete strength class and drilling method

Hammer drilling, hollow drilling and compressed air drilling

Rebar ϕ [mm]	Amplification factor $\alpha_{lb,seis,100y}$							
	Concrete strength class							
	C16/20	C20/25	C25/30	C30/37	C35/45	C40/50	C45/55	C50/60
8 - 12	1,00				1,10	1,20	1,20	1,30
14 - 25	1,00				1,10	1,20	1,20	1,20
28 - 32	1,00							1,10
40	- ¹⁾	1,02	1,19	1,20	1,21	1,22	1,23	1,25

¹⁾ No performance assessed

Table C4.2: Bond efficiency factor $k_{b,seis,100y}$ for hammer drilling, hollow drilling and compressed air drilling with a service life of 100 years

Hammer drilling, hollow drilling and compressed air drilling

Rebar ϕ [mm]	Bond efficiency factor $k_{b,seis,100y}$							
	Concrete strength class							
	C16/20	C20/25	C25/30	C30/37	C35/45	C40/50	C45/55	C50/60
8 - 12	1,00							
14 - 25	1,00						0,92	0,86
28 - 32	1,00			0,90	0,90	0,82	0,76	0,76
40	- ¹⁾	0,86	0,74	0,66	0,59	0,54	0,50	0,47

¹⁾ No performance assessed

Table C4.3: Design values of the bond strength $f_{bd,PIR,seis,100y}$ in N/mm² for hammer drilling, hollow drilling and compressed air drilling **under seismic action** and for good bond conditions with a service life of 100 years

$$f_{bd,PIR,seis,100y} = k_{b,seis,100y} \cdot f_{bd}$$

Hammer drilling, hollow drilling and compressed air drilling

Rebar ϕ [mm]	bond strength $f_{bd,PIR,seis,100y}$ [N/mm ²]							
	Concrete strength class							
	C16/20	C20/25	C25/30	C30/37	C35/45	C40/50	C45/55	C50/60
8 - 12	2,0	2,3	2,7	3,0	3,4	3,7	4,0	4,3
14 - 25	2,0	2,3	2,7	3,0	3,4	3,7	3,7	3,7
28 - 32	2,0	2,3	2,7	2,7	3,0	3,0	3,0	3,4
40	- ¹⁾	1,8						

¹⁾ No performance assessed

Rebar connection with injection system Selkent SEL-EPA Plus

Performance

Amplification factor $\alpha_{lb,seis,100y}$, bond efficiency factor $k_{b,seis,100y}$, Design values of the bond strength $f_{bd,PIR,seis,100y}$

Annex C4

Table C5.1: Characteristic tensile yield strength for rebar part of Selkent rebar anchors FRA							
Selkent rebar anchor FRA / FRA HCR			M12	M16	M20	M24	
Characteristic tensile yield strength for rebar part							
Rebar diameter	ϕ	[mm]	12	16	20	25	
Characteristic tensile yield strength for rebar	f_{yk}	[N/mm ²]	500	500	500	500	
Partial factor for rebar part	$\gamma_{Ms,N}^{1)}$	[-]	1,15				
¹⁾ In absence of national regulations							
Table C5.2: Characteristic resistance to steel failure under tension loading of Selkent rebar anchors FRA							
Selkent rebar anchor FRA / FRA HCR			M12	M16	M20	M24	
Characteristic resistance to steel failure under tension loading							
Characteristic resistance	$N_{Rk,s}$	[kN]	62,0	111,0	173,0	236,5	
Partial factor							
Partial factor	$\gamma_{Ms,N}^{1)}$	[-]	1,4				
¹⁾ In absence of national regulations							
Table C5.3: Characteristics resistance to steel failure for Selkent rebar anchors FRA under tension loading and fire exposure R30 to R120							
Selkent rebar anchor FRA / FRA HCR			M12	M16	M20	M24	
Characteristic resistance to steel failure under tension loading and fire exposure	R30	$N_{Rk,s,fi}$	[kN]	2,5	4,7	7,4	10,6
	R60			2,1	3,9	6,1	8,8
	R90			1,7	3,1	4,9	7,1
	R120			1,3	2,5	3,9	5,6
Rebar connection with injection system Selkent SEL-EPA Plus			Annex C5				
Performance Characteristic tensile yield strength for rebar part of FRA; Design value of the steel bearing capacity $N_{Rk,s,fi}$ under fire exposure for Selkent rebar anchor FRA							

Design value of the ultimate bond strength $f_{bd,fi}$ resp. $f_{bd,fi,100y}$ at increased temperature for concrete strength classes C12/15 to C50/60 (all drilling methods)

The design value of the bond strength $f_{bd,fi}$ resp. $f_{bd,fi,100y}$ at increased temperature has to be calculated by the following equation:

$$f_{bd,fi,(100y)} = k_{fi,(100y)}(\theta) \cdot f_{bd,PIR,(100y)} \cdot \frac{\gamma_c}{\gamma_{m,fi}}$$

$$\text{If: } \theta > 74 \text{ } ^\circ\text{C} \quad k_{fi,(100y)}(\theta) = \frac{24,308 \cdot e^{-0,012 \cdot \theta}}{f_{bd,PIR,(100y)} \cdot 4,3} \leq 1,0$$

$$\text{If: } \theta > \theta_{\max} (317 \text{ } ^\circ\text{C}) \quad k_{fi}(\theta) = 0$$

- $f_{bd,fi}$ = Design value of the ultimate bond strength at increased temperature in N/mm² for working life 50 years
- $f_{bd,fi,100y}$ = Design value of the ultimate bond strength at increased temperature in N/mm² for working life 100 years
- θ = Temperature in °C in the mortar layer
- $k_{fi}(\theta)$ = Reduction factor at increased temperature for working life 50 years
- $k_{fi,100y}(\theta)$ = Reduction factor at increased temperature for working life 100 years
- $f_{bd,PIR}$ = Design value of the bond strength in N/mm² in cold condition according to **Table C1.3** considering the concrete strength classes, the rebar diameter, the drilling method and the bond conditions according to EN 1992-1-1:2011
- $f_{bd,PIR,100y}$ = Design value of the bond strength in N/mm² in cold condition according to **Table C2.3** considering the concrete strength classes, the rebar diameter, the drilling method and the bond conditions according to EN 1992-1-1:2011
- γ_c = 1,5 recommended partial factor according to EN 1992-1-1:2011
- $\gamma_{m,fi}$ = 1,0 recommended partial factor

For evidence at increased temperature the anchorage length shall be calculated according to EN 1992-1-1:2011 Equation 8.3 using the temperature-dependent ultimate design value of bond strength $f_{bd,fi}$ resp. $f_{bd,fi,100y}$.

Figure C6.1: Example graph of reduction factor $k_{fi,(100y)}(\theta)$ for concrete class C20/25 for good bond conditions

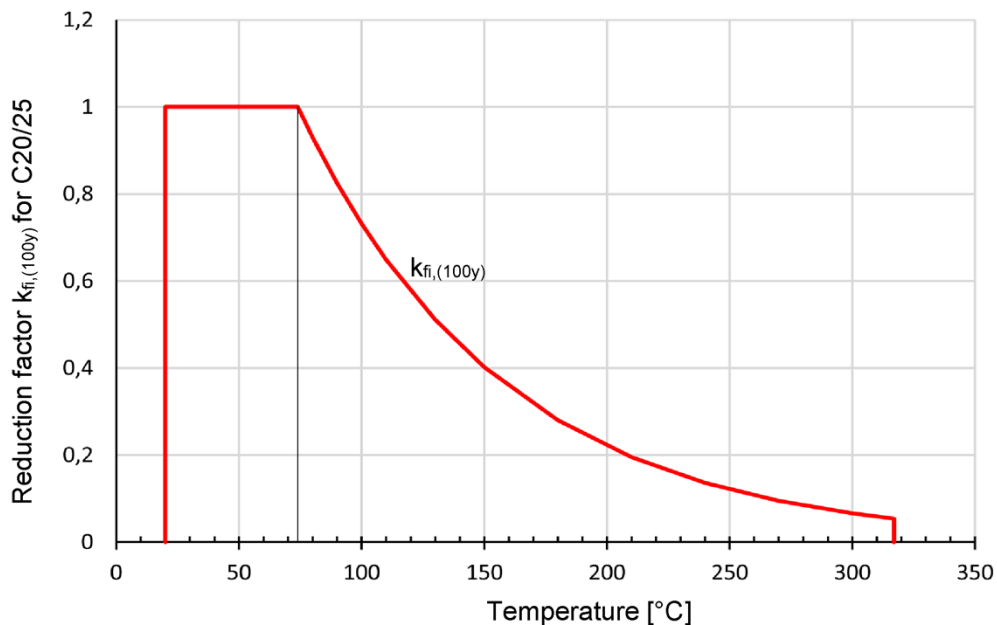

Rebar connection with injection system Selkent SEL-EPA Plus

Performance

Design value of bond strength $f_{bd,fi}$ resp. $f_{bd,fi,100y}$ at increased temperature

Annex C6