

Public-law institution jointly founded by the federal states and the Federation

European Technical Assessment Body
for construction products



European Technical Assessment

ETA-25/1110 of 26 January 2026

English translation prepared by DIBt - Original version in German language

General Part

Technical Assessment Body issuing the European Technical Assessment:

Deutsches Institut für Bautechnik

Trade name of the construction product

BigMat Injection system BigFix

Product family to which the construction product belongs

Bonded fasteners and bonded expansion fasteners for use in concrete

Manufacturer

BigMat Italia S.c.p.a.

Via Roma, 74 - Centro Direzionale
Colombiolo
20051 CASSINA DE' PECCHI (MI)
ITALY

Manufacturing plant

Werk BigMat

This European Technical Assessment contains

19 pages including 3 annexes which form an integral part of this assessment

This European Technical Assessment is issued in accordance with Article 95(4) of Regulation (EU) No 2024/3110, on the basis of

EAD 330499-02-0601

The European Technical Assessment is issued by the Technical Assessment Body in its official language. Translations of this European Technical Assessment in other languages shall fully correspond to the original issued document and shall be identified as such.

Communication of this European Technical Assessment, including transmission by electronic means, shall be in full. However, partial reproduction may only be made with the written consent of the issuing Technical Assessment Body. Any partial reproduction shall be identified as such.

This European Technical Assessment may be withdrawn by the issuing Technical Assessment Body, in particular pursuant to information by the Commission in accordance with Article 36(3) of Regulation (EU) No 2024/3110.

Specific Part

1 Technical description of the product

The "BigMat Injection system BigFix" is a bonded anchor consisting of a cartridge with injection mortar according to Annex A2 and a steel element according to Annex A3.

The steel element is placed into a drilled hole filled with injection mortar and is anchored via the bond between metal part, injection mortar and concrete.

The product description is given in Annex A.

2 Specification of the intended use in accordance with the applicable European Assessment Document

The performances given in Section 3 are only valid if the anchor is used in compliance with the specifications and conditions given in Annex B.

The verifications and assessment methods on which this European Technical Assessment is based lead to the assumption of a working life of the anchor of at least 50 years. The indications given on the working life cannot be interpreted as a guarantee given by the producer, but are to be regarded only as a means for choosing the right products in relation to the expected economically reasonable working life of the works.

3 Performance of the product and references to the methods used for its assessment

3.1 Mechanical resistance and stability (BWR 1)

Essential characteristic	Performance
Characteristic resistance to tension load (static and quasi-static loading)	See Annex B3, C1 to C3
Characteristic resistance to shear load (static and quasi-static loading)	See Annex C2
Displacements under short-term and long-term loading	See Annex C4
Characteristic resistance and displacements for seismic performance categories C1 and C2	No performance assessed

3.2 Safety in case of fire (BWR 2)

Essential characteristic	Performance
Reaction to fire	Class A1
Resistance to fire	No performance assessed

3.3 Hygiene, health and the environment (BWR 3)

Essential characteristic	Performance
Content, emission and/or release of dangerous substances	No performance assessed

4 Assessment and verification of constancy of performance (AVCP) system applied, with reference to its legal base

In accordance with the European Assessment Document EAD 330499-02-0601 the applicable European legal act is: [96/582/EC].

The system to be applied is: 1

5 Technical details necessary for the implementation of the AVCP system, as provided for in the applicable European Assessment Document

Technical details necessary for the implementation of the AVCP system are laid down in the control plan deposited at Deutsches Institut für Bautechnik.

Issued in Berlin 26 January 2026 by Deutsches Institut für Bautechnik

Dipl.-Ing. Beatrix Wittstock
Head of Section

beglaubigt:
Baderschneider

Installation conditions part 1

Anchor rod FIS A / RG M (Anchor rod) and standard threaded rod (Threaded rod)

Pre-positioned installation

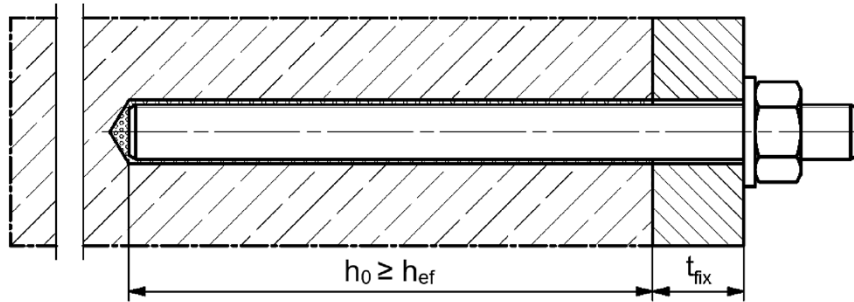

Push through installation (annular gap filled with mortar)

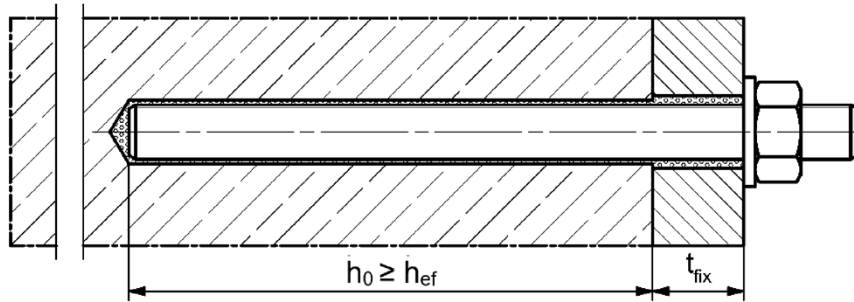

Pre-positioned or push through installation with subsequently injected fischer filling disc (annular gap filled with mortar)

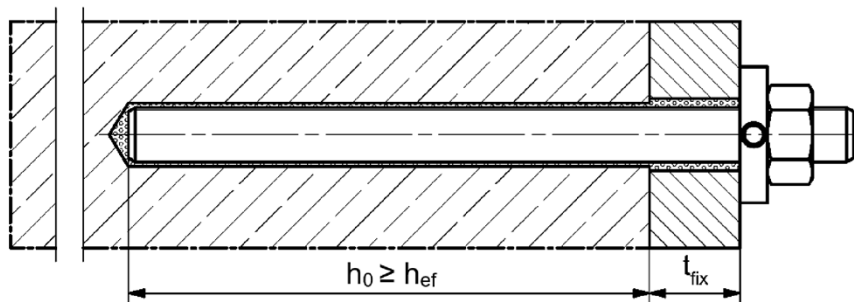

Figures not to scale

h_0 = drill hole depth

h_{ef} = effective embedment depth

t_{fix} = thickness of fixture

BigMat injection system BigFix

Product description
Installation conditions part 1

Annex A1

Overview system components part 1

Injection cartridge (shuttle cartridge) with sealing cap; Sizes: 360 ml, 825 ml

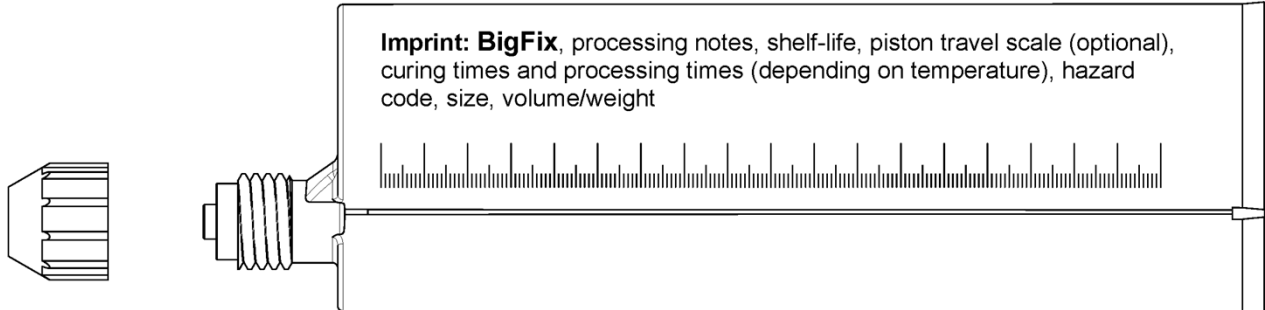

Injection cartridge (coaxial cartridge) with sealing cap; Sizes: 100 ml, 150 ml, 300 ml, 380 ml, 400 ml, 410 ml

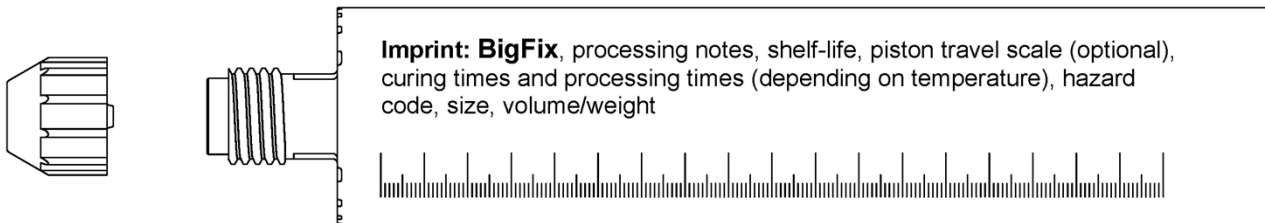

Static mixer FIS MR Plus for injection cartridges up to 410 ml

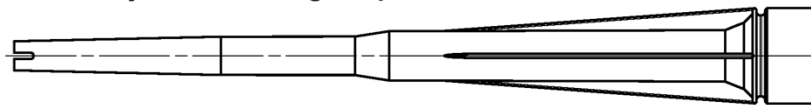

Static mixer FIS JMR for injection cartridges with 825 ml

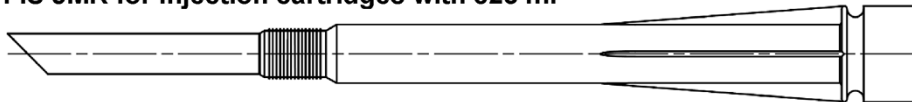

Injection adapter and extension tube Ø 9 for static mixer FIS MR Plus; Injection adapter and extension tube Ø 9 or Ø 15 for static mixer FIS JMR

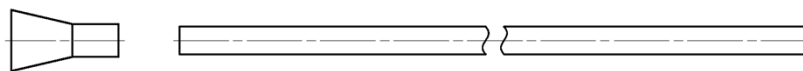

Cleaning brush BS



Blow-out pump AB G



Compressed-air cleaning tool APB



Figures not to scale

BigMat injection system BigFix

Product description

Overview system components part 1;
cartridges / static mixer / accessories

Annex A2

Overview system components part 2

Anchor rod / Threaded rod

Size: M8, M10, M12, M16, M20, M24

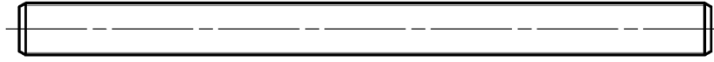

Washer / hexagon nut

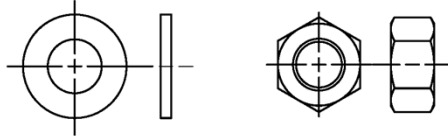

Filling disc FFD with injection adapter

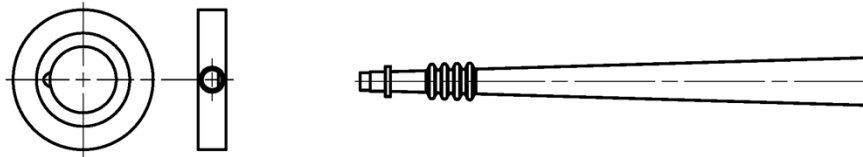

Figures not to scale



BigMat injection system BigFix

Product description

Overview system components part 2;
metal parts, injection adapter

Annex A3

Table A4.1: Materials				
Part	Designation	Material		
1	Injection cartridge	Mortar, hardener, filler		
	Steel grade	Steel zinc plated (zp, hdg)	Stainless steel R acc. to EN 10088-1:2023 Corrosion resistance class CRC III acc. to EN 1993-1-4: 2006+A2:2020	High corrosion resistant steel HCR acc. to EN 10088-1:2023 Corrosion resistance class CRC V acc. to EN 1993-1-4: 2006+ A2:2020
2	Anchor rod / Threaded rod	Property class 4.8, 5.8 or 8.8; EN ISO 898-1:2013 electroplated $\geq 5 \mu\text{m}$, EN ISO 4042:2022 or hot dip galvanised $\geq 40 \mu\text{m}$ EN ISO 10684:2004+AC:2009 $f_{uk} \leq 1000 \text{ N/mm}^2$ $A_5 > 8\%$ fracture elongation	Property class 50, 70 or 80 EN ISO 3506-1:2020 1.4401; 1.4404; 1.4578; 1.4571; 1.4439; 1.4362; 1.4062, 1.4662, 1.4462; EN 10088-1:2023 $f_{uk} \leq 1000 \text{ N/mm}^2$ $A_5 > 8\%$ fracture elongation	Property class 50, 70 or 80 EN ISO 3506-1:2020 or property class HRC 70 with $f_{yk} = 560 \text{ N/mm}^2$; 1.4565; 1.4529; EN 10088-1:2023 $f_{uk} \leq 1000 \text{ N/mm}^2$ $A_5 > 8\%$ fracture elongation
3	Washer ISO 7089:2000	electroplated $\geq 5 \mu\text{m}$, EN ISO 4042:2022 or hot dip galvanised $\geq 40 \mu\text{m}$ EN ISO 10684:2004+AC:2009	1.4401; 1.4404; 1.4578; 1.4571; 1.4439; 1.4362; EN 10088-1:2023	1.4565; 1.4529; EN 10088-1:2023
4	Hexagon nut	Property class 4, 5 or 8 acc. EN ISO 898-2:2022 electroplated $\geq 5 \mu\text{m}$, EN ISO 4042:2022 or hot dip galvanised $\geq 40 \mu\text{m}$ EN ISO 10684:2004+AC:2009	Property class 50, 70 or 80 acc. EN ISO 3506-2:2020 1.4401; 1.4404; 1.4578; 1.4571; 1.4439; 1.4362; EN 10088-1:2023	Property class 50, 70 or 80 acc. EN ISO 3506-2:2020 1.4565; 1.4529 EN 10088-1:2023
5	Filling disc FFD	electroplated $\geq 5 \mu\text{m}$, EN ISO 4042:2022 or hot dip galvanised $\geq 40 \mu\text{m}$ EN ISO 10684:2004+AC:2009	1.4401; 1.4404; 1.4578; 1.4571; 1.4439; 1.4362; EN 10088-1:2023	1.4565; 1.4529; EN 10088-1:2023
BigMat injection system BigFix				Annex A4
Product description Materials				

Specifications of intended use part 1			
Table B1.1: Overview use and performance categories			
Anchorages subject to		BigFix with ...	
		Anchor rod / Threaded rod 	
Hammer drilling with standard drill bit		all sizes	
Hammer drilling with hollow drill bit		Nominal drill bit diameter (d_0) 12 mm to 32 mm	
Static and quasi static loading, in	uncracked concrete	all sizes	Tables: C1.1 C2.1 C3.1 C4.1
	cracked concrete	- ¹⁾	- ¹⁾
Seismic performance category	C1	- ¹⁾	
	C2		
Use category	I1 dry or wet concrete	all sizes	
	I2 water filled hole	M12 to M24	
Installation direction		D3 (downward and horizontal and upwards (e.g. overhead))	
Installation temperature		$T_{i,min} = 0\text{ °C}$ to $T_{i,max} = +40\text{ °C}$ for the standard variation of temperature after installation	
Service temperature	Temperature range I	-40 °C to +80 °C	(max. short term temperature +80 °C; max. long term temperature +50 °C)
	Temperature range II	-40 °C to +120 °C	(max. short term temperature +120 °C; max. long term temperature +72 °C)
¹⁾ Performance not assessed.			
BigMat injection system BigFix			Annex B1
Intended use Specifications part 1			

Specifications of intended use part 2

Base materials:

- Compacted reinforced or unreinforced normal weight concrete without fibres of strength classes C20/25 to C50/60 according to EN 206:2013+A2:2021.

Use conditions (Environmental conditions):

- Fastener intended for use in structures subject to dry internal conditions (all materials).
- For all other conditions according to EN1993-1-4:2006+A1:2015 corresponding to corrosion resistance classes to Annex A4 Table A4.1.

Design:

- Fastenings are designed under the responsibility of an engineer experienced in fastenings and concrete work.
- Verifiable calculation notes and drawings are to be prepared taking account of the loads to be anchored. The position of the fastener is indicated on the design drawings (e. g. position of the fastener relative to reinforcement or to supports, etc.).
- Fastenings are designed in accordance with:
EN 1992-4:2018.

Installation:

- Fastener installation is to be carried out by appropriately qualified personnel and under the supervision of the person responsible for technical matters of the site.
- Fastening depth should be marked and adhered to installation.
- Overhead installation is allowed (necessary equipment see installation instruction).

BigMat injection system BigFix

Intended use
Specifications part 2

Annex B2

Table B3.1: Installation parameters for Anchor rods / Threaded rods

Anchor rods / Threaded rods		Thread	M8	M10	M12	M16	M20	M24
Nominal drill hole diameter	d_0	[mm]	10	12	14	18	24	28
Drill hole depth	h_0		$h_0 \geq h_{ef}$					
Effective embedment depth	$h_{ef, min}$		60	60	70	80	90	96
	$h_{ef, max}$		160	200	240	320	400	480
Minimum spacing and minimum edge distance	$s_{min} = c_{min}$		40	45	55	65	85	105
Diameter of the clearance hole of the fixture	pre-positioned installation d_f		9	12	14	18	22	26
	push through installation d_f		12	14	16	20	26	30
Minimum thickness of concrete member	h_{min}		$h_{ef} + 30 (\geq 100)$			$h_{ef} + 2d_0$		
Maximum installation torque	$\max T_{inst}$		[Nm]	10	20	40	60	120

Anchor rod / Threaded rods

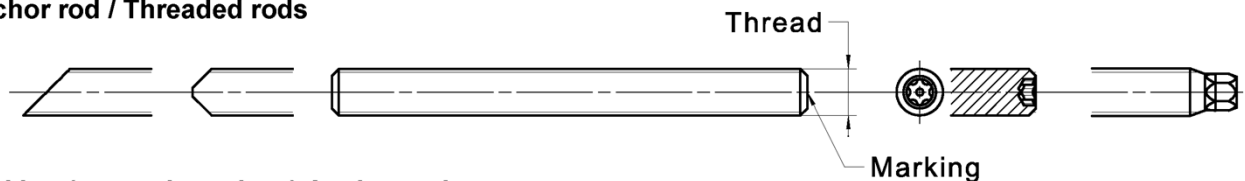

Marking (on random place) Anchor rod:

Steel zinc plated PC ¹⁾ 8.8	• or +	Steel hot-dip PC ¹⁾ 8.8	•
High corrosion resistant steel HCR PC ¹⁾ 50	•	High corrosion resistant steel HCR PC ¹⁾ 70	-
High corrosion resistant steel HCR PC ¹⁾ 80	(Stainless steel R property class 50 ¹⁾	~
Stainless steel R property class 80 ¹⁾	*		

Alternatively: Colour coding according to DIN 976-1: 2016

¹⁾ PC = property class

Installation conditions:

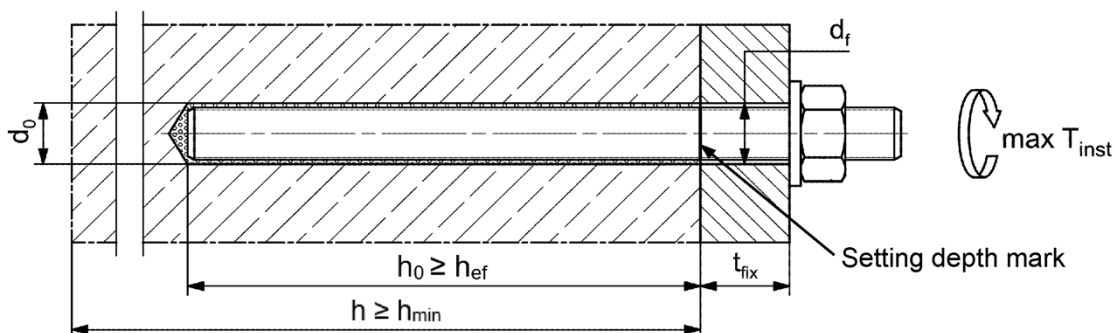

Commercial standard threaded rods, washers and hexagon nuts may also be used if the following requirements are fulfilled:

- Materials, dimensions and mechanical properties according to Annex A4, Table A4.1.
- Inspection certificate 3.1 according to EN 10204:2004, the documents have to be stored.
- Setting depth is marked.

Figures not to scale

BigMat injection system BigFix

Intended use

Installation parameters Anchor rods / Threaded rods

Annex B3

**Table B4.1: Parameters of the cleaning brush BS
(steel brush with steel bristles)**

The size of the cleaning brush refers to the drill hole diameter

Nominal drill hole diameter	d_0	[mm]	10	12	14	18	24	28
Steel brush diameter BS	d_b		11	14	16	20	26	30

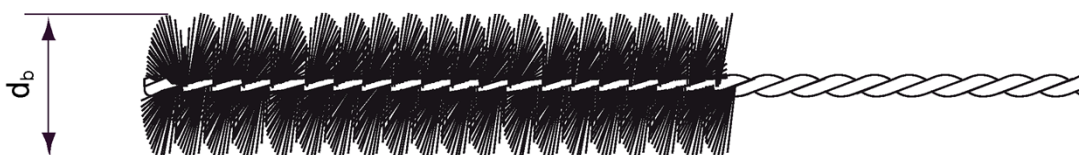

**Table B4.2 Maximum processing time of the mortar and minimum curing time
(During the curing time of the mortar the concrete temperature may not fall below the listed minimum temperature)**

Temperature at anchoring base [°C]	Maximum processing time t_{work}	Minimum curing time ¹⁾ t_{cure}
	BigFix	BigFix
> 0 to 5 ²⁾	13 min	3 h
> 5 to 10	9 min	90 min
> 10 to 20	5 min	60 min
> 20 to 30	4 min	45 min
> 30 to 40	2 min	35 min

¹⁾ In wet concrete or water filled holes the curing times must be doubled.

²⁾ Minimal cartridge temperature +5°C.

BigMat injection system BigFix

Intended use
Cleaning brush (steel brush)
Processing time and curing time

Annex B4

Installation instructions part 1

Drilling and cleaning the hole (hammer drilling with standard drill bit)

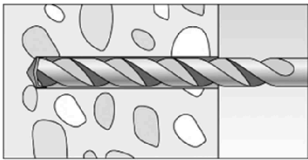
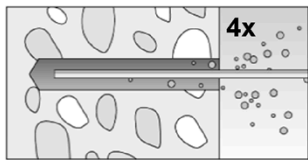
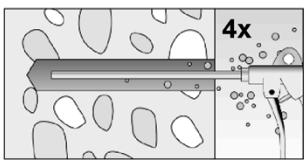
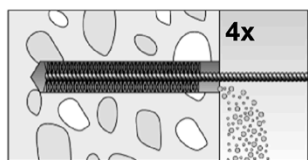
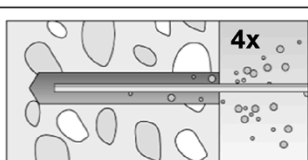
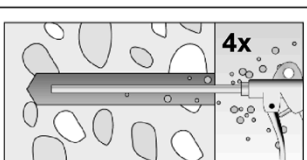
1		Drill the hole. Nominal drill hole diameter d_0 and drill hole depth h_0 see Tables B3.1 .		
2		Clean the drill hole: For $h_{ef} \leq 12d$ and $d_0 < 18$ mm blow out the hole four times by hand.		For $h_{ef} > 12d$ and / or $d_0 \geq 18$ mm blow out the hole four times with oil-free compressed air ($p \geq 6$ bar).
3		Brush the drill hole four times. For drill hole diameter ≥ 30 mm use a power drill. For deep holes use an extension. Corresponding brushes see Table B4.1		
4		Clean the drill hole: For $h_{ef} \leq 12d$ and $d_0 < 18$ mm blow out the hole four times by hand.		For $h_{ef} > 12d$ and / or $d_0 \geq 18$ mm blow out the hole four times with oil-free compressed air ($p \geq 6$ bar).

Go to step 5

Drilling and cleaning the hole (hammer drilling with hollow drill bit)

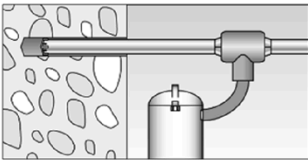
1		Check a suitable hollow drill (see Table B1.1) for correct operation of the dust extraction.
2		Use a suitable dust extraction system, e.g. fischer FVC 35 M or a comparable dust extraction system with equivalent performance data. Drill the hole with hollow drill bit. The dust extraction system has to extract the drill dust nonstop during the drilling process and must be adjusted to maximum power. Nominal drill hole diameter d_0 and drill hole depth h_0 see Tables B3.1 .

Go to step 5

BigMat injection system BigFix

Intended use
Installation instructions part 1

Annex B5

Installation instructions part 2

Preparing the cartridge

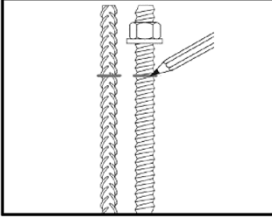
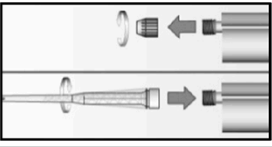
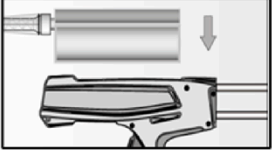
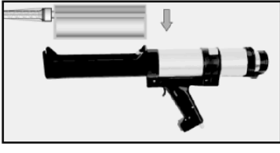
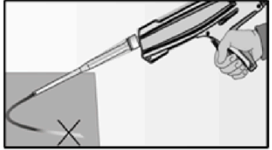
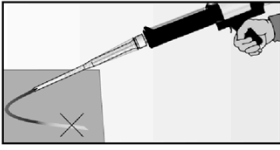
5		Mark the setting depth.
6		Remove the sealing cap. Screw on the static mixer (the spiral in the static mixer must be clearly visible).
7		 Place the cartridge into the dispenser.
8		 Extrude approximately 10 cm of material out until the resin is evenly grey in colour. Do not use mortar that is not uniformly grey.

Go to step 9

Injection of the mortar

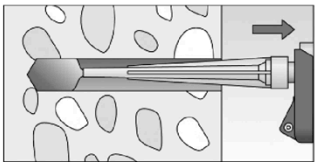
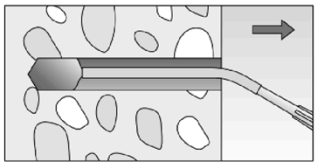
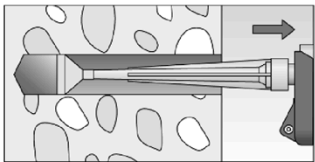
9	 <p>For $h_0 = h_{ef}$ fill approximately 2/3 of the drill hole with mortar. For $h_0 > h_{ef}$ more mortar is needed. Always begin from the bottom of the hole and avoid bubbles.</p>	 <p>For drill hole depth ≥ 150 mm use an extension tube.</p>	 <p>For overhead installation, deep holes ($h_0 > 250$ mm) use an injection adapter.</p>
---	--	--	---

Go to step 10



BigMat injection system BigFix

Intended use
Installation instructions part 2

Annex B6

Installation instructions part 3

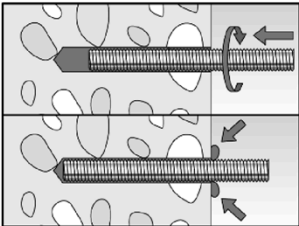
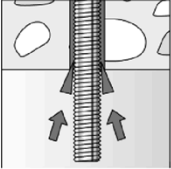
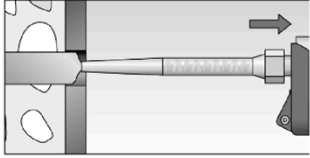
Installation of anchor rods

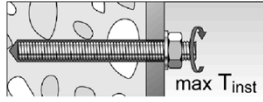
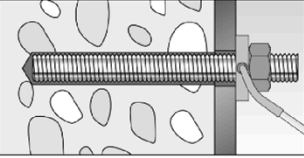
<p>10</p>		<p>Only use clean and oil-free metal parts. Push the anchor rod down to the bottom of the hole, turning it slightly while doing so. After inserting the metal parts, excess mortar must be emerged around the anchor element. If not, pull out the metal part immediately and reinject mortar.</p>
	 <p>For overhead installations support the metal part with wedges (e.g. centering wedges).</p>	 <p>For push through installation fill the annular gap with mortar</p>
<p>11</p>	 <p>Wait for the specified curing time t_{cure} see Table B4.2.</p>	<p>12</p>  <p>Mounting the fixture max T_{inst} see Tables B3.1.</p>
<p>Option</p>		<p>After the minimum curing time is reached, the gap between metal part and fixture (annular clearance) may be filled with mortar via the filling disc. Compressive strength $\geq 50 \text{ N/mm}^2$ (e.g. BigFix oder BigFix Pro). ATTENTION: By using filling disc reduces t_{fix} (usable length of the anchor).</p>

BigMat injection system BigFix

Intended use
Installation instructions part 3

Annex B7

Table C1.1: Characteristic resistance to steel failure under tension / shear loading of Anchor rods and Threaded rods

Anchor rod / Threaded rod		M8	M10	M12	M16	M20	M24		
Characteristic resistance to steel failure under tension loading ¹⁾									
Characteristic resistance $N_{Rk,s}$	Steel zinc plated	Property class 4.8	[kN]	14,6(13,2)	23,2(21,4)	33,7	62,8	98,0	141,2
		5.8		18,3(16,6)	29,0(26,8)	42,1	78,5	122,5	176,5
		8.8		29,2(26,5)	46,4(42,8)	67,4	125,6	196,0	282,4
	Stainless steel R and high corrosion resistant steel HCR	50		18,3	29,0	42,1	78,5	122,5	176,5
		70		25,6	40,6	59,0	109,9	171,5	247,1
		80		29,2	46,4	67,4	125,6	196,0	282,4
Partial factors ²⁾									
Partial factor $\gamma_{Ms,N}$	Steel zinc plated	Property class 4.8	[-]	1,50					
		5.8		1,50					
		8.8		1,50					
	Stainless steel R and high corrosion resistant steel HCR	50		2,86					
		70		1,87 / HCR: 1,50 ³⁾					
		80		1,60					
Characteristic resistance to steel failure under shear loading ¹⁾									
without lever arm									
Characteristic resistance $V_{Rk,s}^0$	Steel zinc plated	Property class 4.8	[kN]	8,7(7,9)	13,9(12,8)	20,2	37,6	58,8	84,7
		5.8		10,9(9,9)	17,4(16,0)	25,2	47,1	73,5	105,9
		8.8		14,6(13,2)	23,2(21,4)	33,7	62,8	98,0	141,2
	Stainless steel R and high corrosion resistant steel HCR	50		9,1	14,5	21,0	39,2	61,2	88,2
		70		12,8	20,3	29,5	54,9	85,7	123,5
		80		14,6	23,2	33,7	62,8	98,0	141,2
Ductility factor	k_7	[-]	1,0						
with lever arm									
Charact. resistance $M_{Rk,s}^0$	Steel zinc plated	Property class 4.8	[Nm]	14,9(12,9)	29,9(26,5)	52,3	132,9	259,6	448,8
		5.8		18,7(16,1)	37,3(33,2)	65,4	166,2	324,6	561,0
		8.8		29,9(25,9)	59,8(53,1)	104,6	265,9	519,3	897,6
	Stainless steel R and high corrosion resistant steel HCR	50		18,7	37,3	65,4	166,2	324,6	561,0
		70		26,2	52,3	91,5	232,6	454,4	785,4
		80		29,9	59,8	104,6	265,9	519,3	897,6
Partial factors ²⁾									
Charact. resistance $M_{Rk,s}^0$	Steel zinc plated	Property class 4.8	[-]	1,25					
		5.8		1,25					
		8.8		1,25					
	Stainless steel R and high corrosion resistant steel HCR	50		2,38					
		70		1,56 / HCR: 1,25 ³⁾					
		80		1,33					
¹⁾ Values in brackets are valid for undersized threaded rods with smaller stress area A_s for hot dip galvanised Threaded rods according to EN ISO 10684:2004+AC:2009. ²⁾ In absence of other national regulations. ³⁾ Only admissible for high corrosion resist. steel HCR, with $f_{yk} / f_{uk} \geq 0,8$ and $A_5 > 12\%$ (e.g. Anchor rods).									
BigMat injection system BigFix							Annex C1		
Performances Characteristic resistance to steel failure under tension / shear loading of Anchor rods and Threaded rods									

Table C2.1: Characteristic resistance to concrete failure under tension / shear loading									
Size		All sizes							
Characteristic resistance to concrete failure under tension loading									
Installation factor		γ_{inst}	[-]	See annex C3					
Factors for the compressive strength of concrete > C20/25									
Increasing factor ψ_c for cracked or uncracked concrete $\tau_{Rk(X,Y)} = \psi_c \cdot \tau_{Rk(C20/25)}$	C25/30	[-]		1,05					
	C30/37			1,10					
	C35/45			1,15					
	C40/50			1,19					
	C45/55			1,22					
	C50/60			1,26					
Splitting failure									
Edge distance	$h / h_{ef} \geq 2,0$	$C_{cr,sp}$	[mm]	1,0 h_{ef}					
	$2,0 > h / h_{ef} > 1,3$			4,6 $h_{ef} - 1,8 h$					
	$h / h_{ef} \leq 1,3$			2,26 h_{ef}					
Spacing	$S_{cr,sp}$			2 $C_{cr,sp}$					
Concrete failure									
Uncracked concrete	$k_{ucr,N}$	[-]		11,0					
Cracked concrete	$k_{cr,N}$			7,7					
Edge distance	$C_{cr,N}$	[mm]		1,5 h_{ef}					
Spacing	$S_{cr,N}$			2 $C_{cr,N}$					
Factors for sustained tension loading									
Temperature range				50 °C / 80 °C	72 °C / 120 °C				
Factor		ψ_{sus}^0	0,76	0,76	0,78				
Characteristic resistance to concrete failure under shear loading									
Installation factor		γ_{inst}	[-]	1,0					
Concrete pry-out failure									
Factor for pry-out failure		k_8	[-]	2,0					
Concrete edge failure									
Effective length of fastener in shear loading		l_f	[mm]	for $d_{nom} \leq 24$ mm: min (h_{ef} , 12 d_{nom}) for $d_{nom} > 24$ mm: min (h_{ef} , 8 d_{nom} ; 300 mm)					
Calculation diameters									
Size			M8	M10	M12	M16	M20	M24	
Anchor rods and Threaded rods		d_{nom}	[mm]	8	10	12	16	20	24
¹⁾ Anchor type not part of this assessment.									
BigMat injection system BigFix							Annex C2		
Performances Characteristic resistance to concrete failure under tension / shear loading									

Table C3.1: Characteristic resistance to combined pull-out and concrete failure for Anchor rods and Threaded rods in hammer drilled holes; uncracked or cracked concrete										
Anchor rod / Threaded rod		M8	M10	M12	M16	M20	M24			
Combined pull-out and concrete cone failure										
Calculation diameter	d	[mm]	8	10	12	16	20	24		
Uncracked concrete										
Characteristic bond resistance in uncracked concrete C20/25										
<u>Hammer-drilling with standard drill bit or hollow drill bit (dry or wet concrete)</u>										
Tem- perature range	I: 50 °C / 80 °C		$\tau_{Rk,ucr}$	[N/mm ²]	7,5	7,5	7,5	7,5	7,0	7,0
	II: 72 °C / 120 °C				6,5	6,5	6,5	6,5	6,0	6,0
<u>Hammer-drilling with standard drill bit or hollow drill bit (water filled hole dry or wet concrete)</u>										
Tem- perature range	I: 50 °C / 80 °C		$\tau_{Rk,cr}$	[N/mm ²]	- ¹⁾	- ¹⁾	7,5	7,5	7,0	7,0
	II: 72 °C / 120 °C				- ¹⁾	- ¹⁾	6,5	6,5	6,0	6,0
Installation factors										
Dry or wet concrete		γ_{inst}	[-]	1,0						
Water filled hole				- ¹⁾	1,2					
¹⁾ Performance not assessed.										
BigMat injection system BigFix								Annex C3		
Performances Characteristic resistance to combined pull-out and concrete failure for Anchor rod and Threaded rods										

Table C4.1: Displacements for Anchor rods / Threaded rods							
Anchor rods / Threaded rods		M8	M10	M12	M16	M20	M24
Displacement-Factors for tension loading¹⁾							
Uncracked concrete; Temperature range I, II							
δ_{N0} -Factor	[mm/(N/mm ²)]	0,09	0,09	0,10	0,10	0,10	0,10
$\delta_{N\infty}$ -Factor		0,10	0,10	0,12	0,12	0,12	0,13
Displacement-Factors for shear loading²⁾							
Uncracked or cracked concrete; Temperature range I, II							
δ_{V0} -Factor	[mm/kN]	0,11	0,11	0,10	0,10	0,09	0,09
$\delta_{V\infty}$ -Factor		0,12	0,12	0,11	0,11	0,10	0,10
¹⁾ Calculation of effective displacement: $\delta_{N0} = \delta_{N0\text{-Factor}} \cdot \tau$ $\delta_{N\infty} = \delta_{N\infty\text{-Factor}} \cdot \tau$ τ = acting bond strength under tension loading				²⁾ Calculation of effective displacement: $\delta_{V0} = \delta_{V0\text{-Factor}} \cdot V$ $\delta_{V\infty} = \delta_{V\infty\text{-Factor}} \cdot V$ V = acting shear loading			
BigMat injection system BigFix							Annex C4
Performances Displacements for Anchor rods / Threaded rods							