

Deutsches Institut für Bautechnik

Anstalt des öffentlichen Rechts

Kolonnenstr. 30 B
10829 Berlin
Germany

Tel.: +49(0)30 787 30 0
Fax: +49(0)30 787 30 320
E-mail: dibt@dibt.de
Internet: www.dibt.de



DIBt

Mitglied der EOTA
Member of EOTA

European Technical Approval ETA-10/0362

English translation prepared by DIBt - Original version in German language

Handelsbezeichnung <i>Trade name</i>	VARIO
Zulassungsinhaber <i>Holder of approval</i>	ECKELT GLAS GmbH Resthofstraße 18 4403 Steyr ÖSTERREICH
Zulassungsgegenstand und Verwendungszweck <i>Generic type and use of construction product</i>	VARIO Isolierglaselement mit tragender Verklebung und punktgestützter Befestigung <i>VARIO Insulated glass unit with structural sealant punctually anchored</i>
Geltungsdauer: <i>Validity:</i>	vom <i>from</i> 4 November 2010 bis <i>to</i> 4 November 2015
Herstellwerk <i>Manufacturing plant</i>	ECKELT GLAS GmbH Resthofstraße 18 4403 Steyr ÖSTERREICH

Diese Zulassung umfasst
This Approval contains

18 Seiten einschließlich 7 Anhänge
18 pages including 7 annexes



Europäische Organisation für Technische Zulassungen
European Organisation for Technical Approvals

I LEGAL BASES AND GENERAL CONDITIONS

- 1 This European technical approval is issued by Deutsches Institut für Bautechnik in accordance with:
 - Council Directive 89/106/EEC of 21 December 1988 on the approximation of laws, regulations and administrative provisions of Member States relating to construction products¹, modified by Council Directive 93/68/EEC² and Regulation (EC) N° 1882/2003 of the European Parliament and of the Council³;
 - Gesetz über das In-Verkehr-Bringen von und den freien Warenverkehr mit Bauprodukten zur Umsetzung der Richtlinie 89/106/EWG des Rates vom 21. Dezember 1988 zur Angleichung der Rechts- und Verwaltungsvorschriften der Mitgliedstaaten über Bauprodukte und anderer Rechtsakte der Europäischen Gemeinschaften (Bauproduktengesetz - BauPG) vom 28. April 1998⁴, as amended by law of 31 October 2006⁵;
 - Common Procedural Rules for Requesting, Preparing and the Granting of European technical approvals set out in the Annex to Commission Decision 94/23/EC⁶.
- 2 Deutsches Institut für Bautechnik is authorized to check whether the provisions of this European technical approval are met. Checking may take place in the manufacturing plant. Nevertheless, the responsibility for the conformity of the products to the European technical approval and for their fitness for the intended use remains with the holder of the European technical approval.
- 3 This European technical approval is not to be transferred to manufacturers or agents of manufacturers other than those indicated on page 1, or manufacturing plants other than those indicated on page 1 of this European technical approval.
- 4 This European technical approval may be withdrawn by Deutsches Institut für Bautechnik, in particular pursuant to information by the Commission according to Article 5(1) of Council Directive 89/106/EEC.
- 5 Reproduction of this European technical approval including transmission by electronic means shall be in full. However, partial reproduction can be made with the written consent of Deutsches Institut für Bautechnik. In this case partial reproduction has to be designated as such. Texts and drawings of advertising brochures shall not contradict or misuse the European technical approval.
- 6 The European technical approval is issued by the approval body in its official language. This version corresponds fully to the version circulated within EOTA. Translations into other languages have to be designated as such.

1 Official Journal of the European Communities L 40, 11 February 1989, p. 12

2 Official Journal of the European Communities L 220, 30 August 1993, p. 1

3 Official Journal of the European Union L 284, 31 October 2003, p. 25

4 *Bundesgesetzblatt Teil I 1998*, p. 812

5 *Bundesgesetzblatt Teil I 2006*, p. 2407, 2416

6 Official Journal of the European Communities L 17, 20 January 1994, p. 34

II SPECIFIC CONDITIONS OF THE EUROPEAN TECHNICAL APPROVAL

1 Definition of the product and intended use

1.1 Definition of the construction product

This European technical approval (ETA) covers a structural sealant glazing kit consisting of infill elements made of glass called "VARIO", which are fastened punctually to a supporting construction. For that purpose retaining devices, which are fixed to the supporting construction, grip into a U-profile which is glued into the insulating glass edge. The inner pane of the insulating glass unit is held mechanically and the outer pane is held via a load-bearing bonding. The U-profile is applied both either with or without an upstand. The upstand serves as emergency mounting bracket to secure the outer pane of the infill element in case of failure of the structural bond (Annex 1).

The dimensions of the infill elements made of glass amount to at least 400 mm x 800 mm (width x height and height x width respectively) and at most 2500 mm x 5000 mm (width x height and height x width respectively).

1.2 Intended use

The infill elements shall be factory-made and are installed in façades from a mullion and transom system. The angle of inclination to the vertical shall not exceed 10° with a slope to the inside. As overhead glazing a slope to the horizontal of 7° to 90° is possible, where in such a case laminated safety glass shall be used as lower pane. The structural bond shall not be permanently subject to tension.

The use of infill elements for the stiffening of other building elements or as safety barrier is not covered by this ETA.

According to the definition in ETAG 002-1⁷ type I or type II is possible for the present construction. For type I a mechanical self-weight support is necessary plus retaining devices to reduce danger in case of bond failure. For type II only a mechanical support is necessary but no retaining devices. Specific requirements of the Member States shall be observed when using the construction.

The provisions made in this European technical approval are based on an assumed working life of "VARIO" of 25 years, provided that the conditions laid down in sections 4.2/5.1/5.2 for packaging / transport / storage / installation / use / maintenance / repair are met. The indications given on the working life cannot be interpreted as a guarantee given by the producer, but are to be regarded only as a means for choosing the right products in relation to the expected economically reasonable working life of the construction.

⁷ ETAG-002-1: Guideline for European technical approval for Structural Sealant Glazing Systems (SSGS), Part 1: Supported and unsupported systems

2 Characteristics of product and methods of verification

2.1 Characteristics of the product

2.1.1 Insulating glass unit

A double glazing unit is installed for "VARIO". It consists of an exterior pane of heat-soaked thermally toughened soda lime silicate safety glass in accordance with Annex A and an interior pane of thermally toughened soda lime silicate safety glass in accordance with Annex A or laminated safety glass in accordance with Annex A. The thickness of the exterior pane is 8 mm or 10 mm. The exterior pane is treated mechanically according to the geometrical data given in Annex 2 and thus prepared for application of the emergency mounting bracket. The depth of the glass grinding may not exceed 6 mm. When a laminated safety glass is used for the interior pane, it shall be manufactured of double-pane float-glass (soda lime silicate glass), heat strengthened soda lime silicate glass or thermally toughened soda lime silicate safety glass in accordance with Annex A and a PVB-interlayer with a minimum thickness of 0.76 mm. The thickness of the individual panes of the laminated safety glass shall be at least 4 mm. If thermally toughened soda lime silicate safety glass is used as interior pane, the pane thickness can vary from 6 mm to 10 mm.

The glass panes entirely or partially enamelled may only be used, if their adhesive behaviour has been verified according to ETAG 002-1 with the adhesive "Dow Corning 3362 HD" in the ETA-03/003 or an other European technical approval. If other enamellings or coatings of the glass panes are foreseen the bonded area shall be left out from this enamelling or coating. Furthermore it shall be observed that when using the coated glass according to EN 1096-4⁸ the coated glass surface may not be oriented towards the PVB-interlayer.

The glass edges of the exterior pane shall either be grounded or polished. In the area of glass grinding damage to the edges is not permitted.

2.1.2 U-profile with or without an upstand (emergency retaining device, agraffe)

In the area of the load-bearing insulating glass edge a U-profile of the length of 100 mm is glued at a distance of 300 - 600 mm depending on the static requirement (Annexes 1 and 1a). The U-profile can have an upstand of 40 mm in width which bites into the lateral slot of the external insulating glass pane and thus serves for the external pane as mechanical protection in case of bond failure. Prior to pressing the agraffe silicone is injected in the grinding. The U-profile consists of stainless steel material No 1.4016 and strength class S235. More detailed material information is deposited with Deutsches Institut für Bautechnik.

2.1.3 Spacer and sealing

The spacers are applied for which a system check according to EN 1279-2⁹ is available. The edge seal of the insulating glass is manufactured with a primary seal BU-S (polyisobutylene) by Kömmerling Chemische Fabrik GmbH, Pirmasens, and a secondary seal (load-bearing insulating glass edge) of silicone adhesive DC 3362 HD by Dow Corning GmbH, Wiesbaden (2.1.4). For backfilling the joint between the glass panes the compatible closed-cell round profiles PE or silicone profiles shall be used. The compatibility verification with the load-bearing silicone sealant shall be confirmed in each case of use. As round profile Climafill standard PE can be used.

⁸ EN 1096-4: Glass in building - Coated glass - Part 4: Evaluation of conformity/Product standard

⁹ EN 1279-2: Glass in building - Insulating glass units - Part 2: Long term test method and requirements for moisture penetration

2.1.4 Structural sealant

For the load-bearing insulating glass edge seal the structural sealant DC 3362 HD shall be used according to ETA-03/0003¹⁰. The structural sealant "Dow Corning 3362 HD" is a two-component silicone sealant that can be used for installation of panes of insulating glass according to EN 1279-5¹¹ and ETAG 002-1. The width of the silicone bonding is at least 16 mm. The processing requirements of the structural sealant manufacturer shall be observed when the bonded joint is manufactured at the factory.

2.1.5 Glass support

Supporting devices with a width of 100 mm in accordance with Annexes 3 and 3a bear the self-weight of the glass. As contact material silicone or polypropylene setting blocks are used for which compatibility with the load-bearing silicone sealant is verified. For instance the standard block GLSV of polypropylene by Gluske BKV GmbH, Wuppertal can be used as contact material. The measurement of the supporting device depends on the total thickness of the insulating glass unit. It shall be ensured that the outer pane of the insulating glass unit is supported to at least two thirds of the pane thickness. It shall not be padded in the area of U-profile.

2.1.6 Screw-retaining devices

For fixing the infill elements retaining devices shall be used that are able to carry stresses according to section 2.2.4. Retaining devices with proven load-bearing capacities are given in the European technical approvals ETA-05/0114 and ETA-09/0335. Further proven retaining devices are possible. Their load-bearing capacity is not subject of this ETA. For all applicable retaining devices geometrical specifications shall be observed. The following minimum dimensions shall apply: 9 mm x 14 mm (anchoring depth and support width).

For the positioning of the retaining devices it shall be observed that they are situated 250 mm off the corner in the case of the horizontal pane edge and 150 mm in the case of the vertical pane edge (Annexes 3 and 3a).

2.1.7 Joint sealing

After assembly, the joints between infill elements are to be sealed using one of the sealants mentioned below:

- DC 791 (Dow Corning) or
- DC 797 (Dow Corning)

2.1.8 Requirement for the preparation of the adhesion surfaces

The processing requirements of the system's supplier by ECKELT GLAS GmbH and the data of the structural sealant manufacturer regarding the pre-treatment of contact surfaces and the structural sealant processing according to section 2.1.4, which were deposited with Deutsches Institut für Bautechnik, shall be considered.

2.2 Method of verification

2.2.1 General

The assessment of the fitness for the intended use of the infill elements in relation to the essential requirements for safety in case of fire (ER 2), for hygiene, health and the environment (ER 3), for safety in use (ER 4) and for energy economy and heat retention (ER 6) has been made in accordance with the "Guideline for European Technical Approval for Structural Sealant Glazing Kits" (ETAG 002-1).

¹⁰ ETA-03/0003 "DOW CORNING 3362 and 3362 HD; Sealant used in structural and non-structural edge seal of insulated glass unit for use in structural sealant glazing systems", UBAtc; Validity to 09/04/2013

¹¹ EN 1279-5: Glass in building - Insulating glass units - Part 5: Evaluation of conformity

2.2.2 Safety in case of fire (ER 2)

According to Commission Decision 96/603/EC, glass will be classified in category A1 and the silicone sealant in accordance with section 2.1.4 will be classified in category F.

The resistance to fire can only be assessed for the entire façade construction and shall be verified separately.

Note: A European reference fire scenario for facades has not been laid down. In some Member States the classification of "VARIO" according to EN 13501-1:2002 might not be sufficient for the use in facades. An additional assessment of "Vario" according to national provisions (e.g. on the basis of a large scale test) might be necessary to comply with Member States regulations, until the existing European classification system has been completed.

2.2.3 Hygiene, health and the environment (ER 3)

For air permeability and water tightness no performance has been determined.

Relating to "Dangerous substances" the manufacturer of the infill elements has made a declaration of compliance with the Council Directive 76/769/EEC of 27 July 1976 published with amendments in the EC Official Journal.

Note: In addition to the specific clauses relating to dangerous substances contained in this European technical approval, there may be other requirements applicable to the products falling within its scope (e.g. transposed European legislation and national laws, regulations and administrative provisions). In order to meet the provisions of the Construction Products Directive, these requirements need also to be complied with, when and where they apply.

2.2.4 Safety in use (ER 4)

2.2.4.1 General

The stability of the infill elements and their anchorage to the structure shall be verified by taking particular account of the following:

- self-weight,
- wind,
- temperature,
- exposure to climatic conditions.

Required number and distances of the U-profiles and/or screw-retaining devices shall be determined following stability verifications (2.2.4.2, 2.2.4.3 and 2.2.4.4) given hereinafter. For the structural design calculation the design concept by ECKELT GLAS GmbH (23/02/2007) may be used.

In the context of issuing this ETA the verification of impact safety of the structure was not performed.

The regulations in the Member States, in which the structural sealant glazing kit is used, shall be observed, for details see Annex B.

2.2.4.2 Glass panes

The glass panes shall be dimensioned for the actions in accordance with section 2.2.4.1. The deflection of the glass panes in the center of the pane in case of service load shall not exceed 1/100 of the smallest support expanse of the pane.

For the loading case of bond failure, when the outer pane of the insulating glass unit is held by means of emergency retaining devices exclusively, the outer pane shall be dimensioned for the total wind suction loads. The design calculation is to be done in accordance with the national provisions of the Member States, for details see Annex B. The load-bearing capacity of the emergency retaining devices is 295 N for a glass thickness of 8 mm and 358 N for a glass thickness of 10 mm. To prevent the outer pane from skidding in this loading case the chord reduction of the outer pane shall be limited to 2 mm.

2.2.4.3 Fixing by means of the screw-retaining devices

The effects of actions according to section 2.2.4.1 shall be calculated for the screw-retaining devices (2.1.6) and for the U-profile (2.1.2). For the load bearing capacity of the U-profile a maximum characteristic load of 1000 N in the area of the screw-retaining device may be used. The design calculation is to be done in accordance with the national provisions of the Member States, for details see Annex B. It shall be considered that for U-profiles with upstand the load limitation given in section 2.2.4.2 shall apply in case of bond failure. For the screw-retaining devices see section 2.1.6.

2.2.4.4 Verification of the structural bond

It shall be verified that the structural bond under the actions given in section 2.2.4.1 do not obtain any stresses exceeding the stresses approved according to ETA-03/0003. Thereafter, the structural bond with a width of 16 mm (2.1.4) can carry a load F of 2.24 kN/m. At this a global safety factor $\gamma_{tot} = 6$ is considered in accordance with ETA-03/0003.

Due to the point transmission of forces by means of the screw-retaining devices, the structural bond is not uniformly stressed by the wind suction loads, so that the following distinction of cases is to be taken into account:

1. The wind load of the outer pane is completely assigned to the point bearing and an associated effective width of the silicone sealant of $b = 140$ mm. This means:

$$(w \times A) / (n \times b) \leq F$$

w - wind suction (proportion of the exterior pane)

A - glazing area

n - number of point bearings

b - effective width for the load

F - load-bearing capacity of the structural bond

The number of retaining devices (point bearings) required can be increased up to the use of the minimum distance of retaining device of 300 mm.

2. The climate load is distributed on the remaining structural bond of silicone between the retaining devices. This means:

$$K \times A / (U - n \times b) \leq F$$

K - climate load

U - pane periphery

The design of the structural bond has to be carried out in accordance with the regulations in the Member State, in which the infill elements will be used (see Annex B).

2.2.4.5 Glass supports

The glass supports according to Annexes 3 and 3a shall be verified for the self-weight loading of the infill element in every use case.

2.2.4.6 Deflection

The deflection of the framing profiles supporting the pane edges shall not exceed - in the area of the pane edge - 1/200 of the pane edge length concerned. For pane edges of insulating glasses it shall, however, not exceed 15 mm.

2.2.5 Protection against noise

In the context of issuing this ETA the verification of performance capacities of the protection against noise was not performed. For the verification of the entire façade structure, regarding the protection against noise, the regulations of the Member States shall apply.

2.2.6 Energy economy and heat retention (ER 6)

For the verification of the entire façade structure, regarding the energy economy and thermal insulation, the regulations of the Member States shall apply.

3 Evaluation and attestation of conformity and CE marking

3.1 System of attestation of conformity

According to the decision of the European Commission of 24.06.1996 published in the Official Journal of the European Communities L 254 of 08.10.1996 the system 2+ of attestation of conformity for structural sealant glazing kit according to type I of ETAG 002-1 and the system 1 of attestation of conformity for type II of the ETAG 002-1 apply. These systems are defined in the following:

System 1: Certification of the conformity of the product by a notified body on the basis of:

- (a) Tasks for the manufacturer:
 - (1) factory production control;
 - (2) further testing of samples taken at the factory by the manufacturer in accordance with a prescribed test plan;
- (b) Tasks for the notified body:
 - (3) initial type-testing of the product;
 - (4) initial inspection of factory and of factory production control;
 - (5) continuous surveillance, assessment and approval of factory production control;

System 2+: Declaration of conformity of the product by the manufacturer on the basis of:

- (a) Tasks for the manufacturer:
 - (1) initial type-testing of the product;
 - (2) factory production control;
 - (3) testing of samples taken at the factory in accordance with a prescribed test plan.
- (b) Tasks for the notified body:
 - (4) certification of factory production control on the basis of:
 - initial inspection of factory and of factory production control;
 - continuous surveillance, assessment and approval of factory production control.

3.2 Responsibilities

To ensure that the product is in conformity with this European technical approval the following controls are required.

The manufacturer may only use the initial / raw / constituent materials stated in the technical documentation of this European technical approval.

Tasks for the assessment of conformity for system 1

	Tasks	Contents
Manufacturer	Factory production control	Permanent internal control of production; type scope, frequency and documentation of the tests are laid down in the control plan ⁷ . Involvement of a body approved for the field of structural sealant glazing systems in accordance with the control plan.
	Testing of samples taken at the factory	Testing of samples taken at the factory in accordance with a prescribed control plan.

Notified Body	Initial type-testing of the product	Execution and documentation of the tests in accordance with the control plan by an approved body.
	Initial inspection of factory and factory production control	The notified body has to verify that the factory, in particular the staff and equipment, and the factory production control, are suitable to ensure continuous and orderly manufacturing of the products in compliance with the provisions given in section 2.1 and in the Annexes of the European technical approval.
	continuous surveillance, assessment and approval of factory production control	The notified body shall perform at least twice a year a surveillance at the factory. It shall be verified that the factory production control is maintained taking into account the specified control plan.
	EC certificate of conformity	Issuing an EC certificate of conformity of the product.

Tasks for the assessment of conformity for system 2+

	Tasks	Contents
Manufacturer	Initial type-testing of the product	Execution and documentation of the tests in accordance with the control plan.
	Factory production control	Permanent internal control of production; type scope, frequency and documentation of the tests are laid down in the control plan ⁷ . Involvement of an approved body for the field of structural sealant glazing systems in accordance with the control plan.
	Testing of samples taken at the factory	Testing of samples taken at the factory in accordance with a prescribed control plan.
Notified Body	Initial inspection of factory and factory production control	The notified body has to verify that the factory, in particular the staff and equipment, and the factory production control, are suitable to ensure continuous and orderly manufacturing of the products in compliance with the provisions given in section 2.1 and in the Annexes of the European technical approval.
	continuous surveillance, assessment and approval of factory production control	The notified body shall perform at least twice a year a surveillance at the factory. It shall be verified that the factory production control is maintained taking into account the specified control plan.
	EC certificate of conformity	Granting of EC certificate for the factory production control.

The EC certificates and the results of the factory production control and the continuous surveillance shall be submitted by the notified body or the manufacturer to the Deutsches Institut für Bautechnik, on request.

In cases where the provisions of the European technical approval and its control plan are no longer fulfilled, the certificate of conformity has to be invalidated and Deutsches Institut für Bautechnik has to be informed.

3.3 CE marking

The CE marking shall be affixed on the product itself, on the label attached to it, on the packaging or on the accompanying document. The letters "CE" shall be accompanied by the following additional information:

- the name and address of the manufacturer (legal entity responsible for the manufacturer) and the manufacturing plant,
- the last two digits of the year in which the CE marking was affixed,
- the number of the EC certificate of conformity for the product (system 1),
- the number of the EC certificate for the factory production control (system 2+),
- the number of the European technical approval,
- identification of the product "VARIO".

4 Assumptions under which the fitness of the product for the intended use was favourably assessed

4.1 Manufacturing

The European technical approval is issued for the product on the basis of agreed information, deposited with Deutsches Institut für Bautechnik, which identifies the product that has been assessed and judged. Changes to the product or production process, which could result in this deposited information being incorrect, should be notified to Deutsches Institut für Bautechnik before the changes are introduced. Deutsches Institut für Bautechnik will decide whether or not such changes affect the approval and consequently the validity of the CE marking on the basis of the approval, and if so whether further assessment or alterations to the approval shall be necessary.

The infill elements may only be manufactured in plants of the company "ECKELT GLAS GmbH". The surfaces to be sealed may only be prepared in conformity with the manufacturing directives given by the sealant manufacturer. Bubbles, holes or inclusions in the structural sealant are not permissible.

4.2 Installation

The infill elements shall be fixed to the supporting structure according to the processing guidelines of the company "ECKELT GLAS GmbH" such that no restraints may occur in the elements. The installation shall be performed by experts only, which have been trained for these works by the company "ECKELT GLAS GmbH".

The system "VARIO" shall not be installed in an environment with high chloride content (e.g. indoor pools).

5 Indications to the manufacturer

5.1 Packaging, transport and storage

The manufacturer shall take suitable precautions for packaging, transport and storage to ensure that glass elements are protected against damage by, e.g. breakage, scratching, splitting or contamination.

Suitable arrangements have to be made to prevent the application of unacceptable loads to the structural seal, for example the provision of suitable racks, and to prevent exposure to water, solar radiation or significant changes of temperature, by protecting with covers.

5.2 Use, maintenance, repair

The cleaning of the façade may only be performed by using water with the addition of not more than 1 % surface-active agents without any other chemical additives and/or any aggressive cleaning methods (e.g. blast-cleaning with steam pressure).

Georg Feistel
Head of Department

beglaubigt
Herr

National provisions for glass products

Annex A

1. Provisions for the production of heat-soaked soda lime silicate safety glass (ESG-H)*

Class	Member States	Technical rule
A	Germany	Provisions for the production of heat-soaked thermally toughened soda lime silicate safety glass (ESG-H), see <i>Bauregelliste</i> ('Construction Products List') A Part 1, serial No 1.13

2. Provisions for the production of laminated safety glass with PVB foil (VSG)*

Class	Member States	Technical rule
A	Germany	Provisions for the production of laminated safety glass with PVB foil, see <i>Bauregelliste</i> ('Construction Products List') A Part 1, serial No 11.14

3. Provisions for the production of float glass (soda lime silicate glass)*

Class	Member States	Technical rule	Additional provisions
A	Germany	DIN EN 572-9 and <i>Bauregelliste</i> ('Construction Products List') A Part I, serial No 11.10	Indication of the bending tensile strength

4. Provisions for the production of thermally toughened soda lime silicate safety glass (ESG)*

Class	Member States	Technical rule	Additional provisions
A	Germany	DIN EN 12150-2 and <i>Bauregelliste</i> ('Construction Products List') A Part 1 serial No 11.12	Indication of the bending tensile strength

5. Provisions for the production of heat strengthened soda lime silicate glass (TVG)*

Class	Member States	Technical rule	Additional provisions
A	Germany	DIN EN 1863-2 and <i>allgemeine bauaufsichtliche Zulassung</i> ('National technical approval') for heat strengthened soda lime silicate glass/TVG	Indication of the bending tensile strength

* The national provisions of the Member States, not listed in this column, shall be taken into account.

National provisions for design calculation

Annex B

1. Design calculation for the loading case of bond failure*

Class	Member States	Additional provisions	Allowable values
A	Germany	Safety factor of 1.1 is to be considered for the glass panes (ESG-H) and for the emergency retaining devices	ESG-H: 109 N/mm ² Retaining devices: Glass 8 mm: 268 N Glass 10 mm: 325 N

2. Design resistance of the U-profile in the area of the screw-retaining device*

Class	Member States	Additional provisions	Allowable values
A	Germany	Global (total) safety factor of 1.15	870 N

3. Design calculation for the structural sealant*

Class	Member States	Additional provisions	Allowable values
A	Germany	Global safety factor γ_{tot}	$\gamma_{tot} = 6$

The national provisions of the Member States, not listed in this column, shall be taken into account.

Punkt 1.1 / Item 1.1

U-Profil mit Aufkantung (Nothalter) / U-profile with an upstand (safety device)

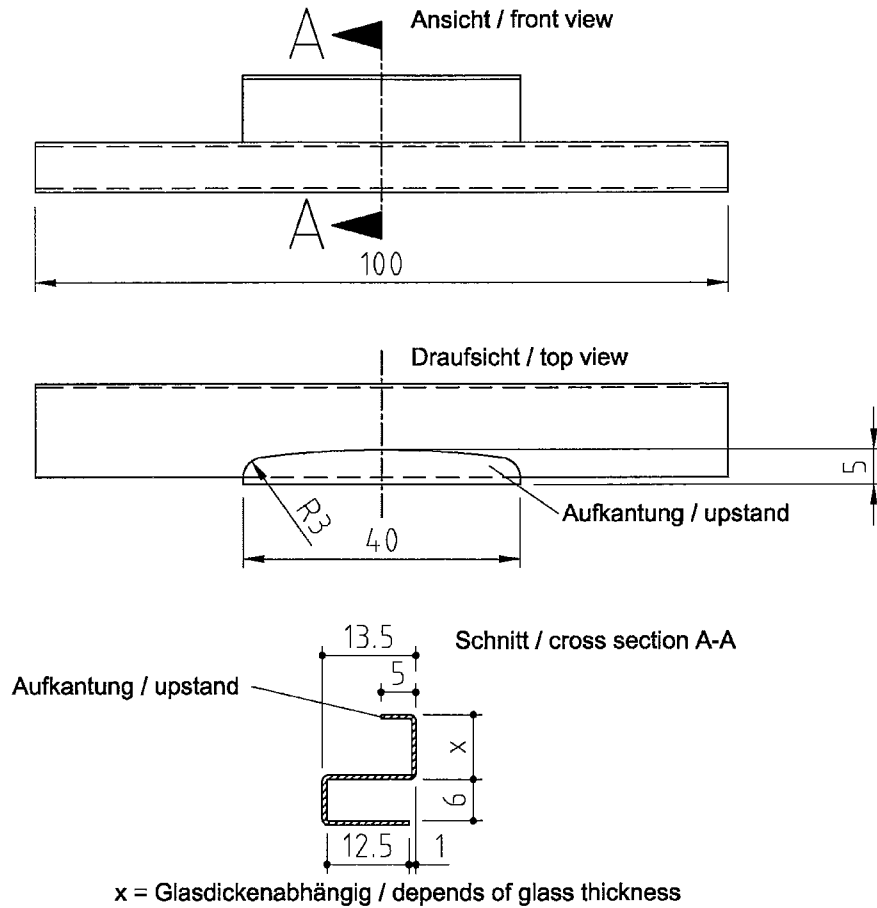

VARIO DZ

Schnitt / sectional drawing

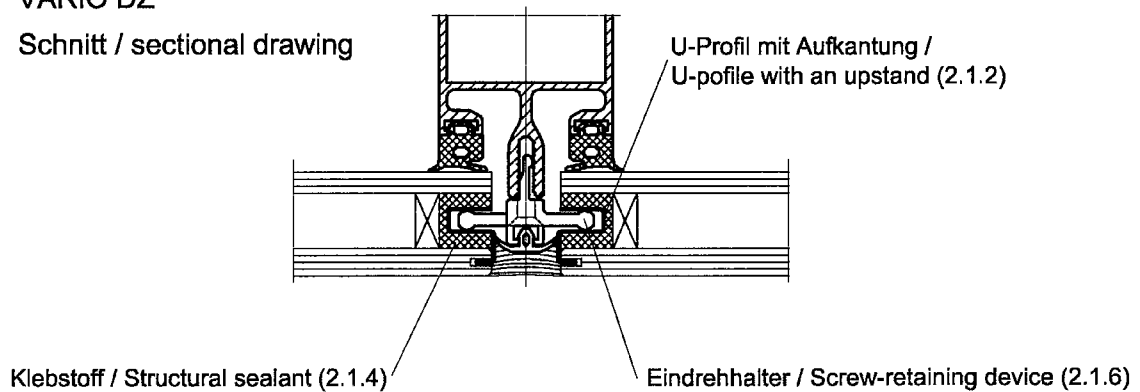

ECKELT GLAS GmbH
 Resthofstraße 18, A-4400 Steyr, AUSTRIA
 Tel: +43-7252-894-0, Fax: +43-7252-894-24
www.eckelt.at vertrieb@eckelt.at

VARIO DZ
 Mechanische Sicherung
 safety device

Annex 1
 of the European
 technical approval
ETA-10/0362

Punkt 1.1 / Item 1.1

U-Profil ohne Aufkantung / U-profile without an upstand

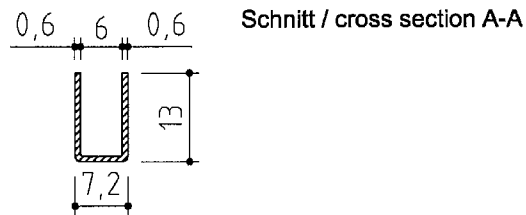
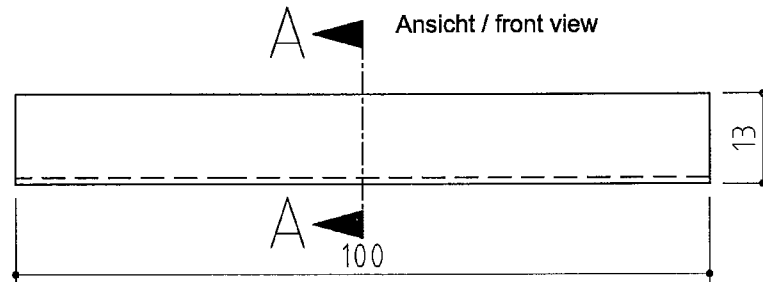

VARIO S-FOR

Schnitt / sectional drawing

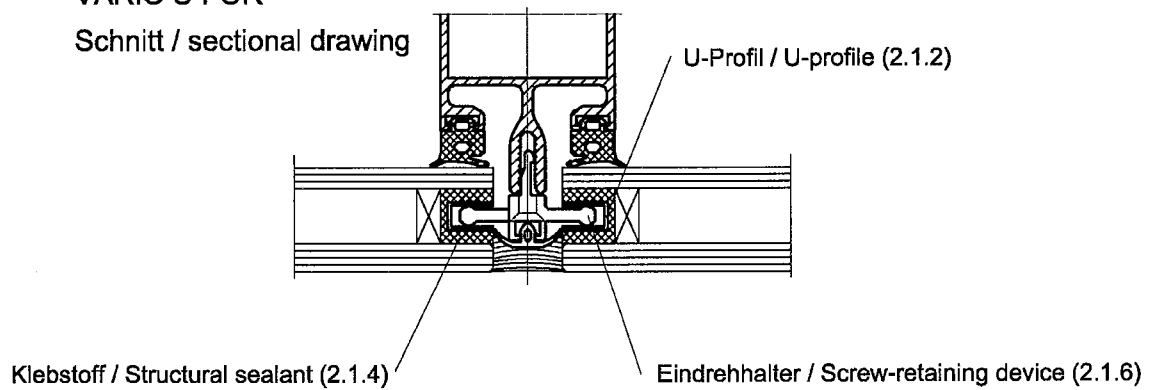

VARIO S-FOR in Deutschland nur bis zu einer Einbauhöhe von 8 m
 VARIO S-FOR in Germany only up to 8 m height



ECKELT GLAS GmbH
 Resthofstraße 18, A-4400 Steyr, AUSTRIA
 Tel: +43-7252-894-0, Fax: +43-7252-894-24
www.eckelt.at vertrieb@eckelt.at

VARIO S-FOR

Annex 1a
 of the European
 technical approval
ETA-10/0362

Punkt 2.1.1 / Item 2.1.1

Abmessungen des Glaseinschliffs / Dimensions of the glass grinding

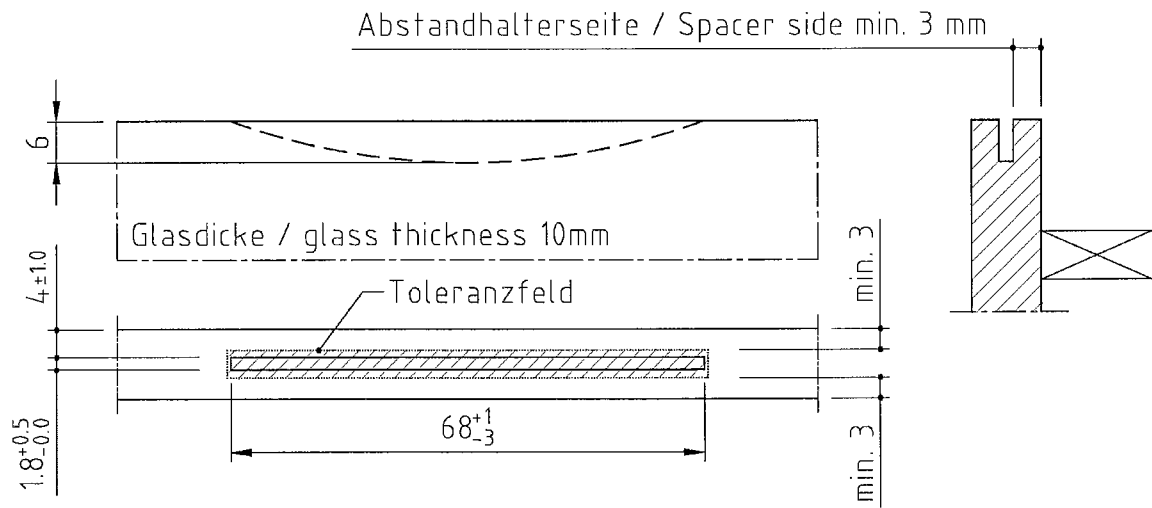
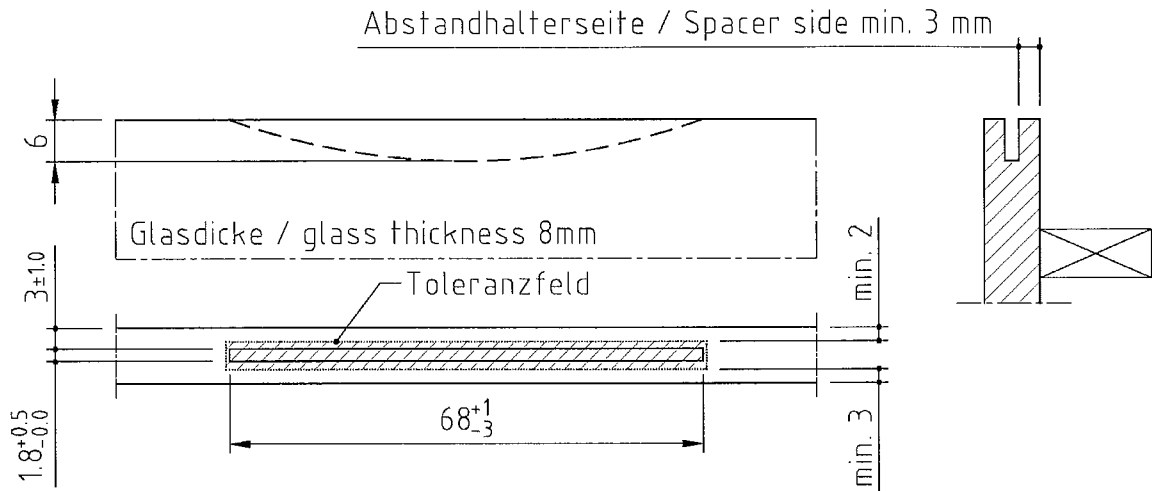

ECKELT Saint-Gobain Glass Solutions

ECKELT GLAS GmbH
 Resthofstraße 18, A-4400 Steyr, AUSTRIA
 Tel: +43-7252-894-0, Fax: +43-7252-894-24
www.eckelt.at vertrieb@eckelt.at

VARIO DZ
 Glaseinschliff / glass grinding
 8 mm, 10 mm ESG-H

Annex 2
 of the European
 technical approval
ETA-10/0362

Punkt 2.1.5 / Item 2.1.5
 Punkt 2.1.6 / Item 2.1.6

Eigengewichtsabtragung / Klotzung

Es muss sichergestellt werden, dass das Eigengewicht der Isolierglasscheibe durch die Klotzung abgetragen wird.

Im Bereich des Glaseinschnitts darf nicht geklotzt werden.

Die Klotzung muss 2/3 der Dicke der Außenscheibe erfassen.

Self weight support / setting block:

The dead weight of the insulating glass pane has to be carried by the setting blocks. Do not place setting blocks at the cut in area.

The setting block must be positioned 2/3 of the thickness of the outside pane.

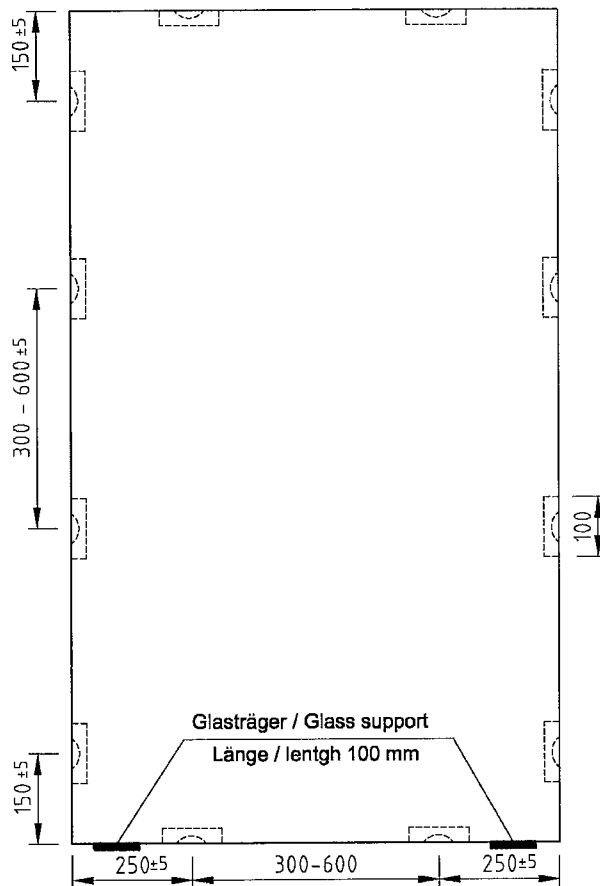
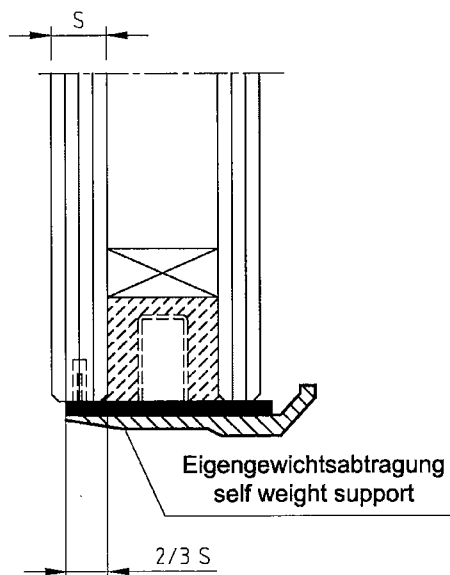

Bei Scheibenbreiten von 500 mm bis 700 mm, nur einen Halteteil einsetzen.
 For pane width 500 mm to 700 mm insert one mechanical clip only.

Über 700 mm zwei oder mehr Halteteile einsetzen, wobei der Abstand der Halteteile 300 bis 600 mm betragen soll.
 Pane widths of over 700 mm insert two or more mechanical clips, the distance between the clips should be 300 to 600 mm.

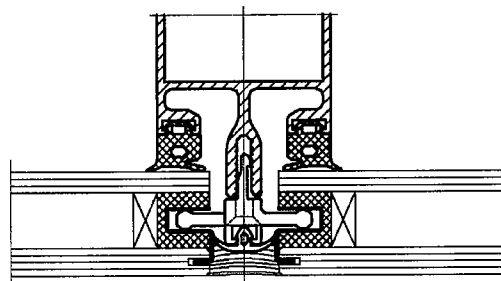

ECKELT Saint-Gobain Glass Solutions
 ECKELT GLAS GmbH
 Resthofstraße 18, A-4400 Steyr, AUSTRIA
 Tel: +43-7252-894-0, Fax: +43-7252-894-24
 www.eckelt.at vertrieb@eckelt.at

VARIO DZ
 Eigengewichtsabtragung
 self weight support

Annex 3
 of the European
 technical approval
ETA-10/0362

Punkt 2.1.5 / Item 2.1.5
 Punkt 2.1.6 / Item 2.1.6

Eigengewichtsabtragung / Klotzung

Es muss sichergestellt werden, dass das Eigengewicht der Isolierglasscheibe durch die Klotzung abgetragen wird.

Im Bereich des Glaseinschnitts darf nicht geklotzt werden.

Die Klotzung muss 2/3 der Dicke der Außenscheibe erfassen.

Self weight support / setting block:

The dead weight of the insulating glass pane has to be carried by the setting blocks. Do not place setting blocks at the cut in area.

The setting block must be positioned 2/3 of the thickness of the outside pane.

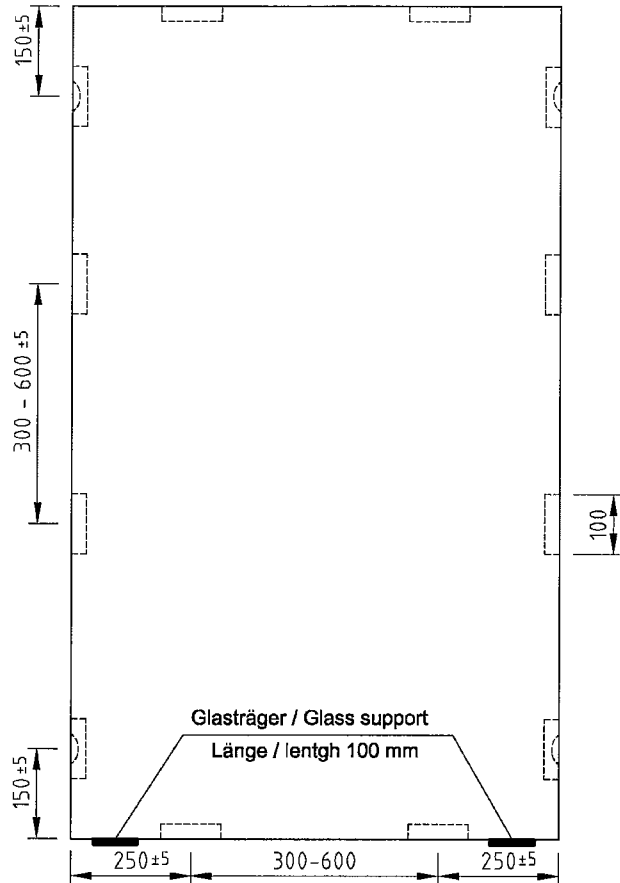
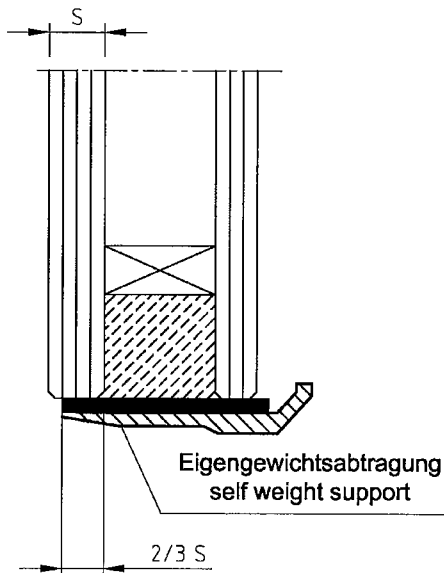

Bei Scheibenbreiten von 500 mm bis 700 mm, nur einen Halteteil einsetzen.
 For pane width 500 mm to 700 mm insert one mechanical clip only.

Über 700 mm zwei oder mehr Halteteile einsetzen, wobei der Abstand der Halteteile 300 bis 600 mm betragen soll.
 Pane widths of over 700 mm insert two or more mechanical clips, the distance between the clips should be 300 to 600 mm.

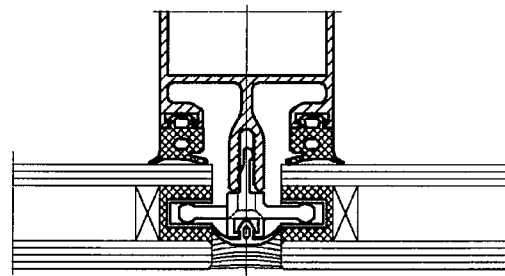

ECKELT Saint-Gobain Glass Solutions

ECKELT GLAS GmbH
 Resthofstraße 18, A-4400 Steyr, AUSTRIA
 Tel: +43-7252-894-0, Fax: +43-7252-894-24
 www.eckelt.at vertrieb@eckelt.at

VARIO S-FOR
 Eigengewichtsabtragung
 self weight support

Annex 3a
 of the European
 technical approval
ETA-10/0362