

Approval body for construction products
and types of construction

Bautechnisches Prüfamt

An institution established by the Federal and
Laender Governments



European Technical Assessment

ETA-10/0400
of 7 January 2016

English translation prepared by DIBt - Original version in German language

General Part

Technical Assessment Body issuing the
European Technical Assessment:

Deutsches Institut für Bautechnik

Trade name of the construction product

Spiral stair system "Thumm"

Product family
to which the construction product belongs

Spiral stair with steps made of natural stone or artificial
stone for use as an indoor stair in buildings

Manufacturer

Thumm & Co. Maschinenbau GmbH
In der Au 14
72622 Nürtingen
DEUTSCHLAND

Manufacturing plant

Thumm & Co. Werk 1-20

This European Technical Assessment
contains

15 pages including 3 annexes which form an integral part
of this assessment

This European Technical Assessment is
issued in accordance with Regulation (EU)
No 305/2011, on the basis of

Guideline for European technical approval of
"Prefabricated stair kits", ETAG 008 Part 1: "Prefabricated
stair kits in general (excluding severe climatic
conditions)", Januar 2002,
used as European Assessment Document (EAD)
according to Article 66 Paragraph 3 of Regulation (EU)
No 305/2011.

**European Technical Assessment
ETA-10/0400**

Page 2 of 15 | 7 January 2016

English translation prepared by DIBt

The European Technical Assessment is issued by the Technical Assessment Body in its official language. Translations of this European Technical Assessment in other languages shall fully correspond to the original issued document and shall be identified as such.

Communication of this European Technical Assessment, including transmission by electronic means, shall be in full. However, partial reproduction may only be made with the written consent of the issuing Technical Assessment Body. Any partial reproduction shall be identified as such.

This European Technical Assessment may be withdrawn by the issuing Technical Assessment Body, in particular pursuant to information by the Commission in accordance with Article 25(3) of Regulation (EU) No 305/2011.

Specific Part

1 Technical description of the product

The Spiral stair system "Thumm" is a prefabricated stair system which consists of steps, landings, a newel and load-bearing bolts.

The steps and landings are made of natural stone or artificial stone (reaction resin bonded). They consist of two plates that are glued together by an intermediate GFK-layer.

The steps are stressed together between spindle pots with a tensioning bolt (newel). On the outside the steps are connected which each other by load-bearing bolts. Spindle pots, tensioning bolt and load-bearing bolts are made of steel.

The product description is given in Annex A.

2 Specification of the intended use in accordance with the applicable European Assessment Document

The performances given in Section 3 are only valid if the stair is used in compliance with the specifications and conditions given in Annex B.

The verification and assessment methods on which this European Technical Assessment is based lead to the assumption of a working life of the stair of at least 50 years. The indications given on the working life cannot be interpreted as a guarantee given by the producer, but are to be regarded only as a means for choosing the right products in relation to the expected economically reasonable working life of the works.

3 Performance of the product and references to the methods used for its assessment

3.1 Mechanical resistance and stability (BWR 1)

Essential characteristic	Performance
Load-bearing capacity	See Annex C2
Load/displacement behaviour	See Annex C2
Vibration behaviour	First natural frequency: $f_1 \geq 5$ Hz (inclusive a single mass of 100 kg) Deflection under a single load $F = 1$ kN: $w \leq 5$ mm
Prevention of progressive collapse	Failure of individual components of the stair does not lead to a progressive collapse of the complete stair
Residual load-bearing capacity	Local material failure does not lead to an abrupt total loss of load-bearing capacity of the stair.
Long-term behaviour	Load-bearing capacity is ensured under an appropriate use and maintenance over the indicated working life
Resistance to earthquakes	No performance assessed
Resistance of fixings	See Annex C3

3.2 Safety in case of fire (BWR 2)

Essential characteristic	Performance
Reaction to fire	See Annex A5
Fire resistance	No performance assessed

3.3 Hygiene, health and the environment (BWR 3)

Regarding dangerous substances there may be requirements (e.g. transposed European legislation and national laws, regulations and administrative provisions) applicable to the products falling within the scope of this European Technical Assessment. In order to meet the provisions of Regulation (EU) No 305/2011, these requirements need also to be complied with, when and where they apply.

3.4 Safety in use (BWR 4)

Essential characteristic	Performance
Geometry	See Annex C1
Slipperiness	No performance assessed
Equipment of the stair for a safe use	No performance assessed
Safe breakage of stair components	No brittle failure of individual stair components
Impact resistance	Verified for steps made of natural stone or artificial stone up to a fall height of a steel weight (50 kg) of 200 mm

3.5 General aspects

Essential characteristic	Performance
Resistance to deterioration caused by physical, chemical and biological agents	Adequate resistance for the intended use under an appropriate use and maintenance
Finishes and surface layers	Surfaces of components from natural stone and artificial stone (steps) non-treated or polished

4 Assessment and verification of constancy of performance (AVCP) system applied, with reference to its legal base

In accordance with guideline for European technical approval ETAG 008, January 2002, used as European Assessment Document (EAD) according to Article 66 Paragraph 3 of Regulation (EU) No 305/2011, the applicable European legal act is: 99/89/EC

The System to be applied is: 2+

In addition, with regard to reaction to fire for products covered by the guideline for European technical approval ETAG 008, January 2002, used as European Assessment Document (EAD) according to Article 66 Paragraph 3 of Regulation (EU) No 305/2011, the applicable European legal act is: 2001/596/EC

The System to be applied is: 4

English translation prepared by DIBt

5 Technical details necessary for the implementation of the AVCP system, as provided for in the applicable European Assessment Document

Technical details necessary for the implementation of the AVCP system are laid down in the control plan deposited at Deutsches Institut für Bautechnik.

Issued in Berlin on 7 January 2016 by Deutsches Institut für Bautechnik

Andreas Kummerow
p. p. Head of Department

beglaubigt:
Wittstock

Plan view

- Type I, II $\varnothing \leq 1600$ mm
- Type III, IV $\varnothing \leq 1800$ mm
- Type V, VI $\varnothing \leq 2000$ mm
- Type VII $\varnothing \leq 2250$ mm
- Type VIII $\varnothing \leq 2500$ mm

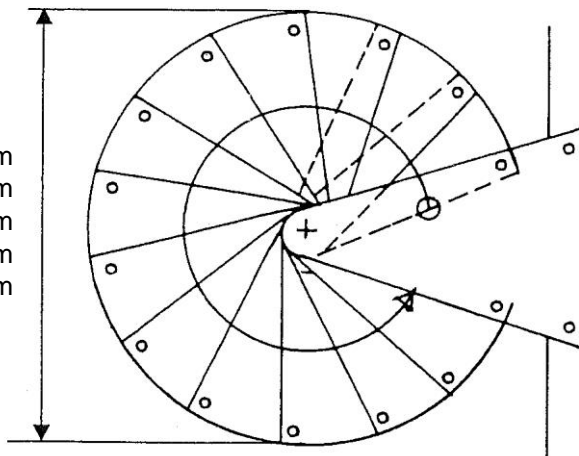

walking line is exemplified, position may be chosen freely within the walking zone, walking zone is 20 % of the clear width of the stair in the middle of the stair

Front view

≤ 3300 mm
 ≤ 18 rises

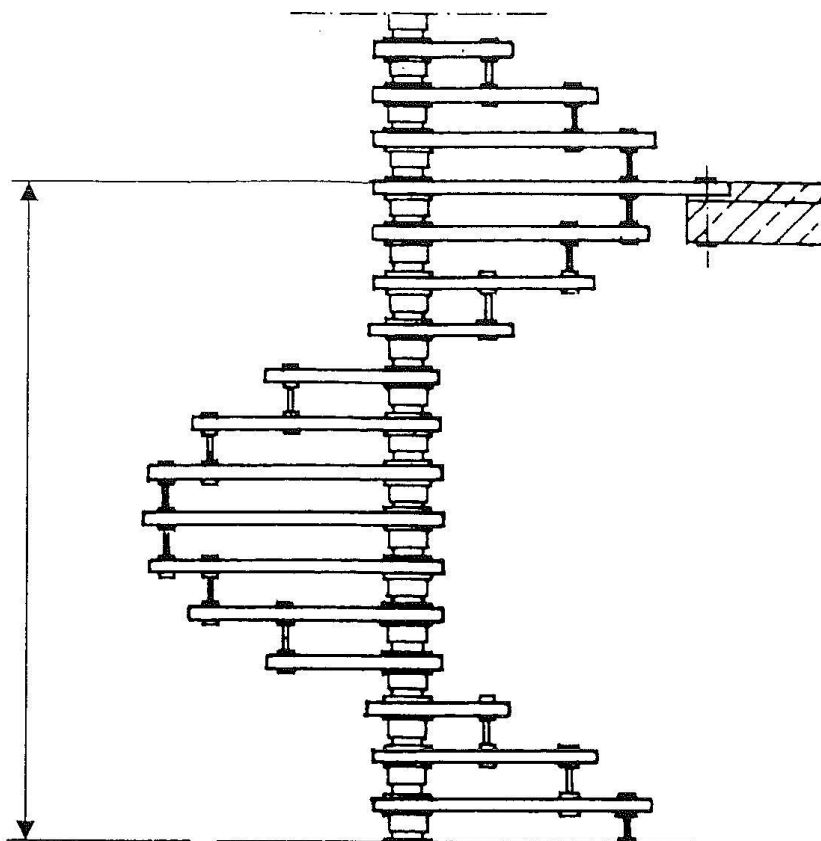

Spiral stair system "Thumm"

Product and intended use

Annex A1

Step

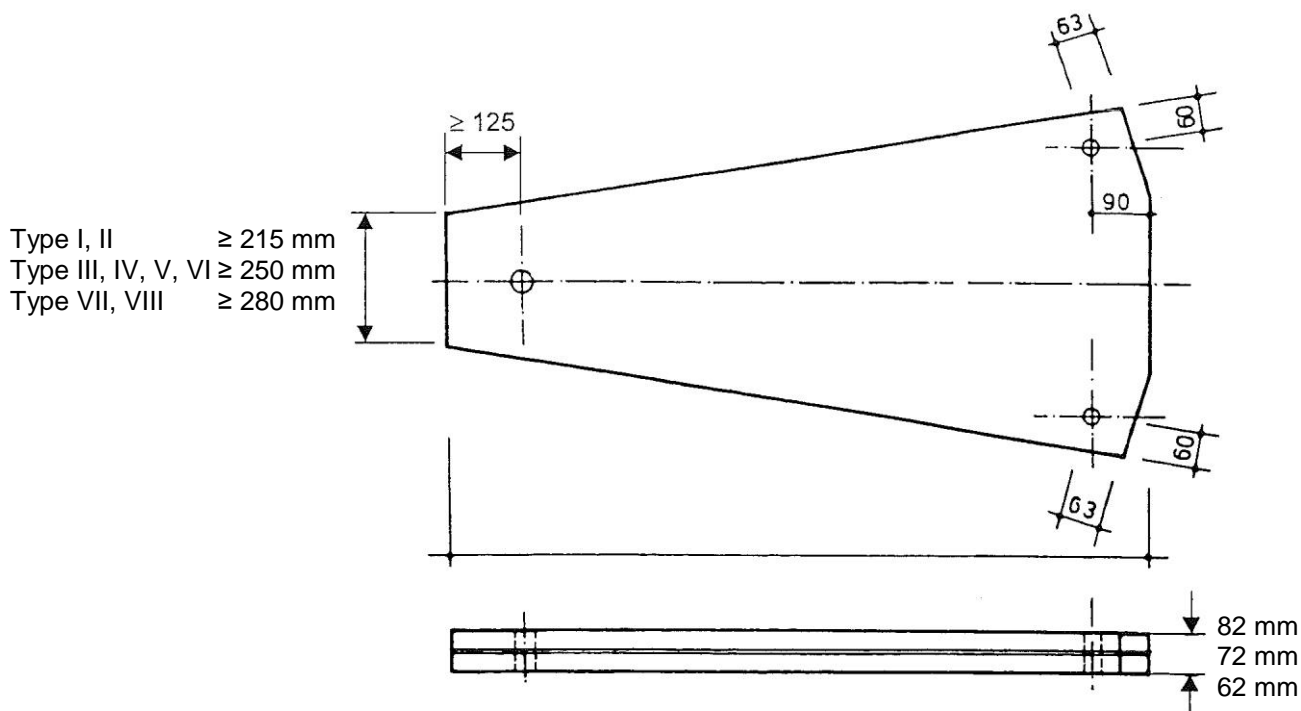

Landing

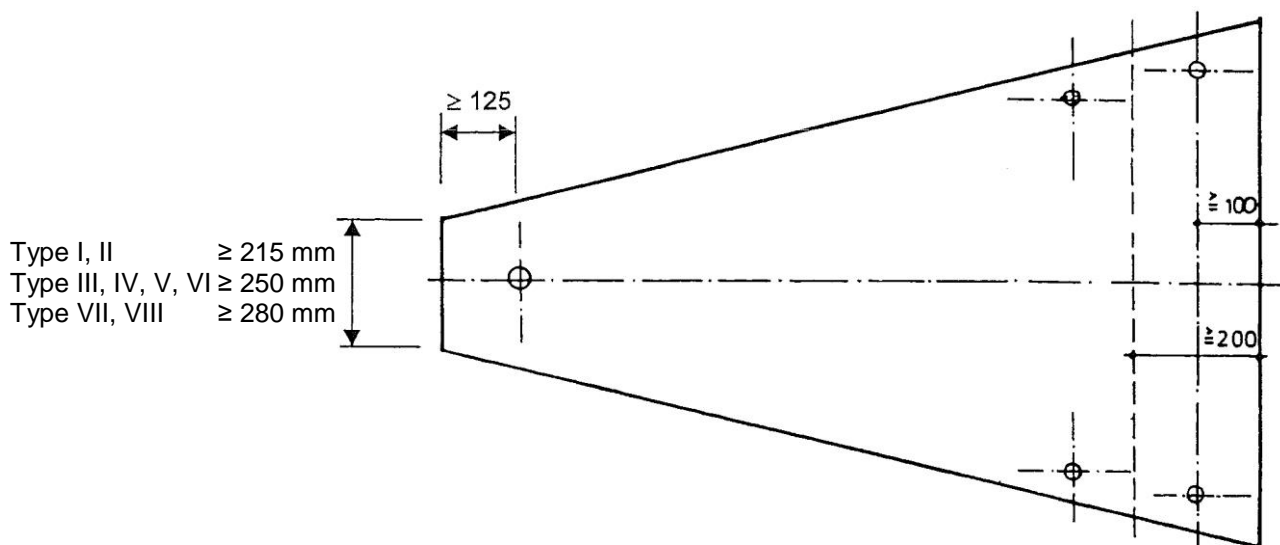

all dimensions in mm

Spiral stair system "Thumm"

Annex A2

Step and landing

Load-bearing bolts

Type IA

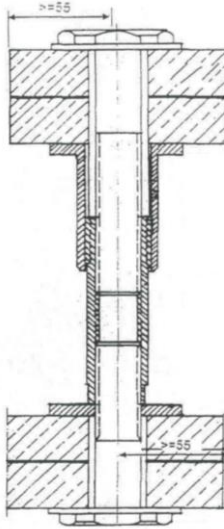

Type IIA

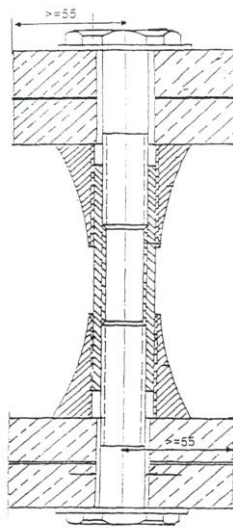

Type III

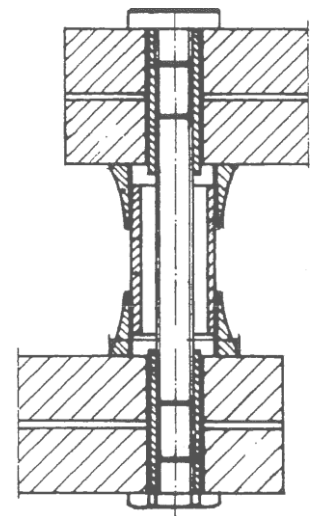

Type IB

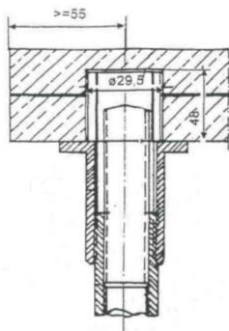

Type IIB

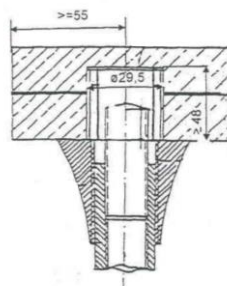

dimensions in mm

More details according to technical documentation

Spiral stair system "Thumm"

Load-bearing bolts

Annex A3

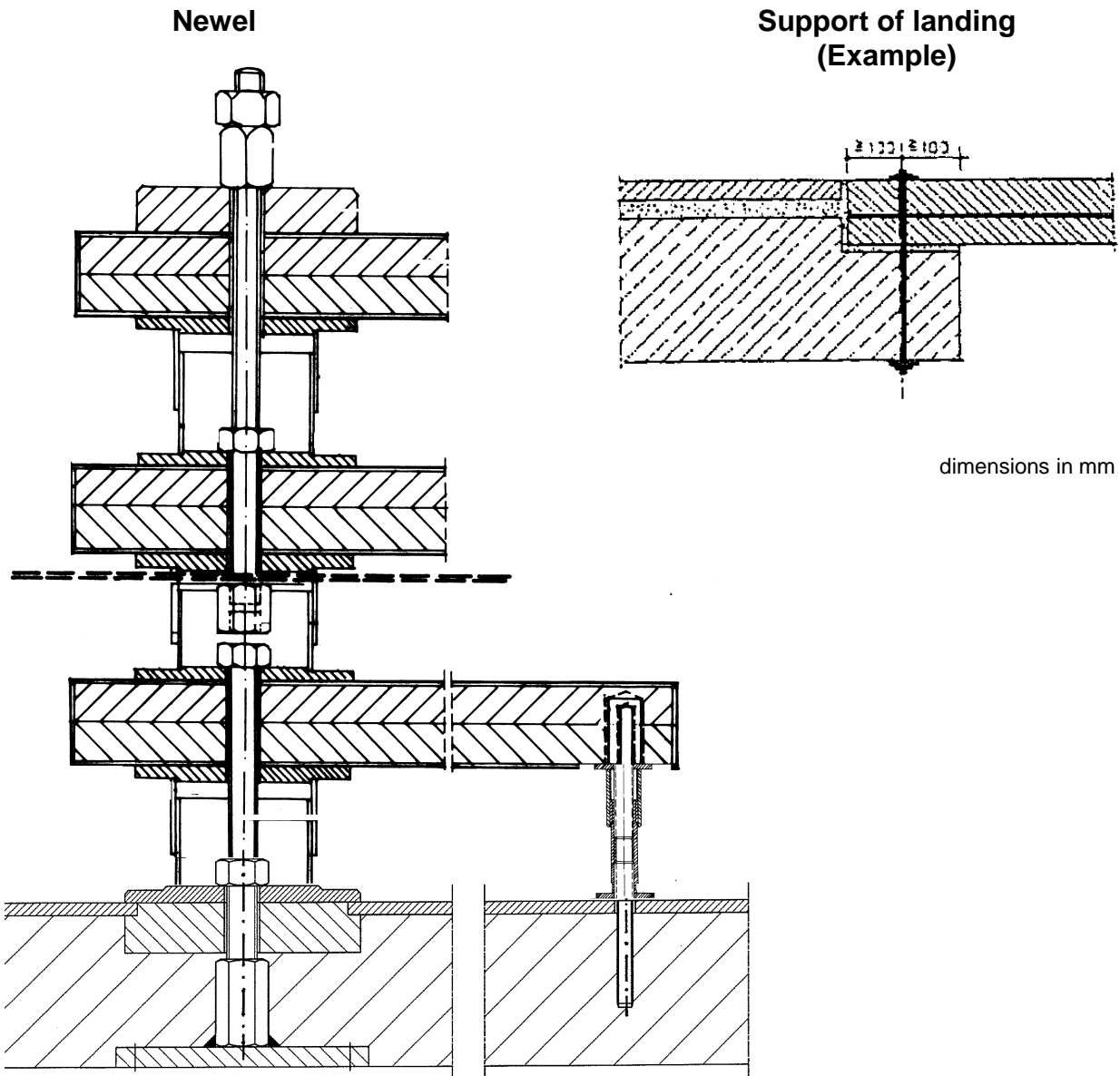

Spiral stair system "Thumm"

Newel,
Support of landings

Annex A4

Table 1: Characteristic values of materials of relevant stair components

component of stair		material	characteristic values (minimum values)				
components made of natural stone and artificial stone			$E_{0,mean}$	G_{mean}	$f_{m,k}$	$f_{v,k}$	$\gamma_M^{1)}$
			[N/mm ²]	[N/mm ²]	[N/mm ²]	[N/mm ²]	[-]
Steps, landings	resistance class I	45000	15000	6.25	6.25	1.8 ³⁾	
	resistance class II			7.50	7.50		
	resistance class III			8.75	8.75		
	resistance class IV			10.00	10.00	1.6 ³⁾	
	resistance class V			11.25	11.25		
	resistance class VI			12.50	12.50		
components made of steel			$E_{0,mean}$	G_{mean}	$f_{y,k}$	$f_{u,k}$	$\gamma_M^{1)}$
			[N/mm ²]	[N/mm ²]	[N/mm ²]	[N/mm ²]	[-]
System fasteners	steel	210000	81000	240 ²⁾	400 ²⁾	1.1	
Distance sleeve	GD-Al Si 8 Cu 3	70000	27000	160	240	1.1	
	steel	210000	81000	240 ²⁾	400 ²⁾	1.1	
Spindle pots, head plate, foot plate	steel	210000	81000	360	510	1.1	
Tensioning bolt and nuts	steel	210000	81000	900	1000	1.1	

1) recommended partial safety factor, in absence of other national regulations

2) values for load-bearing bolt type I and II, load-bearing bolt type III according to technical documentation

3) natural stone : $\gamma_M = 1,8$; artificial stone : $\gamma_M = 1,6$

Table 2: Minimum dimensions of relevant stair components and reaction to fire

component	material	dimension		Value ¹⁾	reaction to fire
Steps, landings	Natural stone	thickness	[mm]	62 ²⁾	A1
	Artificial stone (reaction resin bonded)	thickness	[mm]	62 ²⁾	F (no performance determined – NPD)
System fastener	steel	diameter	[mm]	14	A1
Distance sleeves	GD-Al Si 8 Cu 3, steel	Inner diameter	[mm]	14	A1
newel	Steel pipe	diameter	[inch]	3 ½	A1
	Tensioning bolt	diameter	[mm]	24	A1

1) minimum value, required values depending on the type of stair according to Table 3,

more details according to technical documentation

2) two plates (minimum thickness 30 mm) and intermediate GFK-layer (thickness 2 mm)

Spiral stair system "Thumm"

Characteristic values of materials,
Minimum dimensions of relevant stair components and reaction to fire

Annex A5

Specification of intended use (Part 1)

Intended use:

- European Technical Assessment applies for a construction system.
- For the specific case of use the corresponding type of stair is manufactured within the context of the values defined in the European Technical Assessment.
- Values of this ETA apply to all types of stairs; the real dimensions follow in accordance with the relevant case of use.

Stair subject to:

- Static or quasi-static loads

Use conditions:

- Indoor stair
- Air temperatures between +5 °C and +30 °C
- Relative air humidity between 30 % and 70 %
- According to the individual requirements handrail and barrier may be attached to the stair optionally.
Conditions for possible barrier/handrail:
 - Dead load ≤ 0.15 kN/m
 - Height ≤ 1.00 m
 - Distance of baluster ≤ 0.85 m

Design:

- Design of the stair according to the annexes and the technical documentation to this European Technical Assessment
- Fastening of the stair to the construction works according to the annexes and the technical documentation to this European Technical Assessment
- Verification of the transmission of loads to the construction works by the civil engineer responsible for the construction works
- Load-bearing capacity at ultimate limit state:

$$q_k \cdot \gamma_Q \leq q_{Rk} / \gamma_M$$

$$Q_k \cdot \gamma_Q \leq Q_{Rk} / \gamma_M$$

$$h_k \cdot \gamma_Q \cdot \psi_0 \leq h_{Rk} / \gamma_M$$

with

q_{Rk}, Q_{Rk}, h_{Rk} : characteristic values of resistance; see Table 5

γ_M : recommended material partial safety factor; see Table 5

q_k, Q_k, h_k : characteristic values of imposed loads according to EN 1991-1-1:2010-12

$\gamma_Q = 1.5$: recommended partial safety factor, in absence of other national regulations

$\psi_0 = 0.7$: recommended combination factor, in absence of other national regulations

- Maximum characteristic values of imposed loads under consideration of the partial factors mentioned above; see Table 7

Spiral stair system "Thumm"

Specification of intended use (Part 1)

Annex B1

Specification of intended use (Part 2)

Installation:

- Installation by personnel appropriately trained and authorized by the holder of the approval by means of the technical documentation of this European Technical Assessment
- Installation only in the way as specified in the technical documentation of this European Technical Assessment
- Sufficient support of the stair when assembling
- Installation of stair components without imposed deformations
- installation of steps without significant defects and cracks
- bolted connections are protected such that they will not be loosened by vibrations
- depending on the type of stair the nuts and the couplings of the tensioning bolt have to be tighten with the torque moment according to Annex C1, Table 3

Indications to the manufacturer:

- Ensure that all persons involved will be appropriately informed about the specific conditions according to sections 1 and 2 (including the annexes to which reference is being made as well as the not confidential parts of the technical documentation deposited to this European Technical Assessment)
- Instructions for use should provide information as to use, maintenance and repair of the stair

Spiral stair system "Thumm"

Specification of intended use (Part 2)

Annex B2

Table 3: Dimensions of relevant stair components und required resistance classes of steps according to Annex A5, Table 1 depend on the type of stair

Type of stair		I	II	III	IV	V	VI	VII	VIII
Diameter of stair	[mm]	1600	1600	1800	1800	2000	2000	2250	2500
Thickness of steps	[mm]	62	72	72	82	82	82	82	82
Width of Steps (inner side)	[mm]	215	215	250	250	250	250	280	280
Type of load-bearing bolt	[-]	I, II	I, II	I, II	I, II	III	III	III	III
Resistance class natural stone	[-]	III	II	IV	III	V	II	IV	VI
Resistance class artificial stone	[-]	II	II	III	II	IV	II	III	V
Diameter of newel	[inch]	3 ½	3 ½	5	5	5	8	8	8
Diameter of head and foot plate	[mm]	160	160	187	187	187	240	240	240
Diameter of tensioning bolt	[mm]	24	24	24	24	24	30	30	30
Pre-stressing moment	[Nm]	400	400	510	510	764	707	825	1131
Pre-stressing force	[kN]	110	110	140	140	210	150	175	240

Table 4: Geometry

designation		dimension	
		minimum	maximum
going step on walking line ¹⁾	[mm]	210	290 ²⁾
rise of the stairs ¹⁾	[mm]	140 ²⁾	220
pitch of the walking line ¹⁾	[°]	21	45
overlap of the steps	[mm]	110	- ³⁾
number of rises	[-]	3	18
openings between consecutive steps	[mm]	- ³⁾	158
clear width of stairs	[mm]	645	1130
Clear height between floors	[mm]	- ³⁾	3300
length of the flight	[mm]	- ³⁾	4930
Thickness of steps	[mm]	62	82

¹⁾ values are constant within one flight

²⁾ tolerance between nominal value and actual value = ± 5 mm

³⁾ not relevant

- 1 going
- 2 rise
- 3 overlap
- 4 opening between consecutive steps
- 5 length of the flight
- 6 thickness of steps

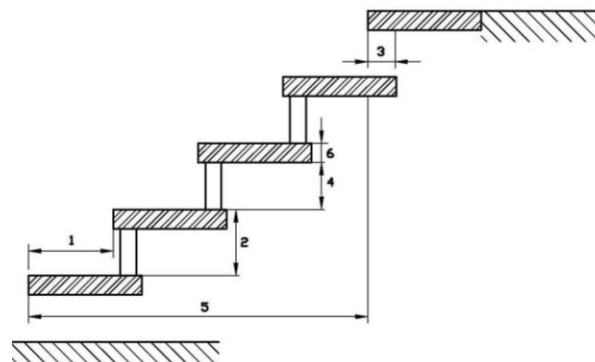

Spiral stair system "Thumm"

Dimensions of relevant stair components,
Geometry of the stair

Annex C1

Table 5: Load-bearing capacity - Characteristic values of resistance

Component of stair	Type of loading	Characteristic values of resistance			γ_M ¹⁾
Step (natural stone)	Vertical variable uniformly distributed load	$q_{R,k}$	[kN/m ²]	8.10	1.8
	Vertical variable single load	$Q_{R,k}$	[kN]	5.40	
	Horizontal variable uniformly distributed load on barrier	$h_{R,k}$	[kN/m]	0.95	
Step (artificial stone)	Vertical variable uniformly distributed load	$q_{R,k}$	[kN/m ²]	7.20	1.6
	Vertical variable single load	$Q_{R,k}$	[kN]	4.80	
	Horizontal variable uniformly distributed load on barrier	$h_{R,k}$	[kN/m]	0.84	
Newel	Vertical variable uniformly distributed load	$q_{R,k}$	[kN/m ²]	4.95	1.1
	Vertical variable single load	$Q_{R,k}$	[kN]	3.30	
	Horizontal variable uniformly distributed load on barrier	$h_{R,k}$	[kN/m]	0.58	

¹⁾ Recommended partial safety factor, in absence of other national regulations

Table 6: Deflections under loading

Deflection of the step under single point load			
Single load	Q_k	[kN]	2.0
Clear width of the stair	L	[mm]	1130
Deflection related to the clear width of the stair	w	[-]	≤ L/200

Table 7: Imposed loads

Type of loading	Imposed loads		
Vertical variable uniformly distributed load	q_k	[kN/m ²]	3.0
Vertical variable single load	Q_k	[kN]	2.0
Horizontal variable uniformly distributed load on barrier	h_k	[kN/m]	0.5

Spiral stair system "Thumm"

Load-bearing capacity - Characteristic values of resistance,
Deflections under loading,
Imposed loads

Annex C2

Table 8: Design loads for transmission of the loads to the construction works

Type of stair			I	II	III	IV	V	VI	VII	VIII
Support of newel	x = y	[kN]	± 0,6	± 0,7	± 0,8	± 1,0	± 2,5	± 2,0	± 2,0	± 3,5
Support of newel	one -storeyed	z	23,9	25,5	30,5	32,4	43,3	47,0	53,0	59,2
	two-storeyed	z	47,8	51,0	61,0	64,8	86,6	94,0	106,0	118,4
	three-storeyed	z	71,7	76,5	91,5	97,2	129,9	141,0	159,0	177,6
Support of landing	z	[kN]	2,8	3,0	3,6	3,7	6,5	5,0	5,5	6,5
Support of landing at the top	x	[kN]	± 0,8	± 1,1	± 1,2	± 1,5	± 3,0	± 2,0	± 2,0	± 3,5
	y	[kN]	± 0,3	± 0,4	± 0,5	± 0,5	± 3,0	± 2,0	± 2,0	± 2,5
Support of intermediate landings	x	[kN]	± 1,6	± 2,2	± 2,4	± 3,0	± 6,0	± 4,0	± 4,0	± 7,0
	y	[kN]	± 0,6	± 0,8	± 1,0	± 1,2	± 6,0	± 4,0	± 4,0	± 5,0
Support of load-bearing bolt	z	[kN]	2,9	3,0	3,6	3,7	4,1	3,0	3,0	4,3
	x = y	[kN]	0	0	0	0	± 0,8	± 0,6	± 0,7	± 1,1

Support of landing

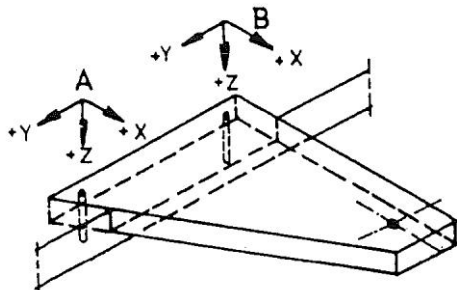

Spiral stair system "Thumm"

Design loads for transmission of the loads to the construction works

Annex C3