

Approval body for construction products  
and types of construction

Bautechnisches Prüfamt

An institution established by the Federal and  
Laender Governments



## European Technical Assessment

ETA-17/0364  
of 12 January 2018

English translation prepared by DIBt - Original version in German language

### General Part

Technical Assessment Body issuing the  
European Technical Assessment:

Deutsches Institut für Bautechnik

Trade name of the construction product

PYROCOAT ASX

Product family  
to which the construction product belongs

Ablative fire stopping product used in penetration seals

Manufacturer

OBO BETTERMANN GmbH & Co. KG  
Hüingser Ring 52  
58710 Menden  
DEUTSCHLAND

Manufacturing plant

Herstellwerk S

This European Technical Assessment  
contains

7 pages including 3 annexes which form an integral part  
of this assessment

This European Technical Assessment is  
issued in accordance with Regulation (EU)  
No 305/2011, on the basis of

EAD 350454-00-1104

**European Technical Assessment**

**ETA-17/0364**

English translation prepared by DIBt

Page 2 of 7 | 12 January 2018

The European Technical Assessment is issued by the Technical Assessment Body in its official language. Translations of this European Technical Assessment in other languages shall fully correspond to the original issued document and shall be identified as such.

Communication of this European Technical Assessment, including transmission by electronic means, shall be in full. However, partial reproduction may only be made with the written consent of the issuing Technical Assessment Body. Any partial reproduction shall be identified as such.

This European Technical Assessment may be withdrawn by the issuing Technical Assessment Body, in particular pursuant to information by the Commission in accordance with Article 25(3) of Regulation (EU) No 305/2011.

## Specific Part

### 1 Technical description of the product

The construction product "PROCOAT ASX" is an ablative fire stopping product. It is provided in the form of a white or grey liquid.

In case of fire, the construction product forms a protective layer on the surfaces to be protected. The protective layer either consumes energy or releases matter through chemical or physical processes. The protective layer thus prevents the passage of heat, flames and/or smoke.

A detailed technical description and fire safety related performance criteria in relation to the construction product are given in Annex 1.

#### NOTE:

The characteristics listed are suitable both for identifying the construction product as well as for performing the manufacturer's factory production control.

### 2 Specification of the intended use in accordance with the applicable European Assessment Document

The construction product "PYROCOAT ASX" is intended for use as a component with a fire protection effect in penetration seals that are subject to fire safety requirements. In the event of fire, its reactive effect helps prevent the passage of heat and the spread of fire. The construction product "PYROCOAT ASX" is intended for use in penetration seals.

Construction products for penetration seals are used to seal openings in fire-resistant floors and walls, which are penetrated by services.

This ETA served to verify the resistance to fire of penetration seals consisting of the products listed in Annex 1.

Their function is to preserve the walls' or floors' resistance to fire in the area of openings where services were fed through.

The construction product "PYROCOAT ASX" may be used for penetration seals intended for outdoor use (rain, UV light, frost; use category type X).

The test and assessment methods on which this European Technical Assessment is based, lead to the assumption of working life of the construction product "PYROCOAT ASX" of at least 10 years in final use.

The indications given on the working life cannot be interpreted as a guarantee given by the producer, but are to be regarded only as a means for choosing the right products in relation to the expected economically reasonable working life of the works.

The performance data in Section 3 relates only to the penetration seals tested as part of this assessment (e.g. regarding the design and arrangement of the penetration seal components and the type and position of the services).

English translation prepared by DIBt

### 3 Performance of the product and references to the methods used for its assessment

#### 3.1 Safety in case of fire (BWR 2)

Essential characteristic	Performance
Reaction to fire	Class E in accordance with EN 13501-1
Resistance to fire of a penetration seal containing the product	The resistance to fire depends on the design and installation of the penetration seal and on the other components forming the penetration seal. More details on the tested penetration seals and the related fire resistance classes are given in Annexes 1 to 3.

#### 3.2 Hygiene, health and the environment (BWR 3)

Content and release of dangerous substances	No dangerous substances <sup>1</sup>
---	--------------------------------------

### 4 Assessment and verification of constancy of performance (AVCP) system applied, with reference to its legal base

In accordance with EAD No. 350454-000-1104 the applicable European legal act is: 1999/454/EC.

The system to be applied is: system 1.

### 5 Technical details necessary for the implementation of the AVCP system, as provided for in the applicable EAD

Technical details necessary for the implementation of the AVCP system are laid down in the test plan (control plan) deposited with Deutsches Institut für Bautechnik.

Issued in Berlin on 12. Januar 2018 by Deutsches Institut für Bautechnik

Prof. Gunter Hoppe  
Head of Department

*beglaubigt:*  
Bisemeier

<sup>1</sup> In accordance with Regulation (EC) No 1272/2008 of the European Parliament and the European Council of 16 December 2008 (published in the Official Journal of the European Communities L 353 of 31 December 2008, p. 1)

The factory manufactured construction product "PYROCOAT ASX" is an ablative fire stopping product. It is provided in the form of a white or grey liquid.

**Properties and performances criteria of the construction product "PYROCOAT ASX"\***

	Property/ Performance criteria	Parameter	Test method
1	Density	1410 g/l ± 70 g/l	EN ISO 2811-1
2	Nonvolatile components	66,0 % bis 86,0%	EN ISO 3251
3	Loss mass on heating	38,0 % bis 48,0 %	EN ISO 3451-1/EOTA TR 24 (2009) on 400°C over 30 Minutes
4	LOI	55,0 % ± 3 %	ISO 4589 Sample thickness ca. 1,5 mm
5	Flexibility of the coating	≥ 5 mm	EN ISO 1519 Sample thickness ca. 1,5 mm
6	Fire behavior	Klasse E	EN ISO 11925-2

The properties listed can be used both for the identification of the construction product and for the implementation of the factory production control of the manufacturer.

Implementation details for the factory production control are included in the inspection plan.

\* The composition of the materials is deposited at DIBt.

**Description of the additional components of the tested sealings**

Soffit of the opening	Gypsum plasterboard acc. to EN 520, Typ F thickness: 12,5 mm Classification of fire behavior acc. to EN 13501-1: Class A1
Sealing of the residual opening	Loose mineral wool "RL", Deutsche Rockwool Mineralwoll GmbH, 45866 Gladbeck, Germany; EN 14303 Classification of fire behavior acc. to EN 13501-1: Class A1

PYROCOAT ASX

Description of the construction products, properties and performances

Annex 1

**Performances of tested penetration seals, comprising the construction product "PYROCOAT ASX"**

	Essential requirement	Test method	Construction of the sample	Performance acc. to EN 13501-2
1	Resistance to fire	EN 1366-3	100 mm thick flexible wall; design and layout of the penetration seal according to Annex 3*	EI 60
2	Resistance to fire	EN 1366-3	125 mm thick rigid floor; design and layout of the penetration seal according to Annex 3*	EI 90

\* Illustrations without guarantee for completeness

The use of the construction product "PYROCOAT ASX" in penetration seals shall be in accordance with national requirements for planning, design and execution and in accordance with the installation instruction of the manufacturer.

The tested/ illustrated seals are only examples for the use.

PYROCOAT ASX

Description of the construction products, properties and performances

Annex 2

**wall installation**

rectangular opening 350 x 150 ( w x h )

coating with  
"PYROCOAT ASX",  
thickness 3 mm

cable  
first support in  
front of the wall

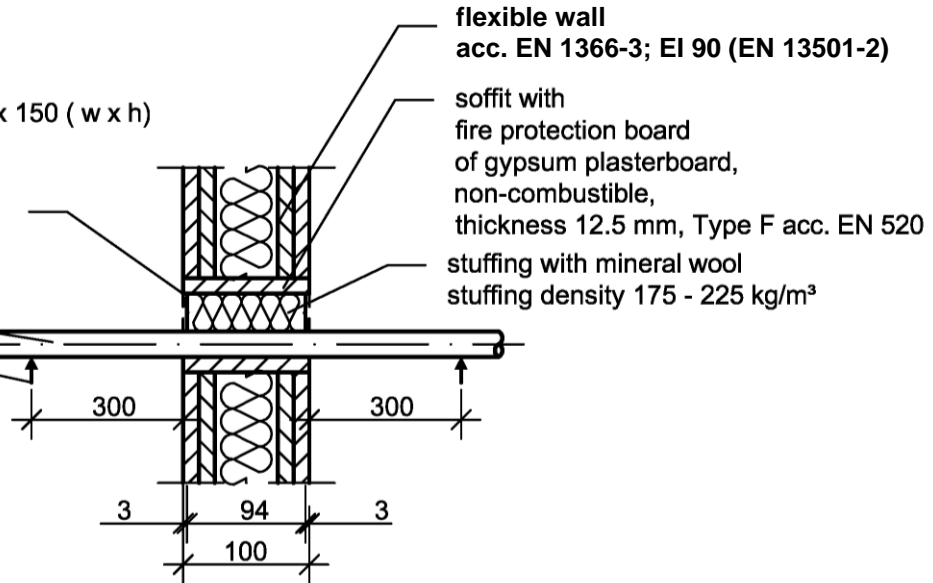

**floor installation**

rectangular opening 350 x 150 ( w x h )

cable

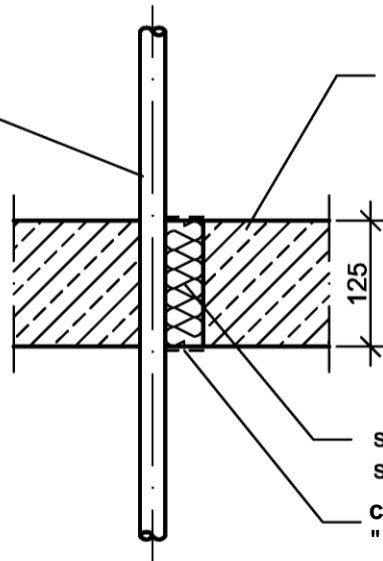

rigid floor acc. EN 1366-3;  
concrete,  $\rho = 2200 \pm 500 \text{ kg/m}^3$ ;  
EI 90 (EN 13501-2)

stuffing with mineral wool  
stuffing density 175 - 225 kg/m<sup>3</sup>  
coating with  
"PYROSAFE ASX",  
thickness 3 mm

cable	Designation	Insulation/sheath material	Standard
A1	NYJ-J 5x1,5 RE	PVC/PVC	HD 603.3G
A2	H 07 RN-F 5G1,5	EPR/PO	HD 22.4
A3	N2XH-J 5x1,5 RE	XLPE/EVA	HD 604,5G
B	NYJ-J x 95 RM	PVC/PVC	HD 603.3G

(cable in accordance with EN 1366 - 3 : 2009, Table A1)

PYROCOAT ASX

Use as a part of a cable penetration seal with the fire resistance class EI 60 (wall installation) respectively EI 90 (floor construction)

Annex 3