

Approval body for construction products
and types of construction

Bautechnisches Prüfamt

An institution established by the Federal and
Laender Governments



European Technical Assessment

ETA-05/0081
of 23 September 2019

English translation prepared by DIBt - Original version in German language

General Part

Technical Assessment Body issuing the
European Technical Assessment:

Deutsches Institut für Bautechnik

Trade name of the construction product

Bucher-Stair

Product family
to which the construction product belongs

Prefabricated stair with steps made of solid wood and a
load-bearing handrail made of solid wood or steel for use
as an indoor stair in buildings

Manufacturer

Treppenmeister GmbH
Emminger Straße 38
71131 Jettingen

Manufacturing plant

Treppenmeister, Plant 1 to Plant 85

This European Technical Assessment
contains

18 pages including 3 annexes which form an integral part
of this assessment

This European Technical Assessment is
issued in accordance with Regulation (EU)
No 305/2011, on the basis of

EAD 340006-00-0506

This version replaces

ETA-05/0081 issued on 16 January 2017

The European Technical Assessment is issued by the Technical Assessment Body in its official language. Translations of this European Technical Assessment in other languages shall fully correspond to the original issued document and shall be identified as such.

Communication of this European Technical Assessment, including transmission by electronic means, shall be in full. However, partial reproduction may only be made with the written consent of the issuing Technical Assessment Body. Any partial reproduction shall be identified as such.

This European Technical Assessment may be withdrawn by the issuing Technical Assessment Body, in particular pursuant to information by the Commission in accordance with Article 25(3) of Regulation (EU) No 305/2011.

Specific Part

1 Technical description of the product

The Bucher stair is a prefabricated stair, which consists of steps, railing (consisting of handrail, posts and balusters), fasteners, load-bearing bolts, wall ties and, where required, an intermediate landing.

On the wall-free side the steps are connected with each other by a load-bearing bolt and via balusters with the load-bearing handrail. On the wall side each step is equipped with a wall tie which is anchored in the staircase wall. Alternatively, the staircase wall may also be replaced by a wall string, a cut string or as on the wall-free side by a load-bearing handrail.

The steps are made of solid wood, the handrail, posts, distance sleeves and balusters are made of steel or solid wood and the fasteners, load-bearing bolts and wall ties are made of steel. The intermediate landing consists of a substructure with a plate made of solid wood.

The product description is given in Annex A. The material values, dimensions and tolerances of the components of the stair not indicated in the annexes shall correspond to the values laid down in the technical documentation¹.

2 Specification of the intended use in accordance with the applicable European Assessment Document

The performances given in Section 3 are only valid if the stair is used in compliance with the specifications and conditions given in Annex B.

The verification and assessment methods on which this European Technical Assessment is based lead to the assumption of a working life of the stair of at least 50 years. The indications given on the working life cannot be interpreted as a guarantee given by the producer, but are to be regarded only as a means for choosing the right products in relation to the expected economically reasonable working life of the works.

¹ The technical documentation comprises all information of the manufacturer necessary for the production, installation and maintenance of the stair; these are in particular the structural analysis, design drawings and the manufacturer's installation instructions. The part to be treated confidentially is deposited with Deutsches Institut für Bautechnik and, as far as this is relevant to the tasks of the approved bodies involved in the procedure of attestation of the AVCP-System, shall be handed over to the approved body.

3 Performance of the product and references to the methods used for its assessment

3.1 Mechanical resistance and stability (BWR 1)

Essential characteristic	Performance
Load-bearing capacity of stair	See Annex C2
Load-bearing capacity of fixings	See technical documentation of this European Technical Assessment
Load/displacement behaviour	See Annex C2
Vibration behaviour	First natural frequency: $f_1 \geq 5$ Hz (inclusive a single mass of 100 kg) Deflection under a single load $F = 1$ kN: $w \leq 5$ mm
Prevention of progressive collapse	Failure of individual components of the stair does not lead to a progressive collapse of the complete stair
Residual load-bearing capacity	Local material failure does not lead to an abrupt total loss of load-bearing capacity of the stair.
Long-term behaviour	Load-bearing capacity are ensured under an appropriate use and maintenance over the indicated working life
Resistance to earthquakes	No performance assessed
Durability against physical, chemical and biological agents	Adequate durability for the intended use under an appropriate use and maintenance

3.2 Safety in case of fire (BWR 2)

Essential characteristic	Performance
Reaction to fire	See Annex A7
Fire resistance	No performance assessed

3.3 Hygiene, health and the environment (BWR 3)

Essential characteristic	Performance
Release of formaldehyde	Wood adhesive does not contain formaldehyde
Release of pentachlorophenol	No pentachlorophenol treated materials are used
Radioactive emission	Not relevant

3.4 Safety in use (BWR 4)

Essential characteristic	Performance
Geometry	See Annex C1
Slipperiness	No performance assessed
Equipment of the stair for a safe use	Barrier and handrail are components of the stair (see Annexes A2 to A4 and C1) If vertical balusters, arranged between step and handrail, used as fill-in elements, a climb ability for infants will not be supported Tactility and visibility: No performance assessed
Safe breakage of components	No brittle failure of individual stair components made of wood or steel ESG-H: type C according to EN 12600:2002-11 VSG: type B according to EN 12600:2002-11
Impact resistance	Verified for filling elements made of glass up to a pendulum fall height of twin tyres (weight 50 kg) of 350 mm. Pendulum tests: test assembly according to EN 12600:2002-11 test performance according to TRAV ²

4 Assessment and verification of constancy of performance (AVCP) system applied, with reference to its legal base

In accordance with the European Assessment Document EAD No. 340006-00-0506 the applicable European legal act is: 1999/89/EC

The System to be applied is: 2+

In addition, with regard to reaction to fire for products covered by the European Assessment Document EAD No. 340006-00-0506 the applicable European legal act is: 2001/596/EC

The System to be applied is: 4

5 Technical details necessary for the implementation of the AVCP system, as provided for in the applicable European Assessment Document

Technical details necessary for the implementation of the AVCP system are laid down in the control plan deposited at Deutsches Institut für Bautechnik.

Issued in Berlin on 23 September 2019 by Deutsches Institut für Bautechnik

BD Dipl.-Ing. Andreas Kummerow
Head of Department

beglaubigt:
Stiller

² TRAV: Technical rules for glazings used as barrier against falling down, Version January 2003
(Technische Regeln für die Verwendung von absturzsichernden Verglasungen, Fassung Januar 2003)

English translation prepared by DIBt

Types of plan

Walking line exemplified,
position may be chosen freely
within the walking zone, walking
zone is 20 % of the clear width
of the stair in the middle of the
stair

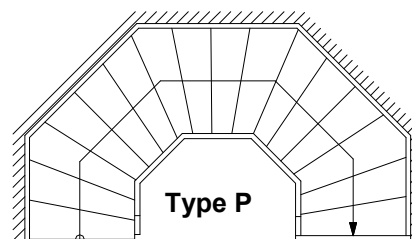
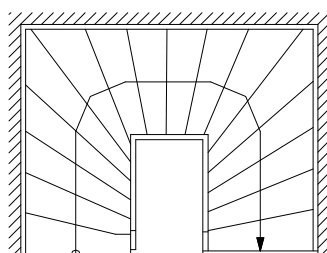
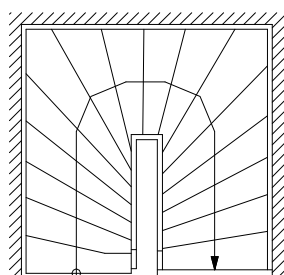
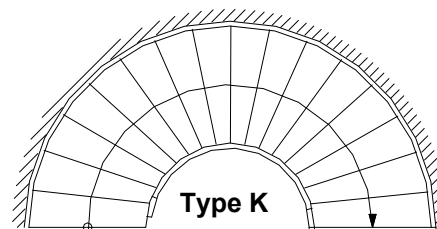
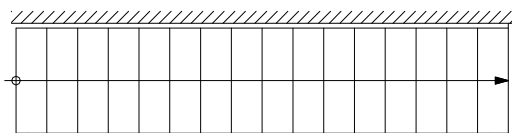
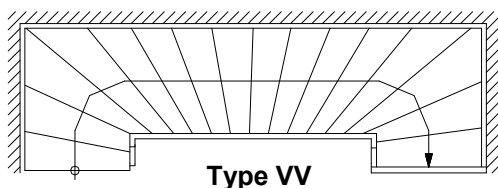
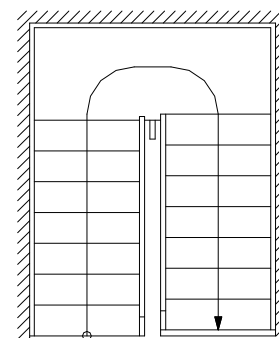
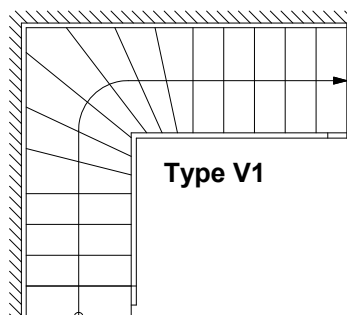
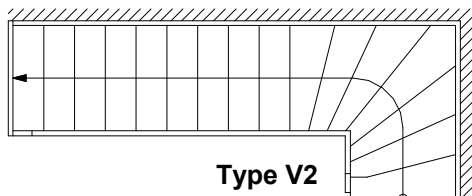
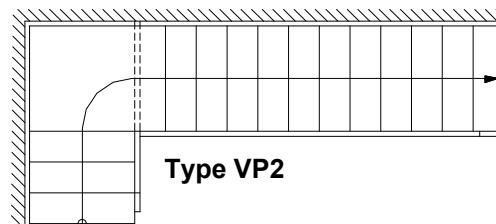
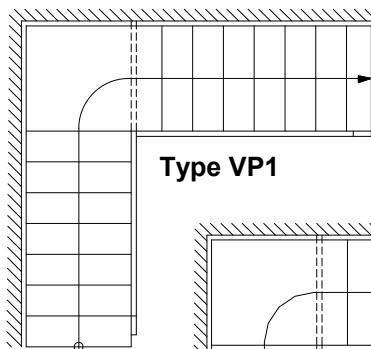
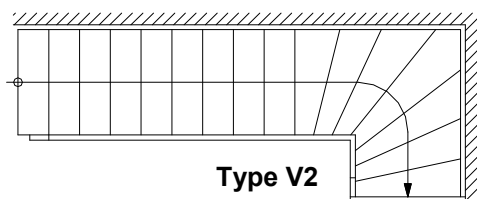

Electronic copy of the ETA by DIBt: ETA-05/0081

Bucher Stair	
Product	Annex A1

Types of construction

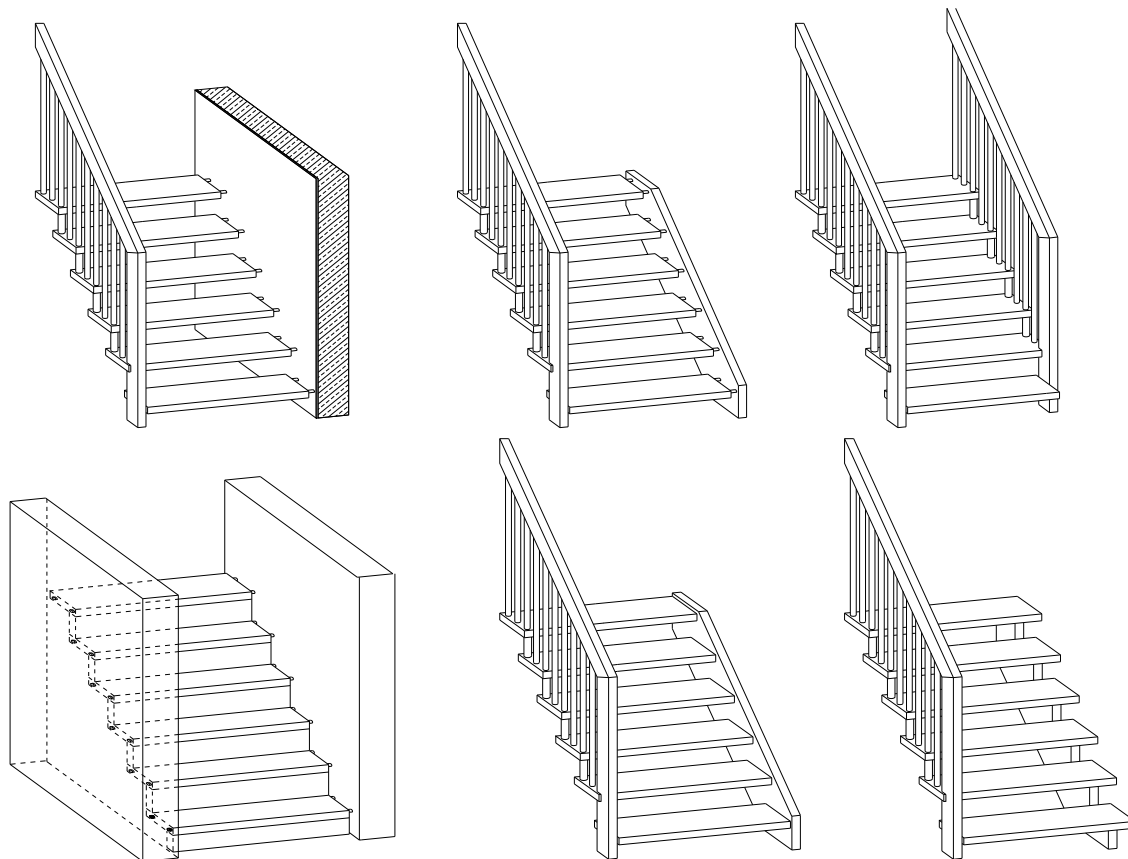

Support of the strings and cut strings on the wall side according to technical documentation

Wall ties

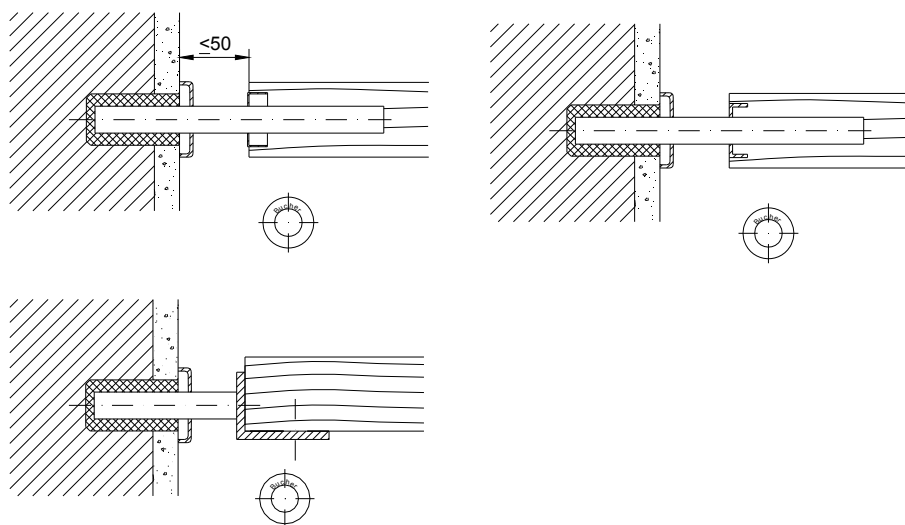

- Wall tie:**
- bearing sleeve (permanently elastic)
 - round steel bar \varnothing 16 mm
 - ferrule or U-section
 - plastic cover rosette
 - angle (for steps between two walls)

Further details according to the technical documentation

Bucher Stair

Product and intended use (Types of construction), Wall ties

Annex A2

Handrail corner joint

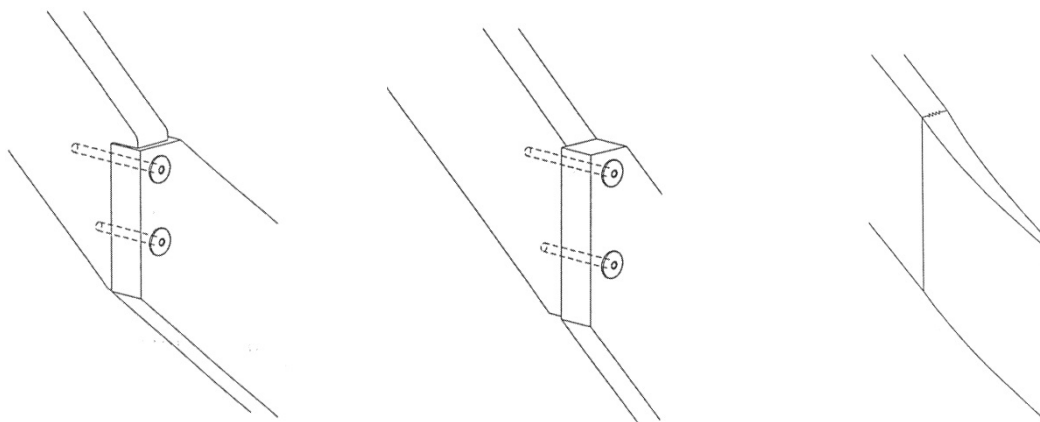

Post - handrail joint

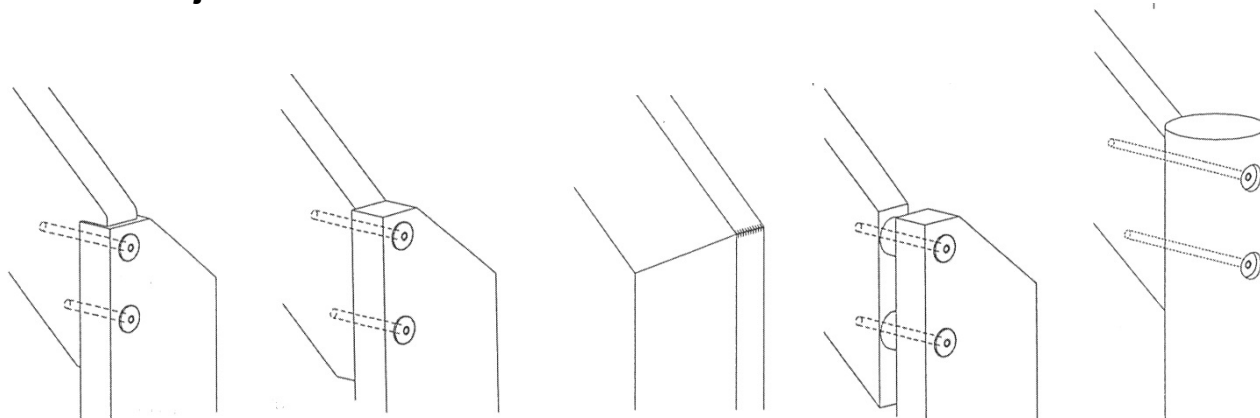

Step - post joint at bottom step

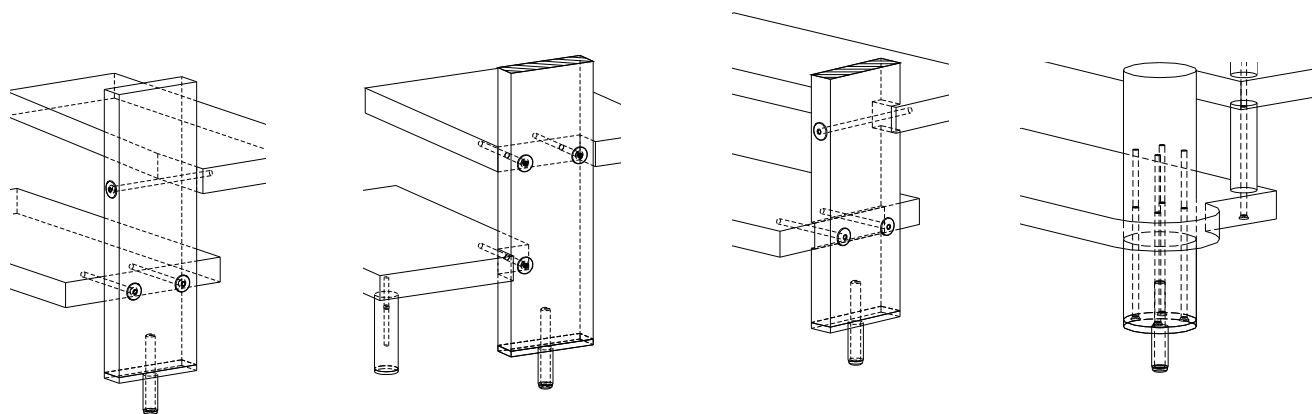

Further details according to the technical documentation

Bucher Stair

Handrail corner joint, Post-handrail joint,
Step-post joint

Annex A3

Step-baluster-handrail joint

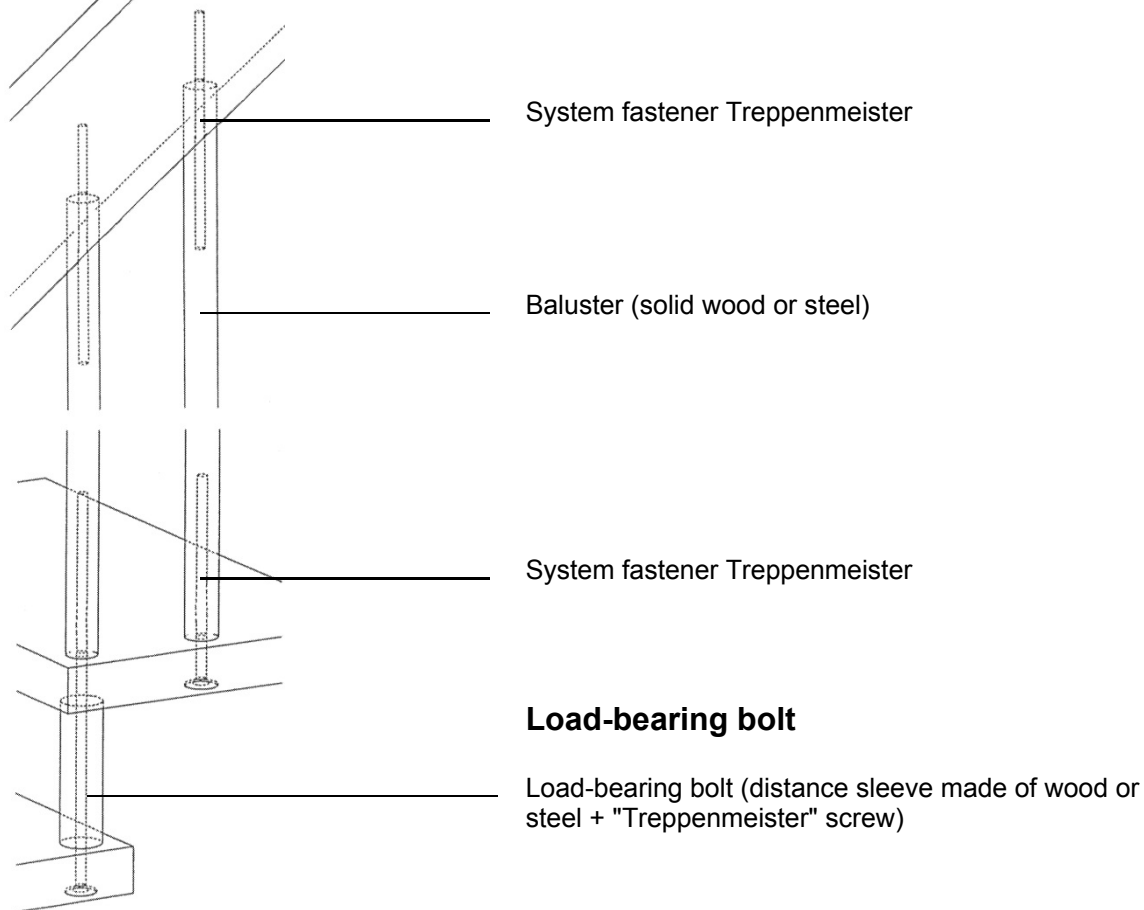

Barrier

Standard barrier

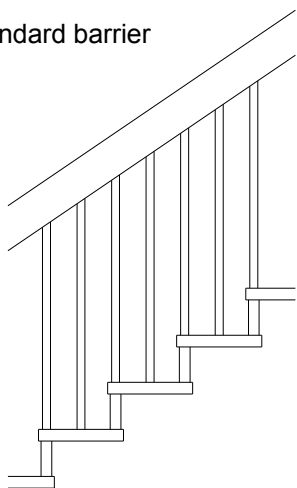

Glass barrier

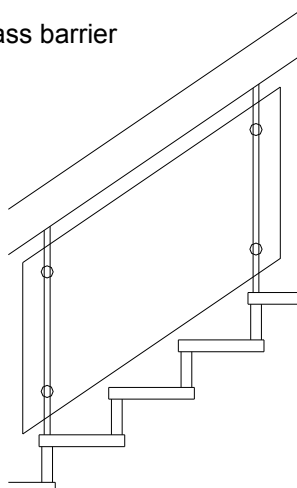

Railing barrier

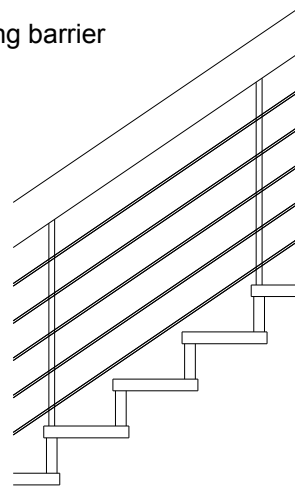

Further details according to the technical documentation

Bucher Stair

Step-baluster-handrail joint,
Load-bearing bolt, Barrier

Annex A4

**Load-bearing
bolt**

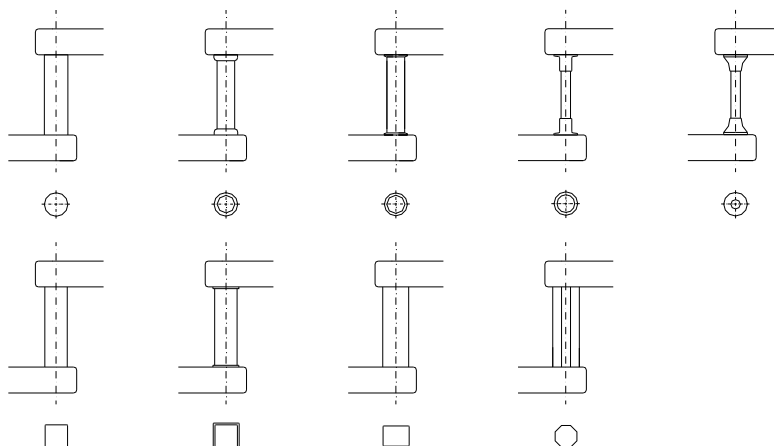

Step - cut string - joint

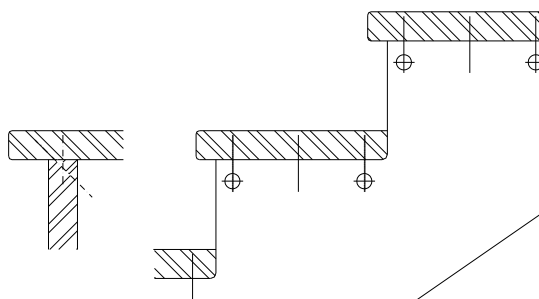

Step - string - joint

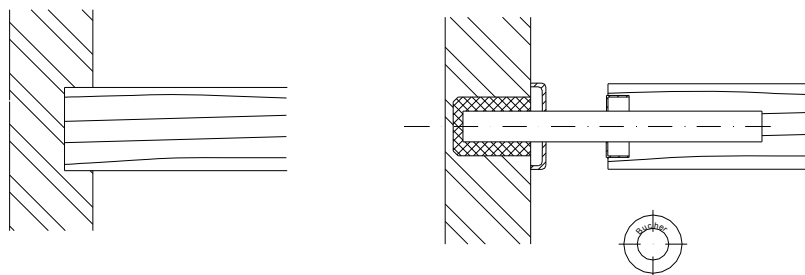

**Post joint
at the top**

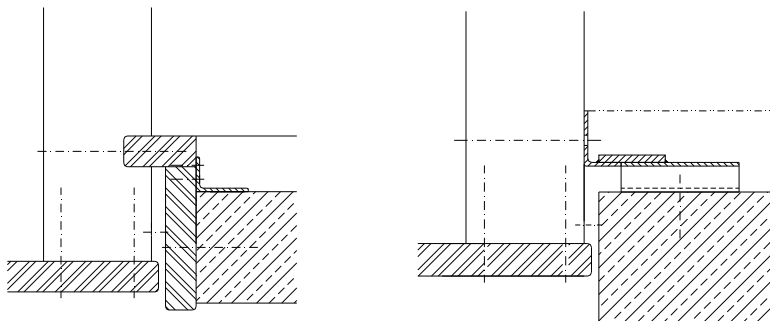

Further details according to the technical documentation

Bucher Stair

Load-bearing bolt, step - string - joints,
post joint at the top

Annex A5

Version with handrail made of steel
(for type of plan G with 15 rises and type V1 ,V2, H and VV with 17 rises)

Step - post joint at bottom step

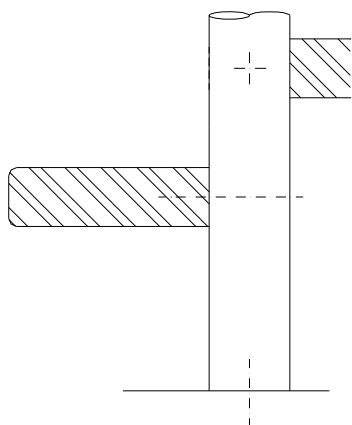

Post joint at the top

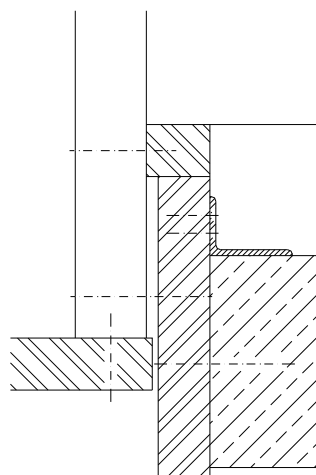

Step-baluster-handrail joint

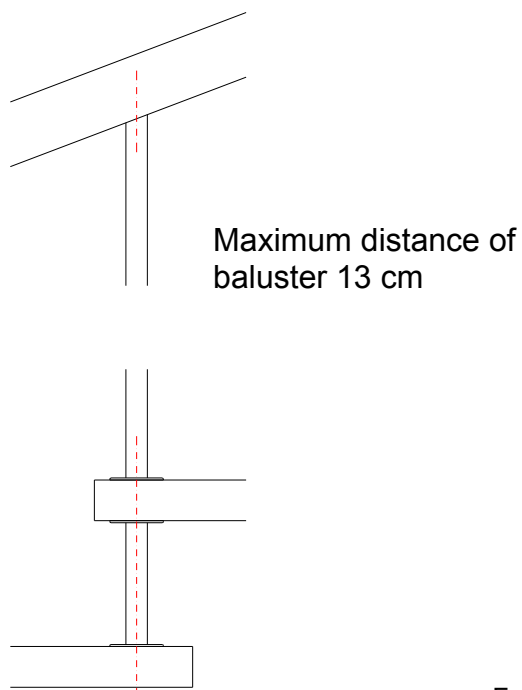

Handrail-corner-joint

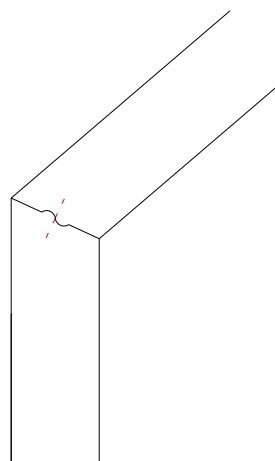

Further details according to technical documentation

Bucher Stair

Version with handrail made of steel

Annex A6

Table 1: Minimum dimensions of components of stair and reaction to fire

Component of stair		Material ¹⁾	Dimension		Value	Reaction to fire
Step		Solid wood ²⁾	Thickness	[mm]	44	D-s2, d0
Upper flange of the railing (handrail)		Solid wood ²⁾	Height / width	[mm]	- ³⁾	D-s2, d0
Handrail and post made of steel		Steel pipe ⁹⁾	Ø x thickness	[mm]	60.3 x 3.6	A1
Post		Solid wood ²⁾	Height / width	[mm]	as handrail	D-s2, d0
					90 / 90	
Baluster	Standard	Solid wood ²⁾	Diameter	[mm]	30 (26) ⁴⁾	D-s2, d0
		Steel pipe	Ø x thickness	[mm]	16 x 1.5	A1
	Glass or railing	Steel pipe	Ø x thickness	[mm]	21.3 x 2.0	A1
Filling elements		Glass ESG-H	Thickness	[mm]	8	A1
		Glass VSG ⁶⁾	Thickness	[mm]	2 x 4 mm ⁶⁾	no performance assessed
Load-bearing bolt / system fastener		Steel	Diameter	[mm]	10	A1
Distance sleeve (load-bearing bolt)		Solid wood ²⁾	Diameter	[mm]	40 (30) ⁵⁾	D-s2, d0
		Steel	Diameter	[mm]	16 ⁵⁾	A1
Wall ties		Round steel	Diameter	[mm]	16	A1
			Embedment depth wall	[mm]	55	
			Embedment depth step	[mm]	80	
Bearing sleeve (wall tie)		Plastic	Diameter	[mm]	30	Not relevant
Wall string		Solid wood ²⁾	Height / width	[mm]	44 x 240...310 ⁷⁾	D-s2, d0
Cut string			Height / width	[mm]	44 x 150...210 ⁸⁾	

1) Characteristic values of material according to technical documentation

2) Only wood of following species:

Group 1: Amazakoué, Bangkirai, Bongossi, Beech, Oak, Ash, Iroko/Kambala, Merbau, Wengé, Zebrano

Group 1*: Amazakoué, Bangkirai, Bongossi, Beech, Oak, Ash, Merbau, Wengé,

Group 2: Maple, Afzelia/Doussié, Acacia/Robinia, Birch, Bubinga, Cherry tree, Nut tree, Elm, Sapelli, Teak, Dibetou, Hevea

Group 2*: Maple, Afzelia/Doussié, Acacia/Robinia, Birch, Bubinga, Cherry tree, Nut tree, Teak

Group 2**: Maple, Acacia/Robinia, Birch, Teak

Group 3: Pine, Larch

3) According to Table 2 and technical documentation

4) Values in brackets only outside of the embedment range of the system fastener

5) Only with a washer $\varnothing \geq 40$

6) VSG consists of 2 x 4 mm TVG and 1.52 mm PVB-foil

7) Dimensions according to ETA-10/0215

8) Dimensions according to ETA-13/0197

9) Only in combination with wood of group 1 possible

Bucher Stair

Minimum dimensions of components of the stair
and reaction to fire

Annex A7

**Table 2: Minimum dimensions of handrail cross sections made of solid wood
(Types of plan P, H, VP1, VP2 and K)**

Type of plan	Rises	Gr. of wood species	Dimensions of the handrail width x height in mm ¹⁾	
			screwed	finger jointed
P	≤ 17	1	44 x 150...160	44 x 150...160
	≤ 15	1	44 x 120...130	44 x 120...130
		2	44 x 130...140	44 x 130...140
H	≤ 20	1*	44 x 160...170	44 x 160...170
		2**	44 x 180...190	44 x 180...190
	≤ 17	1	44 x 120...140	44 x 120...140
		2	44 x 130...140	44 x 130...140
		3	44 x 170...200	44 x 140...160
	≤ 15	1	44 x 120	44 x 120
		2	44 x 120	44 x 120
		3	44 x 120	44 x 120
	VP1	≤ 20	1*	-
2**			-	44 x 210
≤ 17		1	-	50 x 170...180
		1*	-	44 x 180
		2	-	50 x 190...200
≤ 15		2*	-	44 x 190
		1	-	44 x 140...160
		2	-	50 x 160...180
		2*	-	44 x 170
VP2	≤ 20	1*	-	44 x 200
		2*	-	44 x 210
	≤ 17	1	-	50 x 170...180
		1*	-	44 x 170...180
		2*	-	44 x 180...190
	≤ 15	1	-	44 x 150...160
		2	-	50 x 160...170
2*	-	44 x 160...170		
K	≤ 17	1	44 x 150...160	44 x 150...160
	≤ 15	1	44 x 120...130	44 x 120...130
		2	44 x 130...140	44 x 130...140
		3	44 x 130...140	44 x 130...140

¹⁾ From...to data depend on the clear width of the stair (850...1000 mm) and the type of barrier, Intermediate values according to technical documentation

Bucher Stair

Minimum dimensions of handrail cross sections made of solid wood
(Types of plan P, H, VP1, VP2 and K)

Annex A8

**Table 3: Minimum dimensions of handrail cross sections made of solid wood
(Types of plan G, HP, V2 and VV)**

Type of plan	Rises	Gr. of wood species	Dimensions of the handrail width x height in mm ¹⁾		
			screwed	finger jointed	
G, HP	≤ 20	1*	44 x 200	44 x 200	
		2**	-	44 x 210	
	≤ 17	1	50 x 160...180	50 x 160...180	
		1*	44 x 170...180	44 x 170...180	
		2	50 x 190...200	50 x 190...200	
		2*	-	44 x 180...190	
		3	-	53 x 180...200	
	≤ 15	1	50 x 140...160 (44 x 120...140) ²⁾	50 x 140...160 (44 x 120...140) ²⁾	
		1*	44 x 140...160	44 x 140...160	
		2	50 x 160...180 (44 x 130...150) ²⁾	50 x 160...180 (44 x 130...150) ²⁾	
		2*	-	44 x 150...170	
		3	50 x 180...200 (44 x 130...150) ²⁾	44 x 160...180 (44 x 130...150) ²⁾	
	V2	≤ 20	1*	-	44 x 200
			2**	-	44 x 210
		≤ 17	1	50 x 170...180	50 x 170...180
1*			44 x 180	44 x 180	
2			-	58 x 180...220 ³⁾	
2**			-	44 x 190	
≤ 15		1	44 x 130...140	44 x 130...140	
		2	44 x 150...160	44 x 150...160	
		3	44 x 150...160	44 x 150...160	
VV	≤ 20	1*	44 x 170...180	44 x 170...180	
		2**	-	44 x 180...190	
	≤ 17	1	44 x 130...150	44 x 130...150	
		2	44 x 140...160	44 x 140...160	
		3	44 x 140...160	44 x 140...160	
	≤ 15	1	44 x 120...140	44 x 120...140	
		2	44 x 130...150	44 x 130...160	
		3	44 x 130...150	44 x 130...160	

1) From...to data depend on the clear width of the stair (850...1000 mm) and type of barrier,

Intermediate values according to technical documentation

2) Values in bracket for stairs with 10 rises maximum

3) Maximum clear width of the stair: 950 mm

Bucher Stair

Minimum dimensions of handrail cross sections made of solid wood
(Types of plan G, HP, V2 and VV)

Annex A9

Specification of intended use (Part 1)

Intended use:

- European Technical Assessment applies for a construction system.
- For the specific case of use the corresponding type of stair is manufactured within the context of the values defined in this European Technical Assessment.
- Values of this ETA applies to all types of stairs, the real dimensions follow in accordance with the relevant case of use.

Stair subject to:

- Static and quasi static loads

Use conditions:

- Indoor stair
- Air temperatures between +5 °C and +30 °C
- Relative air humidity between 30% and 70%

Design:

- Design of the stair according to the annexes and the technical documentation of this European Technical Assessment.
- Fastening of the stair to the construction works according to the annexes and the technical documentation of this Technical European Assessment.
- Verification of the transmission of loads to the construction works by the civil engineer responsible for the construction works.
- Load bearing capacity at ultimate limit state:

$$q_k \cdot \gamma_Q \leq q_{RK} / \gamma_M$$

$$Q_k \cdot \gamma_Q \leq Q_{RK} / \gamma_M$$

$$h_k \cdot \gamma_Q \cdot \psi_0 \leq h_{RK} / \gamma_M$$

with

q_{RK}, Q_{RK}, h_{RK} : characteristic values of resistance; see Table 5

γ_M : recommended material partial safety factor; see Table 5

q_k, Q_k, h_k : characteristic values of imposed loads according to EN 1991-1-1:2002 + AC:2009

$\gamma_Q = 1.5$: recommended partial safety factor, in absence of other national regulations

$\psi_0 = 0.7$: recommended combination factor, in absence of other national regulations

- Maximum characteristic values of imposed loads under consideration of the partial factors mentioned above; see Table 7

Bucher Stair

Specification of intended use (Part 1)

Annex B1

Specification of intended use (Part 2)

Installation:

- Installation by personal appropriately trained and authorized by the manufacturer by means of the technical documentation of this European Technical Assessment
- Installation only in the way as specified in the technical documentation of this European Technical Assessment
- Installation of timber components when moisture content of timber components is $8 \pm 2 \%$
- Sufficient support of the stair when assembling
- Installation of stair components without imposed deformations
- Installation of stair components without significant defects and cracks
- Replacing of stair components, which begin tearing when assembling
- Bolted connection are protected such that they will not be loosened by vibrations

Indication of the manufacturer:

- Ensure that all persons involved will be appropriately informed about the specific conditions according to sections 1 and 2 (including the annexes to which reference is being made as well as the not confidential parts of the technical documentation deposited to this European Technical Assessment)
- Packaging of timber components such that the wood moisture is $8 \pm 2 \%$ during transport and storage
- Instructions for use should provide information as to use, maintenance and repair of the stair. Including the information of avoidance of moisture penetration of the timber components and of retightens the bolting of the load-bearing bolts and connections according to Annexes A3 to A5 after the first heating season and the information on the relationship between moisture content of timber components, air temperature and relative air humidity

Electronic copy of the ETA by DIBt: ETA-05/0081

Bucher Stair	Annex B2
Specification of intended use (Part 2)	

Table 4: Geometry

Designation		Dimension		
		Minimum	Maximum	
Going	Step on walking line ¹⁾	[mm]	210	370 ²⁾
	Tapered step	[mm]	60 ^{2) 3)}	600 ^{2) 4)}
Rise of the stairs ¹⁾		[mm]	140 ²⁾	210
Pitch of the walking line ¹⁾		[°]	21	45
Overlap of steps	Wall side	[mm]	30	- ⁵⁾
	Wall-free side	[mm]	60	- ⁵⁾
Number of rises			3	20
Openings	Between barrier and other parts of the stair	[mm]	0	0
	Between stairs and wall	[mm]	- ⁵⁾	50
	Between consecutive steps	[mm]	- ⁵⁾	166
	Between balusters	[mm]	40	840 ⁶⁾
Clear width of stairs		[mm]	500	1000
Minimum headroom		[mm]	- ⁵⁾	
Length of the flight		[mm]	- ⁵⁾	4940
Thickness of steps		[mm]	44	- ⁵⁾
Height of the barrier / handrail		[mm]	900	1000
Handrail made of solid wood	Width	[mm]	44	58
	Height	[mm]	120	210
Handrail made of steel pipe	outer diameter	[mm]	60,3	- ⁵⁾
Clear distance of handrail to adjacent components		[mm]	50	

- 1) Values are constant within one flight
- 2) Tolerance between nominal value and actual value = ± 5 mm
- 3) Wall-free side of tapered step
- 4) Wall side of tapered step
- 5) Not relevant
- 6) With filling elements according to Annex A4

- 1 **Going**
- 2 **Rise**
- 3 **Overlap**
- 4 **Opening between consecutive steps**
- 5 **Length of the flight**
- 6 **Thickness of steps**
- 7 **Height of the railing / barrier**
- 8 **Opening between balusters**

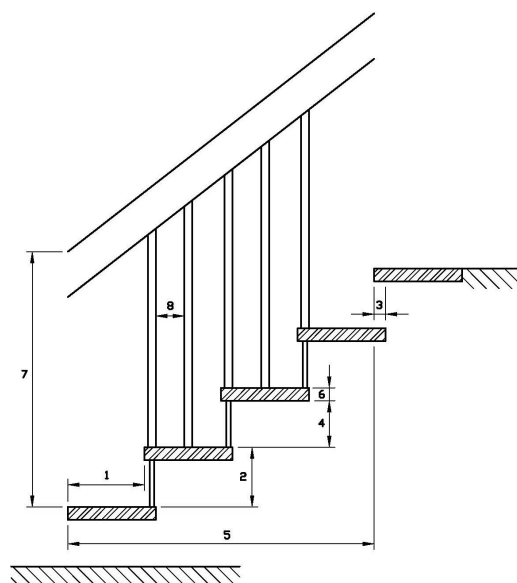

Bucher Stair

Geometry of the stair

Annex C1

Table 5: Load-bearing capacity – Characteristic values of resistance

Type of loading	Characteristic values of resistance			γ_M ¹⁾
vertical variable uniformly distributed load	q_{Rk}	[kN/m ²]	5.0	1.1
vertical variable single load	Q_{Rk}	[kN]	3.3	
horizontal variable uniformly distributed load on barrier	h_{Rk}	[kN/m]	0.6	

¹⁾ Recommended partial safety factor, in absence of other national regulations

Table 6: Deflections under loading

Deflection of the flight under uniformly distributed load			
uniformly distributed load	q_k	[kN/m ²]	3.0
length of the median line of the flight	L	[mm]	4940
deflection under load F_S related to the median line of the flight	w	[-]	$\leq L/200$
Deflection of the step under single point load			
single load	Q_k	[kN]	2.0
clear width of the stair	L	[mm]	1000
deflection under load F_S related to the clear width of the stair	w	[-]	$\leq L/200$

Table 7: Imposed loads

Type of loading	Imposed loads		
vertical variable uniformly distributed load	q	[kN/m ²]	3.0
vertical variable single load	Q	[kN]	2.0
horizontal variable uniformly distributed load on barrier	h	[kN/m]	0.5

Bucher Stair

Load-bearing capacity – Characteristic values of resistance
Deflections under loading,
Imposed loads

Annex C2