

Approval body for construction products
and types of construction

Bautechnisches Prüfamt

An institution established by the Federal and
Laender Governments



European Technical Assessment

ETA-09/0252
of 31 October 2023

English translation prepared by DIBt - Original version in German language

General Part

Technical Assessment Body issuing the
European Technical Assessment:

Deutsches Institut für Bautechnik

Trade name of the construction product

Krieger HPL-small string stair

Product family
to which the construction product belongs

Prefabricated stair kits

Manufacturer

Treppenbau
"System Krieger" GmbH
Gewerbegebiet Wolf
56841 Traben-Trarbach
DEUTSCHLAND

Manufacturing plant

Krieger Treppen GmbH Werk 1-99

This European Technical Assessment
contains

14 pages including 3 annexes which form an integral part
of this assessment

This European Technical Assessment is
issued in accordance with Regulation (EU)
No 305/2011, on the basis of

340006-00-0506

This version replaces

ETA-09/0252 issued on 12 September 2014

The European Technical Assessment is issued by the Technical Assessment Body in its official language. Translations of this European Technical Assessment in other languages shall fully correspond to the original issued document and shall be identified as such.

Communication of this European Technical Assessment, including transmission by electronic means, shall be in full. However, partial reproduction may only be made with the written consent of the issuing Technical Assessment Body. Any partial reproduction shall be identified as such.

This European Technical Assessment may be withdrawn by the issuing Technical Assessment Body, in particular pursuant to information by the Commission in accordance with Article 25(3) of Regulation (EU) No 305/2011.

Specific Part

1 Technical description of the product

The Krieger small string stair is a prefabricated stair system, which consists of steps, strings and system fasteners. The steps are connected with the strings by four system fasteners. The steps and are made of solid wood (only hardwood), the strings are made of high-pressure laminates (HPL) and the system fasteners are made of steel.

The product description is given in Annex A. The material values, dimensions and tolerances of the components of the stair not indicated in the annexes shall correspond to the values laid down in the technical documentation¹.

2 Specification of the intended use in accordance with the applicable European Assessment Document

The performances given in Section 3 are only valid if the stair is used in compliance with the specifications and conditions given in Annex B.

The verification and assessment methods on which this European Technical Assessment is based lead to the assumption of a working life of the stair of at least 50 years. The indications given on the working life cannot be interpreted as a guarantee given by the producer, but are to be regarded only as a means for choosing the right products in relation to the expected economically reasonable working life of the works.

¹ The technical documentation comprises all information of the manufacturer necessary for the production, installation and maintenance of the stair; these are in particular the structural analysis, design drawings and the manufacturer's installation instructions. The part to be treated confidentially is deposited with Deutsches Institut für Bautechnik and, as far as this is relevant to the tasks of the approved bodies involved in the procedure of attestation of the AVCP-System, shall be handed over to the approved body.

3 Performance of the product and references to the methods used for its assessment

3.1 Mechanical resistance and stability (BWR 1)

Essential characteristic	Performance
Load-bearing capacity <ul style="list-style-type: none"> - Load-bearing capacity of the stair - Load-bearing capacity of components of the stair - Load-bearing capacity of fixings 	Q_{RK} , q_{RK} and h_{RK} : See Annex C2 H_{RK} : No performance assessed M_{RK} , V_{RK} , N_{RK} , E , G , f_{mk} und f_{vk} : See technical documentation of this European Technical Assessment See technical documentation of this European Technical Assessment
Load-Displacement behaviour	w_q and w_Q : See Annex C2
Vibration behaviour	First natural frequency: $f_1 \geq 5$ Hz Deflection under a single load $F = 1$ kN: $w_{Q1} \leq 5$ mm
Prevention of progressive collapse	Failure of individual components of the stair does not lead to a progressive collapse of the complete stair
Residual load-bearing capacity	Local material failure does not lead to an abrupt total loss of load-bearing capacity of the stair
Long-term behaviour	Load-bearing capacity are ensured under an appropriate use and maintenance over the indicated working life
Resistance to earthquakes	No performance assessed
Durability against physical, chemical, biological agents	Adequate durability for the intended use under an appropriate use and maintenance

3.2 Safety in case of fire (BWR 2)

Essential characteristic	Performance
Reaction to fire	See Annex A5
Fire resistance	No performance assessed

3.3 Hygiene, health and the environment (BWR 3)

Essential characteristic	Performance
Release of formaldehyde	Class E1
Release of pentachlorophenol	No pentachlorophenol treated materials are used
Radioactive emission	No performance assessed

3.4 Safety in use (BWR 4)

Essential characteristic	Performance
Geometry	See Annex C1
Slipperiness	No performance assessed
Equipment of the stair for a safe use	No performance assessed
Safe breakage of components	No brittle failure of individual components made of solid wood and wood-based products No dangerous by components made of HPL when accidentally broken
Impact resistance	No performance assessed

4 Assessment and verification of constancy of performance (AVCP) system applied, with reference to its legal base

In accordance with the European Assessment Document EAD No. 340006-00-0506 the applicable European legal act is: 1999/89/EC

The System to be applied is: 2+

In addition, with regard to reaction to fire for products covered by the European Assessment Document EAD No. 340006-00-0506 the applicable European legal act is: 2001/596/EC

The System to be applied is: 4

5 Technical details necessary for the implementation of the AVCP system, as provided for in the applicable European Assessment Document

Technical details necessary for the implementation of the AVCP system are laid down in the control plan deposited at Deutsches Institut für Bautechnik.

Issued in Berlin on 31 October 2023 by Deutsches Institut für Bautechnik

Dipl.-Ing. Beatrix Wittstock
Head of Section

beglaubigt:
Stiller

Types of plans with 16 rises

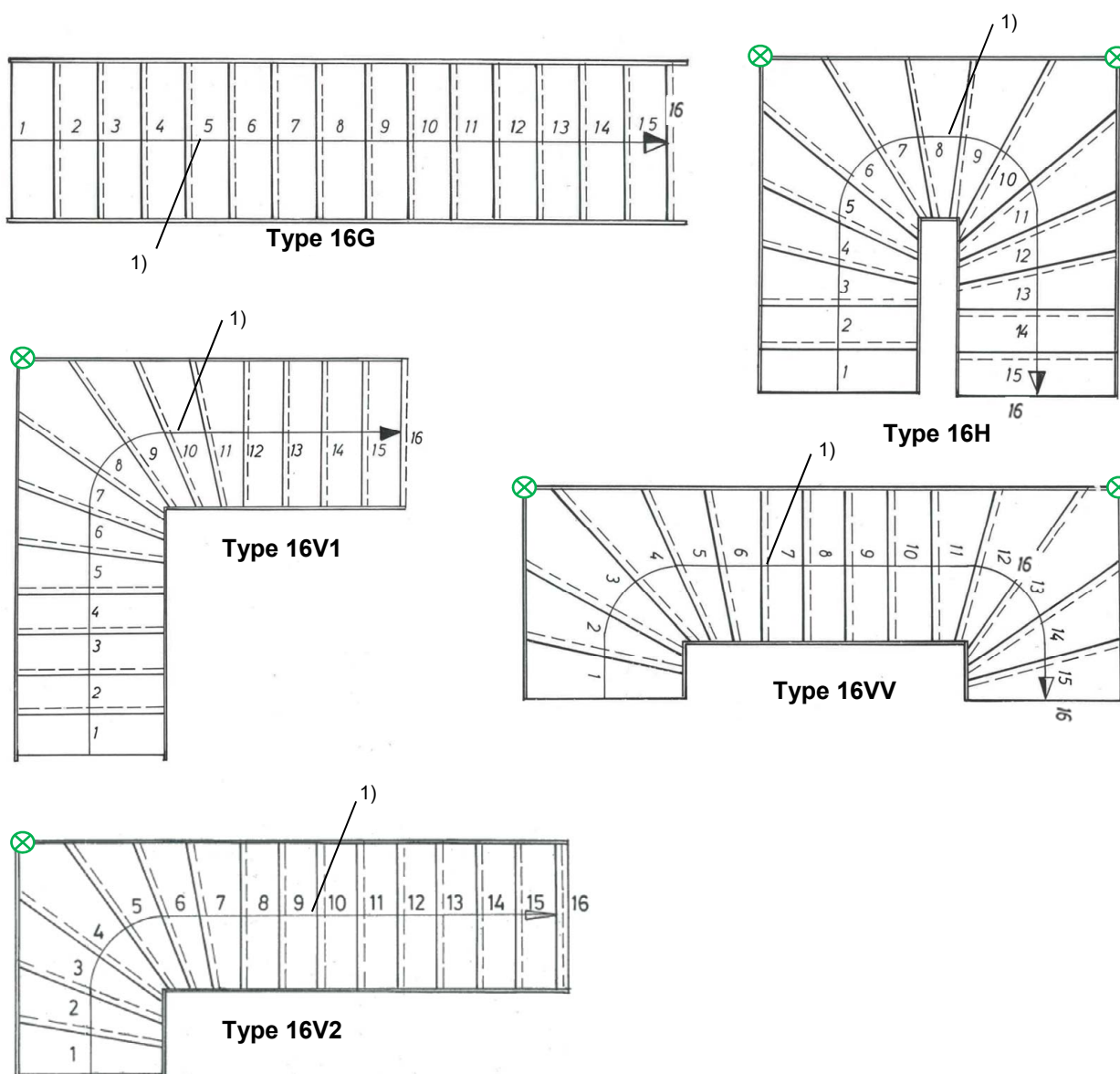

⊗ Additional support for vertical loads at maximum number of steps
(Supports for less steps according to technical documentation)

Horizontal fixings to the wall according to technical documentation

1) Walking line is exemplified, position may be chosen freely within the walking zone, walking zone is 20 % of the clear width of the stair in the middle of the stair

Krieger HPL-small string stair

Product
(Types of plans with 16 rises)

Annex A1

Types of plans with 18 rises

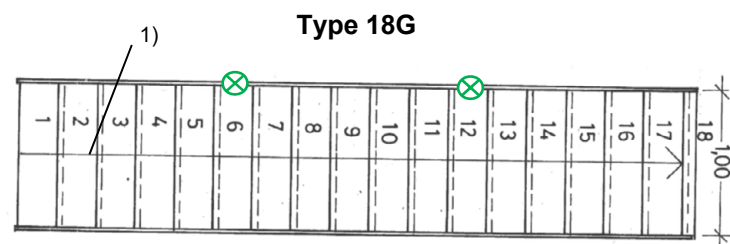

Type 18G

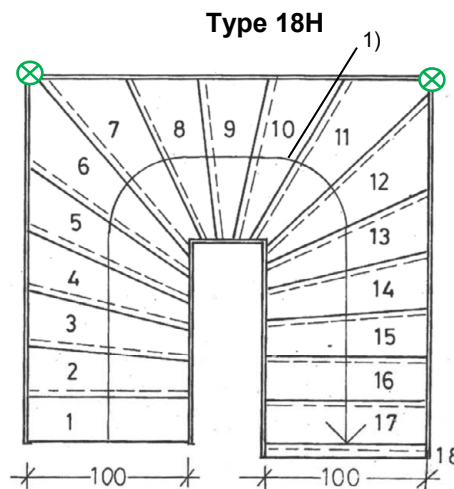

Type 18H

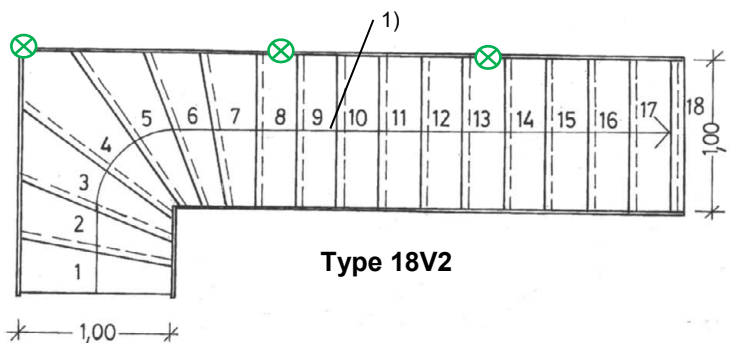

Type 18V2

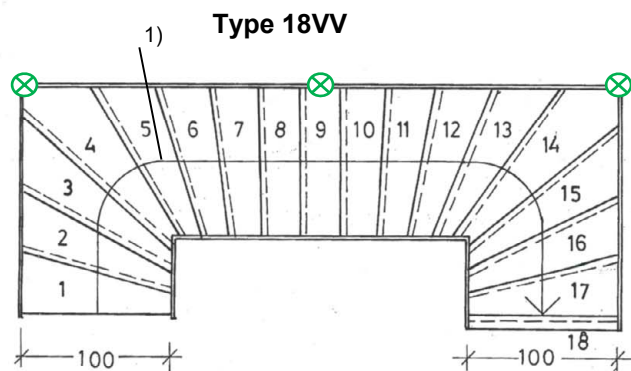

Type 18VV

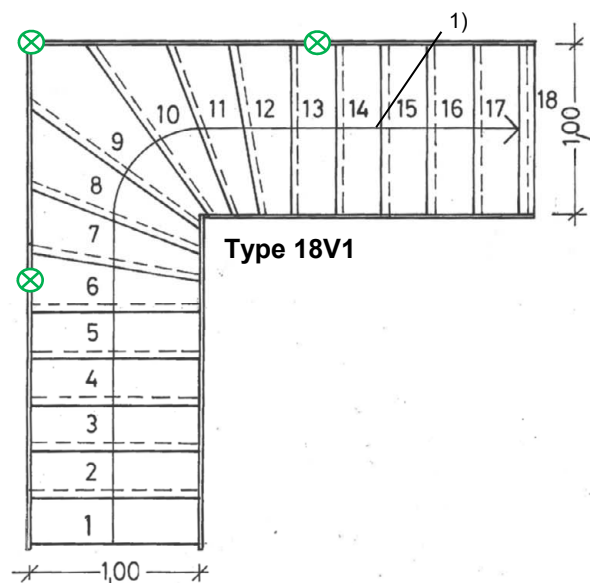

Type 18V1

Construction

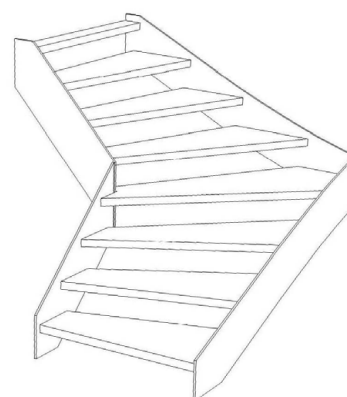

- ⊗ Additional support for vertical loads at maximum number of steps (supports for less steps according to technical documentation)

Horizontal fixings to the wall according to technical documentation

- 1) Walking line is exemplified, position may be chosen freely within the walking zone, walking zone is 20 % of the clear width of the stair in the middle of the stair

Krieger HPL-small string stair

Product
(Types of plans with 18 rises, Constructions)

Annex A2

Step-string-joint

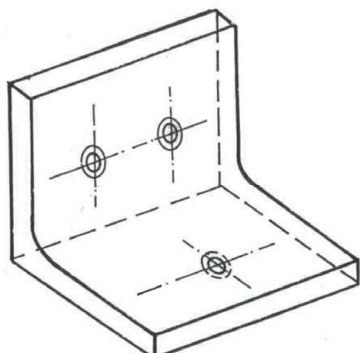

Corner of strings

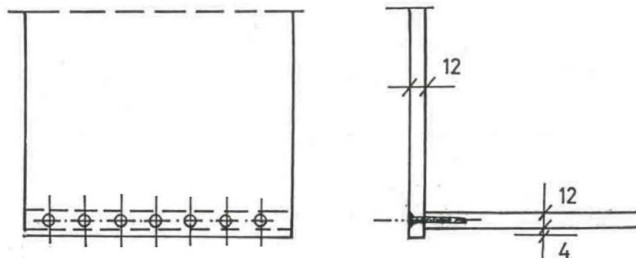

String-corner joint wall-free side

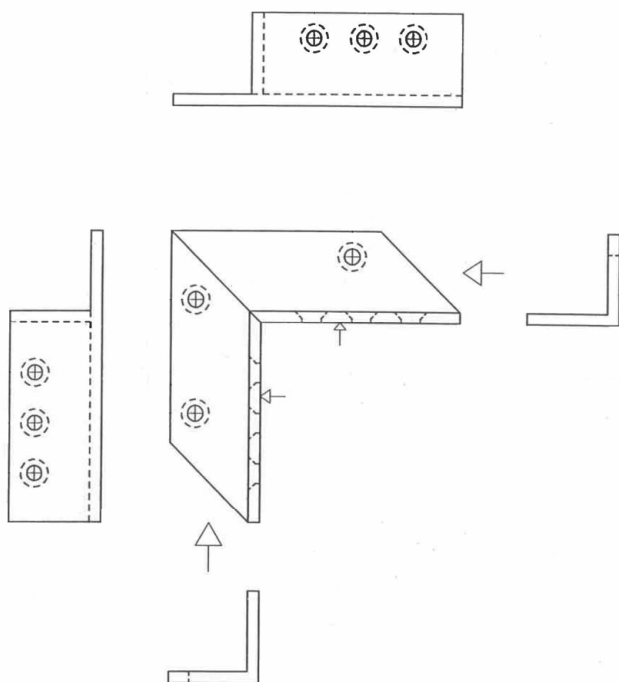

String-corner joint wall side

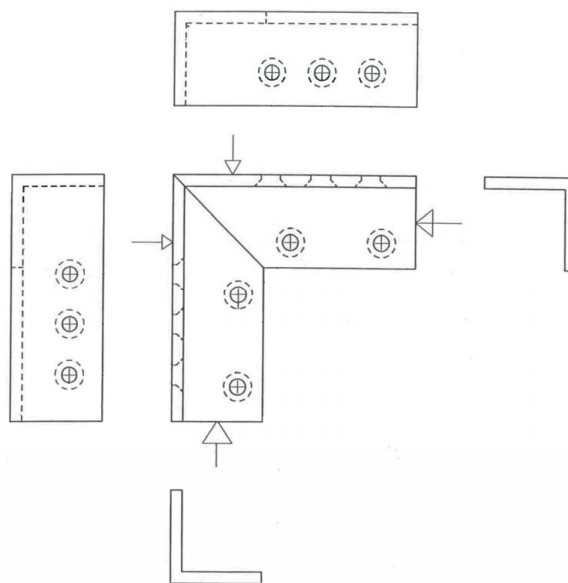

more details according to the technical documentation

Krieger HPL-small string stair

Step-string joint, corner of strings,
string-corner joint

Annex A3

Wall fixing

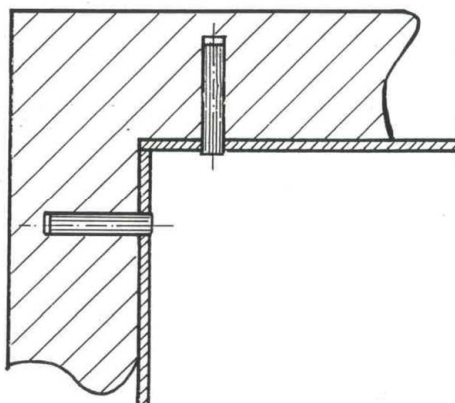

Joint at bottom

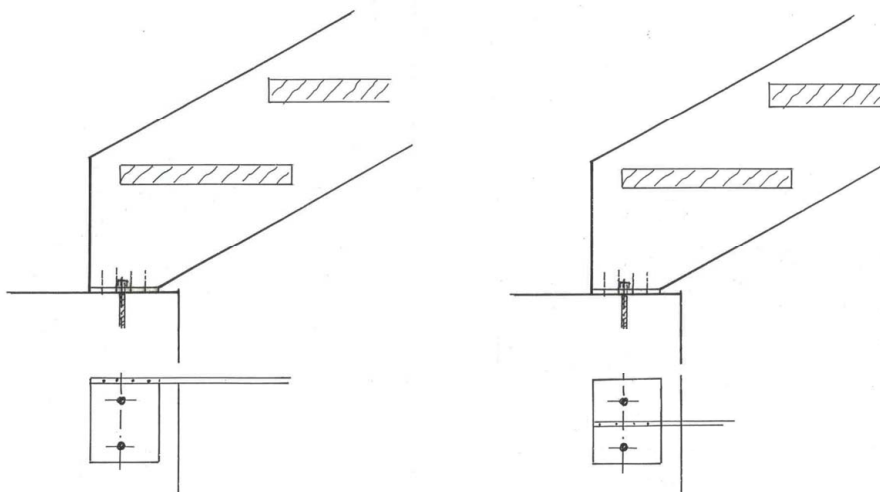

Joint at the top

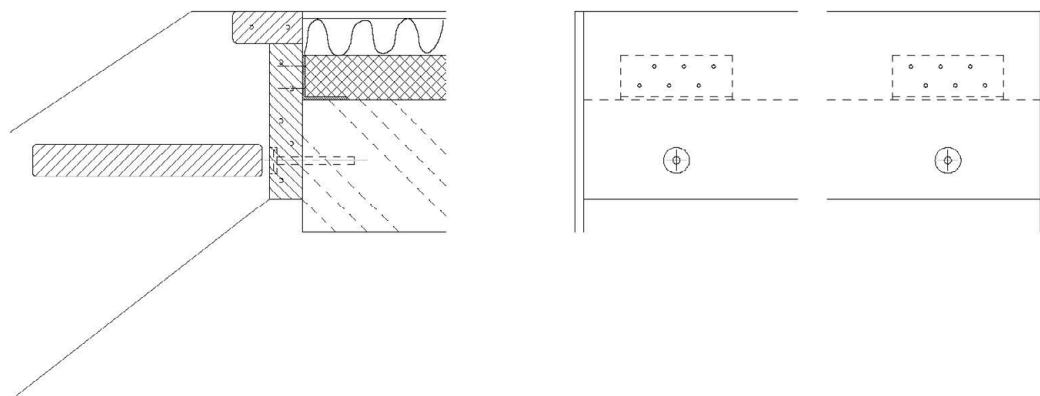

more details according to the technical documentation

Krieger HPL-small string stair

Wall fixing, joint at bottom, joint at the top

Annex A4

Table 1: Minimum dimensions of relevant stair components and reaction to fire

Component	Material ¹⁾	Dimension		Value	Reaction to fire
Steps	Solid wood ²⁾	Thickness	[mm]	44	D-s2, d0
Strings Type 16	High-pressure laminate HPL	Thickness / Height	[mm]	12 / 300	D-s2, d0
Strings Type 18V1				12 / 320	
Strings Type 18 other types of plans				12 / 300	
Wall tie	Steel	Diameter	[mm]	25	A1
Angle joint, System fastener	Steel	- ³⁾			A1

¹⁾ characteristic values of material according to technical documentation

²⁾ only hardwood of the following species: beech, oak, maple, acacia, ash, nut tree, birch, cheery tree, elm, doussie, merbau,

³⁾ characteristic values according to technical documentation

Krieger HPL-small string stair

Minimum dimensions of relevant stair components and reaction to fire

Annex A5

Specification of intended use (Part 1)

Intended use:

- European Technical Assessment applies for a construction system.
- For the specific case of use the corresponding type of stair is manufactured within the context of the values defined in this European Technical Assessment.
- Values of this ETA apply to all types of stairs; the real dimensions follow in accordance with the relevant case of use.

Stair subject to:

- Static and quasi-static loads

Use conditions:

- Indoor stair
- Air temperatures between +5 °C and +30 °C
- Relative air humidity between 30% and 70%
- To the individual requirements handrail and barrier can be attached to the stair optionally. Conditions for possible handrail/barrier:
 - Dead load $\leq 0,15$ kN/m
 - Height $\leq 0,90$ m
 - Distance of baluster $\leq 0,85$ m

Design:

- Design of the stair according to the annexes and the technical documentation of this European Technical Assessment.
- Fastening of the stair to the construction works according to the annexes and the technical documentation of this Technical European Assessment.
- Verification of the transmission of loads to the construction works by the civil engineer responsible for the construction works.
- Load bearing capacity at ultimate limit state:

$$q_k \cdot \gamma_Q \leq q_{Rk} / \gamma_M$$

$$Q_k \cdot \gamma_Q \leq Q_{Rk} / \gamma_M$$

$$h_k \cdot \gamma_Q \cdot \psi_0 \leq h_{Rk} / \gamma_M$$

with

q_{Rk} , Q_{Rk} , h_{Rk} : characteristic values of resistance; see Table 3

γ_M : recommended material partial safety factor; see Table 3

q_k , Q_k , h_k : characteristic values of imposed loads according to EN 1991-1-1:2002 + AC:2009

$\gamma_Q = 1,5$: recommended partial safety factor, in absence of other national regulations

$\psi_0 = 0,7$: recommended combination factor, in absence of other national regulations

- Maximum characteristic values of imposed loads under consideration of the partial factors mentioned above; see Table 5

Krieger HPL-small string stair

Specification of intended use (Part 1)

Annex B1

Specification of intended use (Part 2)

Installation:

- Installation by personal appropriately trained and authorized by the manufacturer by means of the technical documentation of this European Technical Assessment
- Installation only in the way as specified in the technical documentation of this European Technical Assessment
- Installation of timber components when moisture content of timber components is $8 \pm 2 \%$
- Sufficient support of the stair when assembling
- Installation of stair components without imposed deformations
- Installation of stair components without significant defects and cracks
- Replacing of stair components, which begin tearing when assembling
- Bolted connections are protected such that they will not be loosened by vibrations

Indication of the manufacturer:

- Ensure that all persons involved will be appropriately informed about the specific conditions according to sections 1 and 2 (including the annexes to which reference is being made as well as the not confidential parts of the technical documentation deposited to this European Technical Assessment)
- Packaging of timber components such that the wood moisture is $8 \pm 2 \%$ during transport and storage
- Instructions for use should provide information as to use, maintenance and repair of the stair including the information of avoidance of moisture penetration of the timber components and the information on the relationship between moisture content of timber components, air temperature and relative air humidity

Krieger HPL-small string stair	Annex B2
Specification of intended use (Part 2)	

Table 2: Geometry

Designation			Dimension	
			Minimum	Maximum
Going	Step on walking line ¹⁾	[mm]	210	370 ²⁾
	Tapered step	[mm]	100 ^{2) 3)}	550 ^{2) 4)}
Rise of the stairs ¹⁾		[mm]	140 ²⁾	210
Pitch of the walking line ¹⁾		[°]	21	45
Overlap of the steps		[mm]	30	- ⁵⁾
Number of rises		[-]	3	18
Openings	Between stairs and wall	[mm]	- ⁵⁾	60 ⁶⁾
	Between consecutive steps	[mm]	- ⁵⁾	166
Clear width of stairs		[mm]	500	1000
Minimum headroom		[mm]	- ⁵⁾	
Length of the flight		[mm]	- ⁵⁾	4590
Thickness of steps		[mm]	44	- ⁵⁾

- 1) values are constant within one flight
- 2) tolerance between nominal value and actual value = ± 5 mm
- 3) inside of tapered step
- 4) outside of tapered step
- 5) not relevant
- 6) at the wall tie 5 mm

- 1 Going
- 2 Rise
- 3 Overlap
- 4 Opening between consecutive steps
- 5 Length of the flight
- 6 Thickness of steps

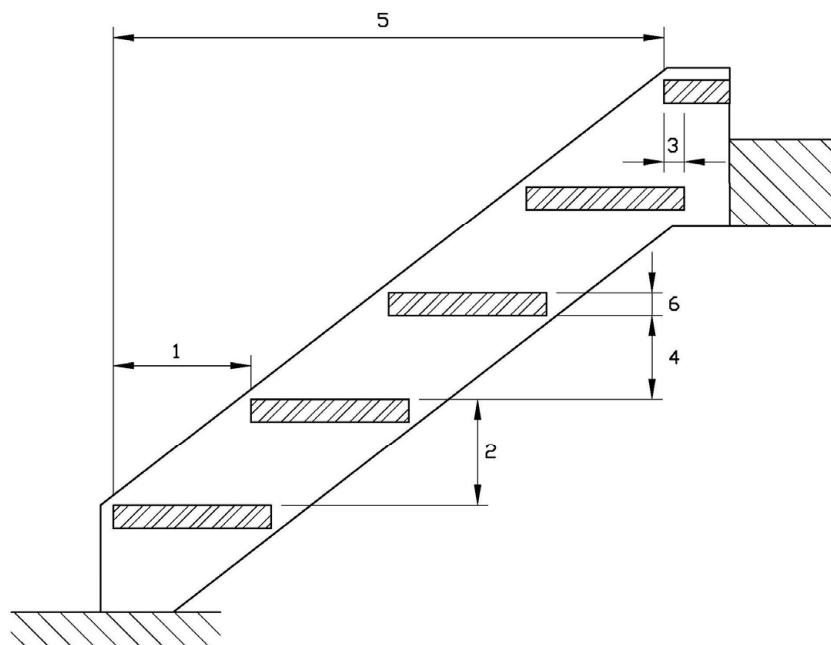

Krieger HPL-small string stair

Geometry of the stair

Annex C1

Table 3: Load-bearing capacity – Characteristic values of resistance

Type of loading	Characteristic values of resistance			γ_M
Vertical variable uniformly distributed load	q_{Rk}	[kN/m ²]	6,75	1,5 ¹⁾
Vertical variable single load	Q_{Rk}	[kN]	4,5	
Horizontal variable uniformly distributed load on barrier	h_{Rk}	[kN/m]	0,8	

¹⁾ Recommended partial safety factor, in absence of other national regulations

Table 4: Deflections under loading

Durchbiegung des Treppenlaufs unter gleichmäßig verteilte Last			
Uniformly distributed load	q_k	[kN/m ²]	3,0
Length of the median line of the flight Type 16	L	[mm]	4050
Length of the median line of the flight Type 18			4590
Deflection related to the median line of flight	w_q	[-]	≤ L/200
Deflection under single load			
Single load	Q_k	[kN]	2,0
Clear width of the stair	L	[mm]	1000
Deflection related to the clear width of stair	w_Q	[-]	≤ L/200

Table 5: Imposed loads

Type of loading	Imposed loads		
Vertical variable uniformly distributed load	q_k	[kN/m ²]	3,0
Vertical variable single load	Q_k	[kN]	2,0
Horizontal variable uniformly distributed load on barrier	h_k	[kN/m]	0,5

Krieger HPL-small string stair

Load-bearing capacity - Characteristic values of resistance,
Deflections under loading,
Imposed loads

Annex C2