

Approval body for construction products
and types of construction

Bautechnisches Prüfamt

An institution established by the Federal and
Laender Governments



European Technical Assessment

ETA-22/0434
of 24 January 2023

English translation prepared by DIBt - Original version in German language

General Part

Technical Assessment Body issuing the
European Technical Assessment:

Deutsches Institut für Bautechnik

Trade name of the construction product

KBS Sealant

Product family
to which the construction product belongs

product for use in penetration seals - fire protective
sealant

Manufacturer

Wolman Wood and Fire Protection GmbH
Dr.-Wolmann-Straße 31-33
76547 Sinzheim
DEUTSCHLAND

Manufacturing plant

Wolman Wood and Fire Protection GmbH
Werk Illertissen, Bau 20
Robert-Hansen-Straße 1
89257 Illertissen
DEUTSCHLAND

This European Technical Assessment
contains

9 pages including 5 annexes which form an integral part
of this assessment

This European Technical Assessment is
issued in accordance with Regulation (EU)
No 305/2011, on the basis of

EAD 350454-00-1104

The European Technical Assessment is issued by the Technical Assessment Body in its official language. Translations of this European Technical Assessment in other languages shall fully correspond to the original issued document and shall be identified as such.

Communication of this European Technical Assessment, including transmission by electronic means, shall be in full. However, partial reproduction may only be made with the written consent of the issuing Technical Assessment Body. Any partial reproduction shall be identified as such.

This European Technical Assessment may be withdrawn by the issuing Technical Assessment Body, in particular pursuant to information by the Commission in accordance with Article 25(3) of Regulation (EU) No 305/2011.

Specific Part

1 Technical description of the product

The construction product "KBS Sealant" is an ablative sealant.

The construction product is a water based, viscous, non-halogen ablative sealant (as delivered). The product essentially consists of the chemically/physically reactive substances and binder and forms hard layers after application.

The product "KBS Sealant" is a material used in fire applications to close gaps. It consumes energy or releases matter through chemical or physical processes when exposed to fire without significant expansion.

A detailed technical description and fire safety related performance criteria in relation to the construction product are given in Annex 1.

NOTE:

The characteristics listed are suitable both for identifying the construction product as well as for performing the manufacturer's factory production control.

2 Specification of the intended use in accordance with the applicable European Assessment Document

The construction product "KBS Sealant" is intended for use as a component with a fire protection effect in penetration seals that are subject to fire safety requirements. In the event of fire, its reactive effect helps prevent the passage of heat and the spread of fire.

Construction products for penetration seals are used to seal openings in fire-resistant floors and walls, which are penetrated by services. Their function is to preserve the walls' or floors' resistance to fire in the area of openings where services were fed through.

This ETA served to verify the resistance to fire of penetration seals consisting of the products listed in Annexes 1 and 2.

The performance data in Section 3 relates only to the penetration seals tested as part of this assessment (e.g. regarding the design and arrangement of the penetration seal components and the type and position of the services).

3 Performance of the product and references to the methods used for its assessment

3.1 Safety in case of fire (BWR 2)

Essential characteristic	Performance
Reaction to fire	Class E in accordance with EN 13501-1
Resistance to fire of mixed penetration seals ¹ / multiple penetration seals for pipes ¹ (including blank seal in accordance with EN 1366-3) containing the product, installed in flexible walls and rigid floors	max. EI 120 in accordance with EN 13501-2 (see Annexes 3 to 5)

¹ The fire resistance depends on the design and installation of the penetration seal, on the other components forming the penetration seal and on the penetrating services. Annexes 1 to 5 include details on the penetration seals for which the fire resistance indicated was demonstrated.

3.2 Hygiene, health and the environment (BWR 3)

Essential characteristic	Performance
Content and release of dangerous substances	No dangerous substances ²

3.3 General aspects

Testing the essential characteristics includes the verification of durability.

The construction product "KBS Sealant" may be used under end-use conditions in accordance with the provisions applying to use category Z₁ (indoor conditions with high humidity (including temporary condensation) but without temperatures below 0 °C) without significant changes in the characteristics relevant for fire protection to be expected.

4 Assessment and verification of constancy of performance (AVCP) system applied, with reference to its legal base

In accordance with EAD No. 350454-000-1104 the applicable European legal act is: 1999/454/EC.

The system to be applied is: system 1.

5 Technical details necessary for the implementation of the AVCP system, as provided for in the applicable EAD

Technical details necessary for the implementation of the AVCP system are laid down in the test plan (control plan) deposited with Deutsches Institut für Bautechnik.

Issued in Berlin on 24. January 2023 by Deutsches Institut für Bautechnik

Christina Pritzkow
Head of Section

beglaubigt:
Meske-Dallal

² In accordance with Regulation (EC) No 1272/2008 of the European Parliament and the European Council of 16 December 2008 (published in the Official Journal of the European Communities L 353 of 31 December 2008, p. 1)

Properties and performances criteria of the construction product "KBS Sealant"^{*}

Property/ Performance criteria	Parameter
Density	1440 ± 100 kg/m ³
LOI	≥ 95,0 % (sample thickness approx. 2,0 mm)
Reaction to fire	class E

The properties listed can be used both for the identification of the construction product and for the implementation of the factory production control of the manufacturer.

Implementation details for the factory production control are included in the inspection plan.

* It is an ablative sealant (viscous mass). The composition of the material is deposited at DIBt.

¹ Details on the test procedure are deposited at DIBt.

Performances of tested penetration seals, comprising the construction product "KBS Sealant"

No	Essential requirement	Test method	Construction of the sample	Performance acc. to EN 13501-2
1	Resistance to fire	EN 1366-3	200 mm thick mixed penetration seal with dimensions of 600 mm x 1000 mm (w x h) in a 100 mm thick flexible wall; design and layout of the penetration seal according to Annex 3 [*]	EI 120
2	Resistance to fire	EN 1366-3	120 mm thick blank penetration seal with dimensions of 1200 mm x 1200 mm in a 100 mm thick flexible wall	EI 120
3	Resistance to fire	EN 1366-3	200 mm thick mixed penetration seal with dimensions of 800 mm x 800 mm in a 150 mm thick aerated concrete floor; design and layout of the penetration seal according to Annex 4 [*]	EI 120 ^{**}
4	Resistance to fire	EN 1366-3	150 mm thick multiple penetration seal for pipes with dimensions of 800 mm x 800 mm in a 150 mm thick aerated concrete floor; design and layout of the penetration seal according to Annex 5 [*]	EI 120
5	Resistance to fire	EN 1366-3	150 mm thick blank penetration seal with dimensions of 1200 mm x 800 mm in a 150 mm thick aerated concrete floor (design analogue No 4 [*])	EI 120

* Illustrations without guarantee for completeness

The tested/illustrated penetration seals are examples only.

** without consideration of the cable with the designation "G2".

The use of the construction product "KBS Sealant" in penetration seals shall be in accordance with national requirements for planning, design and execution and in accordance with the installation instruction of the manufacturer.

KBS Sealant

Description of the construction products, properties and performances

Properties of the construction product "KBS Sealant" and performance of penetration seals comprising the construction product "KBS Sealant"

Annex 1

Description of the additional components in the area of the tested penetration seals

Framing of the opening in the flexible wall	Gypsum plasterboard acc. to EN 520, Type F thickness: 12,5 mm Reaction to fire class A according to EN 13501-1
Beading for wall installation	Promatect-H according to doP No. 0749-CPR-06/0206-2018/2, thickness 25 mm, width 100 mm
Beading for floor installation	Promatect-L according to doP No. 0749-CPR-07/0296-2018/1, thickness 50 mm, width 100 mm

Description of the additional components of the tested penetration seals

Designation / Manufacturer	Description
"KBS FR Caulking" Wolman Wood and Fire Protection GmbH 892578 Illertissen Germany	Intumescent putty , mass with high viscosity according to ETA-22/0435
"KBS Coating" Wolman Wood and Fire Protection GmbH 892578 Illertissen Germany	Ablative coating , liquid coating according to ETA-22/0436
"Hardrock 040" ("Hardrock II") Deutsche Rockwool Mineralwoll GmbH 45966 Gladbeck Germany	Mineral wool board according to DIN EN 13162 thickness: 60 mm nominal density: 150 kg/m ³ Reaction to fire class according to DIN EN 13501-1: class A1
"Pipe Seal SN" Wolman Wood and Fire Protection GmbH 892578 Illertissen Germany	Pipe collar with sheet steel housing and intumescent material according to ETA-16/0214
"Rohrschale 800" ("Lapinus Rohrschale") Deutsche Rockwool Mineralwoll GmbH 45966 Gladbeck Germany	Mineral wool pipe section according to DIN EN 14303 thickness: 30 mm nominal density: 100 kg/m ³ Reaction to fire class according to DIN EN 13501-1: class A2L-s1, d0

KBS Sealant

Description of the construction products, properties and performances
Properties of additional components of penetration seals comprising the construction
product "KBS Sealant"

Annex 2

Layout of the test specimen for wall application
Seal thickness: 200 mm

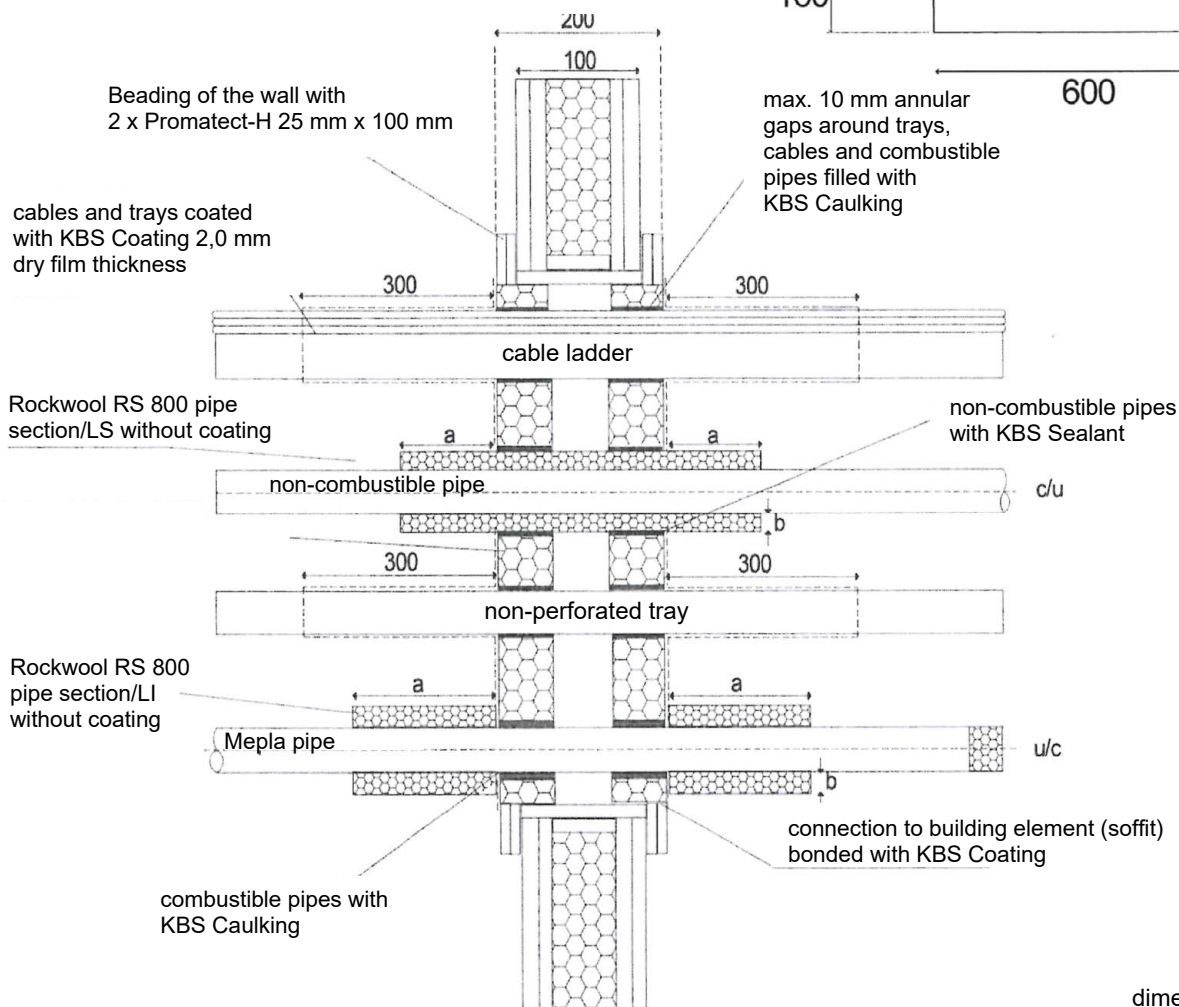
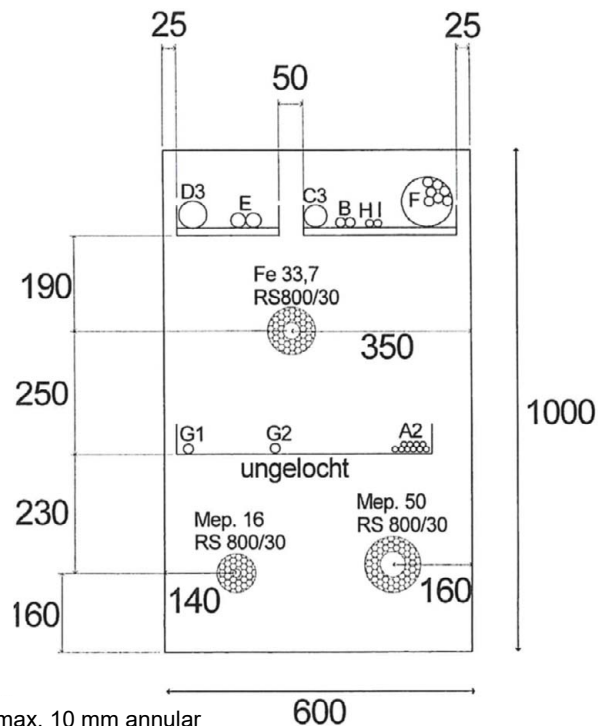

dimensions in mm

KBS Sealant

Use as a component of a mixed penetration seal of resistance to fire class **EI 120**
Layout of the test specimen in the flexible wall – seal thickness: 200 mm

Annex 3

Layout of the test specimen for floor application
Seal thickness: 200 mm

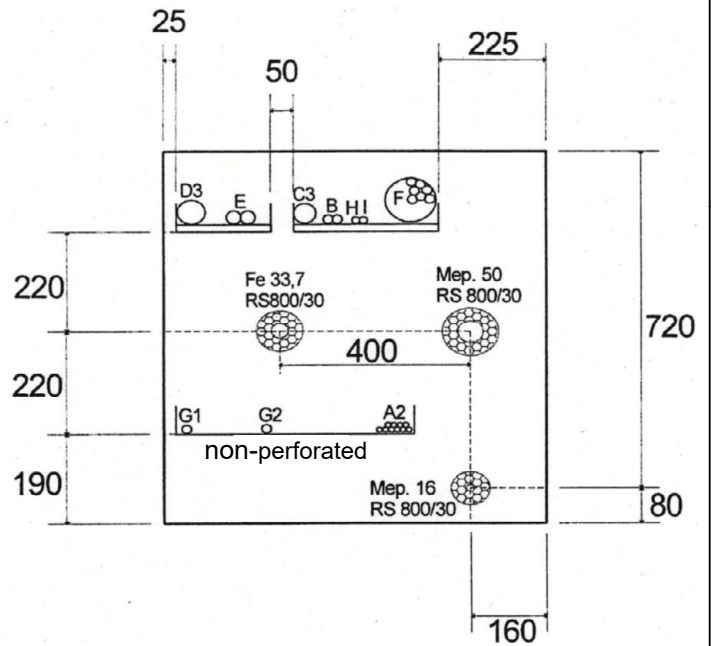

Rockwool RS 800 pipe section/LS without coating

Rockwool RS 800 pipe section/LI without coating

cables and trays coated with KBS Coating 2,0 mm dry film thickness

max. 10 mm annular gaps around trays, cables and combustible pipes filled with KBS Caulking

Rockwool Hardrock 040 (60 mm) one sided coated with KBS Coating 1,5 mm dry film thickness

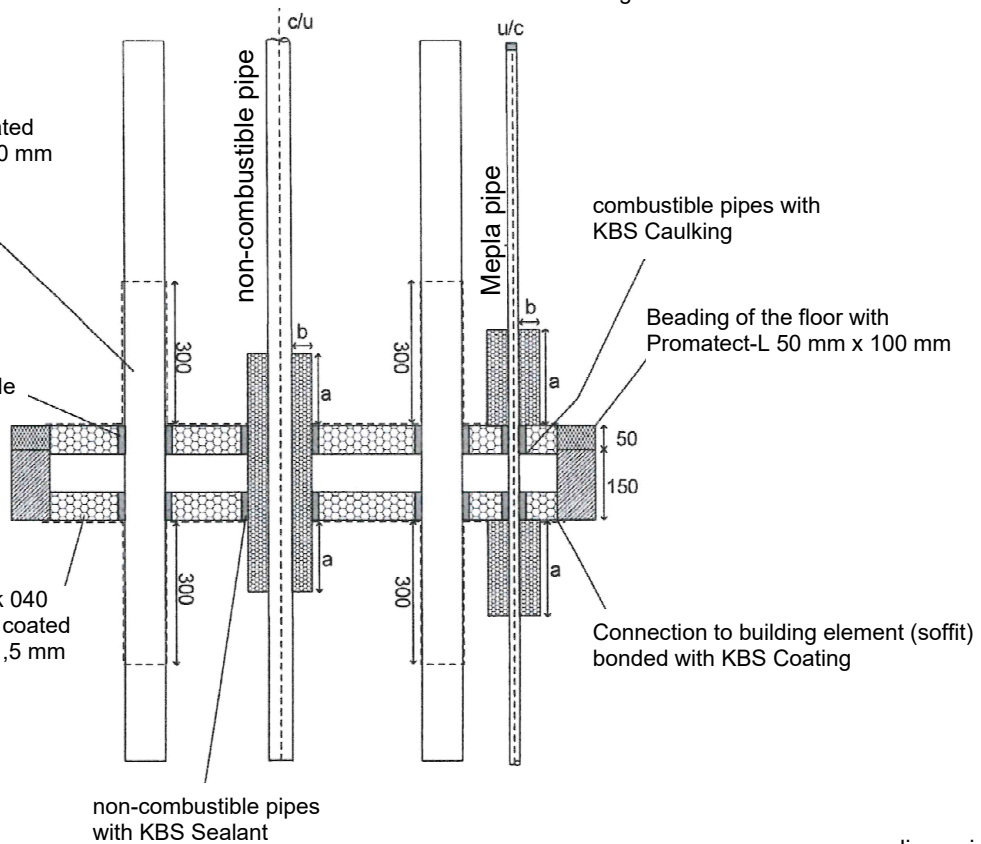

dimensions in mm

KBS Sealant

Use as a component of a mixed penetration seal of resistance to fire class **EI 120**
(optional non-shaded cables unconsidered)
Layout of the test specimen in the floor – seal thickness: 200 mm

Annex 4

Layout of the test specimen for floor application
Seal thickness: 150 mm

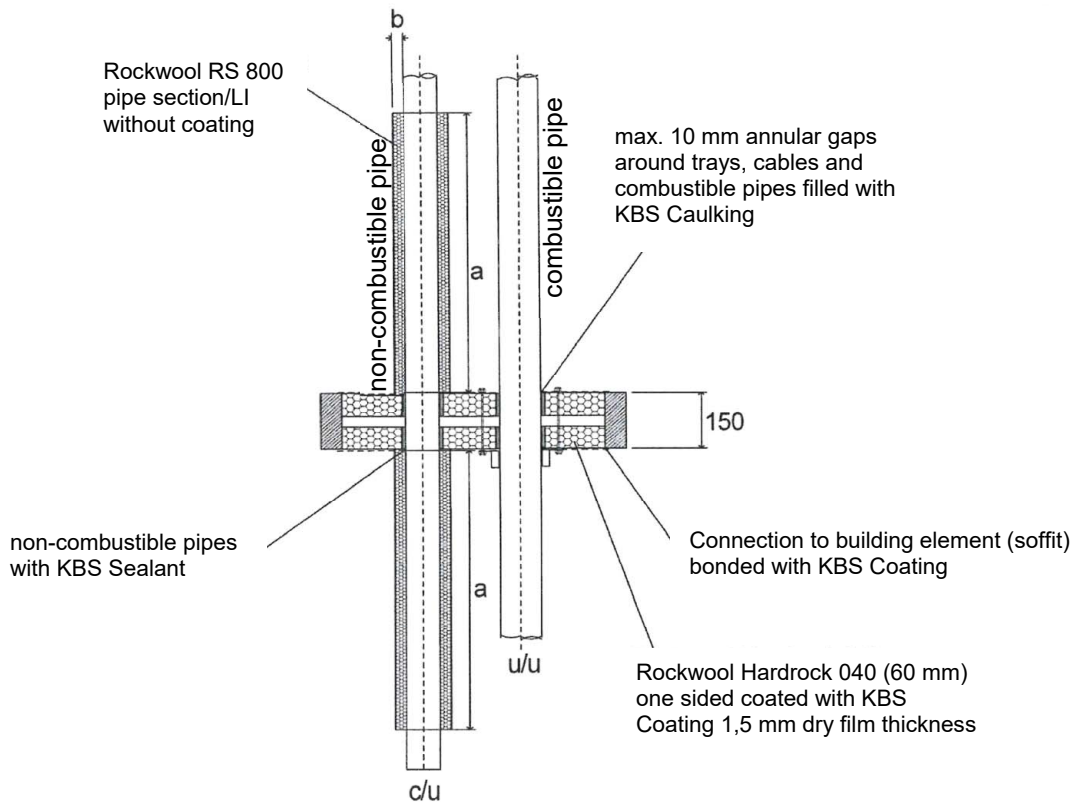
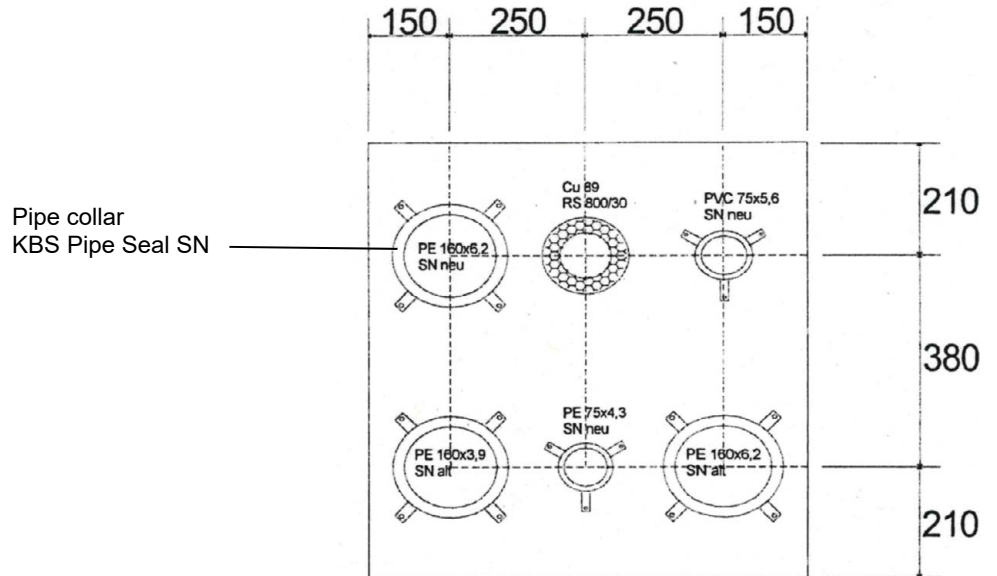

dimensions in mm

KBS Sealant

Use as a component of a multiple pipe penetration seal of resistance to fire class **EI 120**
Layout of the test specimen in the floor – seal thickness: 150 mm

Annex 5