

Approval body for construction products
and types of construction

Bautechnisches Prüfamt

An institution established by the Federal and
Laender Governments



European Technical Assessment

ETA-09/0161
of 4 March 2024

English translation prepared by DIBt - Original version in German language

General Part

Technical Assessment Body issuing the
European Technical Assessment:

Deutsches Institut für Bautechnik

Trade name of the construction product

Stair with load-bearing handrail System Hasler

Product family
to which the construction product belongs

Prefabricated stair kits

Manufacturer

Hasler Treppentechnik AG
Ober Au 28
9487 GAMPRIN-BENDERN
FÜRSTENTUM LIECHTENSTEIN

Manufacturing plant

Hasler Treppentechnik Plant 1-99

This European Technical Assessment
contains

19 pages including 3 annexes which form an integral part
of this assessment

This European Technical Assessment is
issued in accordance with Regulation (EU)
No 305/2011, on the basis of

EAD 340006-00-0506

This version replaces

ETA-09/0161 issued on 8 May 2019

The European Technical Assessment is issued by the Technical Assessment Body in its official language. Translations of this European Technical Assessment in other languages shall fully correspond to the original issued document and shall be identified as such.

Communication of this European Technical Assessment, including transmission by electronic means, shall be in full. However, partial reproduction may only be made with the written consent of the issuing Technical Assessment Body. Any partial reproduction shall be identified as such.

This European Technical Assessment may be withdrawn by the issuing Technical Assessment Body, in particular pursuant to information by the Commission in accordance with Article 25(3) of Regulation (EU) No 305/2011.

Specific Part

1 Technical description of the product

The Stair with load-bearing handrail system Hasler is a prefabricated stair system, which consists of steps, a railing (consisting of handrail, posts and balusters), fasteners, load-bearing bolts and wall ties. The stair can also be formed as a folded plate stair by additional risers.

On the wall-free side the steps are connected with each other by a load-bearing bolt and via balusters with the load-bearing handrail. On the wall side each step is equipped with two wall ties which are anchored in the staircase wall. Alternatively, the staircase wall may also be replaced by a stringer or as on the wall-free side by a load-bearing handrail. In the area of openings in the staircase wall a steel beam (wall-replacement-beam according to Annex A5) can be used.

The steps, the handrail and the posts are made of solid wood, the balusters and distance sleeves are made of steel or solid wood and the fasteners, load-bearing bolts and wall ties are made of steel.

The product description is given in Annex A. The material values, dimensions and tolerances of the components of the stair not indicated in the annexes shall correspond to the values laid down in the technical documentation¹.

2 Specification of the intended use in accordance with the applicable European Assessment Document

The performances given in Section 3 are only valid if the stair is used in compliance with the specifications and conditions given in Annex B.

The verification and assessment methods on which this European Technical Assessment is based lead to the assumption of a working life of the stair of at least 50 years. The indications given on the working life cannot be interpreted as a guarantee given by the producer, but are to be regarded only as a means for choosing the right products in relation to the expected economically reasonable working life of the works.

¹ The technical documentation comprises all information of the holder of this ETA necessary for the production, installation and maintenance of the stair; these are in particular the structural analysis, design drawings and the manufacturer's installation instructions. The part to be treated confidentially is deposited with Deutsches Institut für Bautechnik and, as far as this is relevant to the tasks of the approved bodies involved in the procedure of the AVCP system, shall be handed over to the approved body.

3 Performance of the product and references to the methods used for its assessment

3.1 Mechanical resistance and stability (BWR 1)

Essential characteristic	Performance
Load-bearing capacity <ul style="list-style-type: none"> - Load-bearing capacity of the stair - Load-bearing capacity of components of the stair - Load-bearing capacity of fixings 	Q_{Rk} , q_{Rk} and h_{Rk} : See Annex C2 H_{Rk} : No performance assessed M_{Rk} , V_{Rk} , N_{Rk} , E , G , f_{mk} and f_{vk} : See technical documentation of this European Technical Assessment See technical documentation of this European Technical Assessment
Load-Displacement behaviour	w_q and w_Q : See Annex C2
Vibration behaviour	First natural frequency: $f_1 \geq 5$ Hz Deflection under a single load $F = 1$ kN: $w_{Q1} \leq 5$ mm
Prevention of progressive collapse	Failure of individual components of the stair does not lead to a progressive collapse of the complete stair
Residual load-bearing capacity	Local material failure does not lead to an abrupt total loss of load-bearing capacity of the stair
Long-term behaviour	Load-bearing capacity are ensured under an appropriate use and maintenance over the indicated working life
Resistance to earthquakes	No performance assessed
Durability against physical, chemical, biological agents	Adequate durability for the intended use under an appropriate use and maintenance

3.2 Safety in case of fire (BWR 2)

Essential characteristic	Performance
Reaction to fire	See Annex A9 and A10
Resistance to fire	No performance assessed

3.3 Hygiene, health and the environment (BWR 3)

Essential characteristic	Performance
Release of formaldehyde	Wood adhesive does not contain formaldehyde
Release of pentachlorophenol	No pentachlorophenol contained
Radioactive emission	No performance assessed

English translation prepared by DIBt

3.4 Safety in use (BWR 4)

Essential characteristic	Performance
Geometry	See Annex C1
Slipperiness	No performance assessed
Safety equipment	Barrier and handrail are components of the stair (see Annexes A2 to A3 and C1) If vertical balusters, arranged between step and handrail, used as fill-in elements, a climb ability for infants will not be supported Tactility and visibility: No performance assessed
Safe breakage	No brittle failure of individual components
Impact resistance	No performance assessed

4 Assessment and verification of constancy of performance (AVCP) system applied, with reference to its legal base

In accordance with the European Assessment Document EAD No. 340006-00-0506 the applicable European legal act is: 1999/89/EC

The System to be applied is: 2+

In addition, with regard to reaction to fire for products covered by the European Assessment Document EAD No. 340006-00-0506 the applicable European legal act is: 2001/596/EC

The System to be applied is: 4

5 Technical details necessary for the implementation of the AVCP system, as provided for in the applicable European Assessment Document

Technical details necessary for the implementation of the AVCP system are laid down in the control plan deposited at Deutsches Institut für Bautechnik.

Issued in Berlin on 4 March 2024 by Deutsches Institut für Bautechnik

Dipl.-Ing. Beatrix Wittstock
Head of Section

beglaubigt:
Stiller

English translation prepared by DIBt

Types of plan

Walking line is exemplified, position may be chosen freely within the walking zone, walking zone is 20% of the clear width of the stair in the middle of the stair

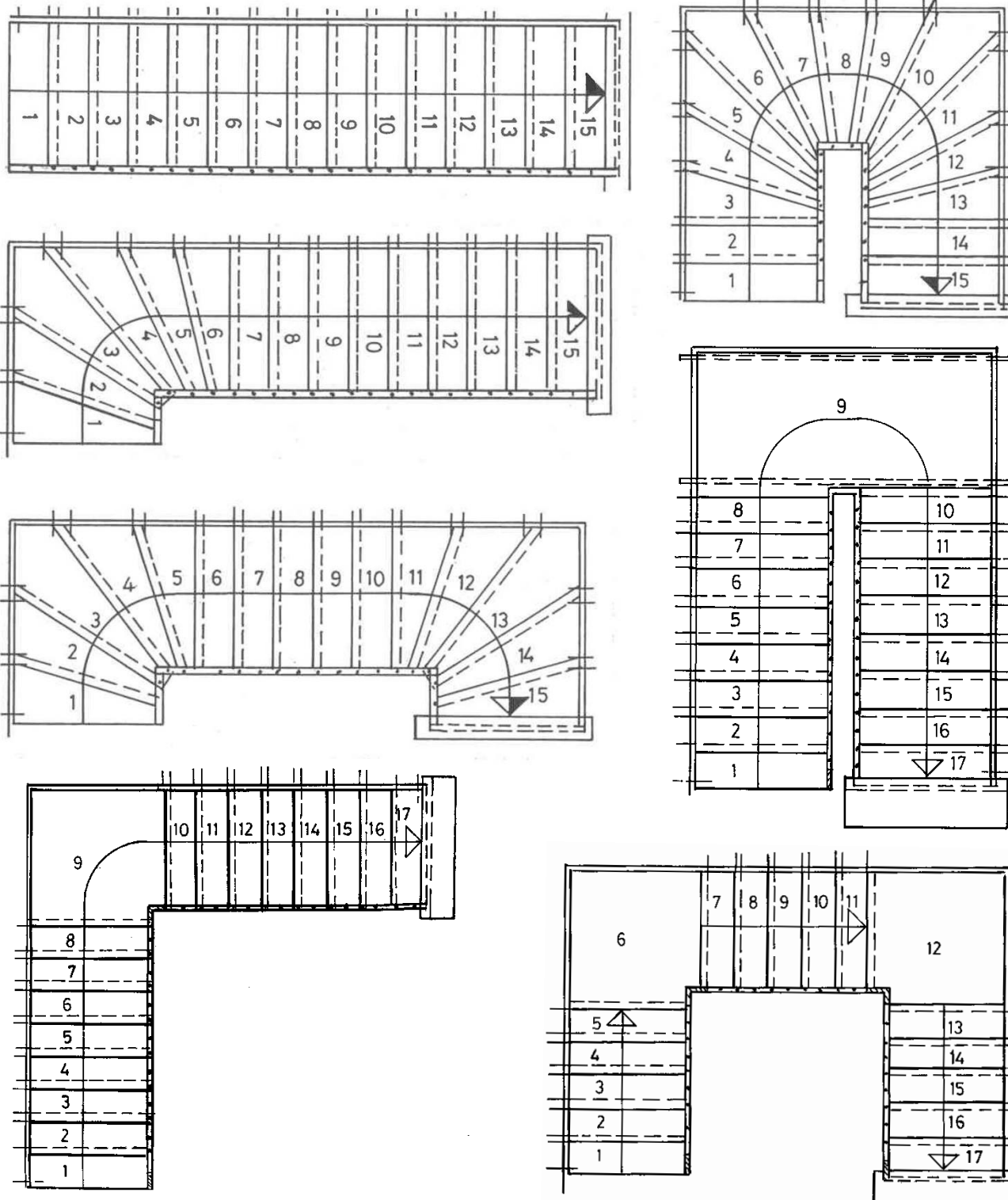

Stair with load-bearing handrail system Hasler

Product (Types of plan)

Annex A1

Types of Construction

Stair in load-bearing bolt style

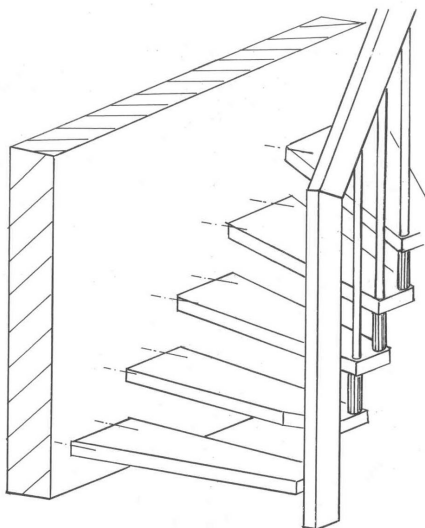

Stair in folded plate style

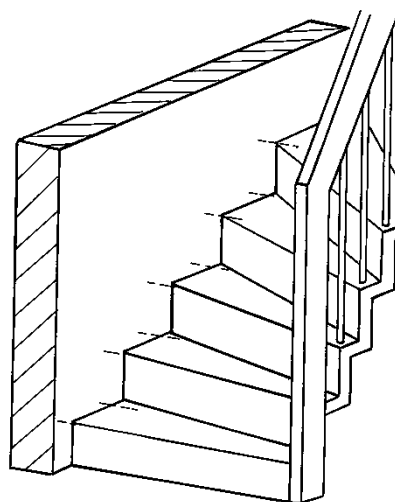

Stair with wall string

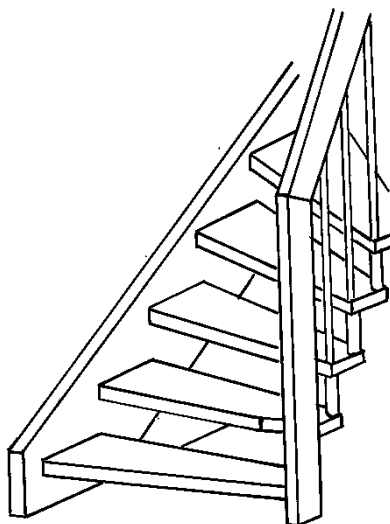

Construction with railing barrier

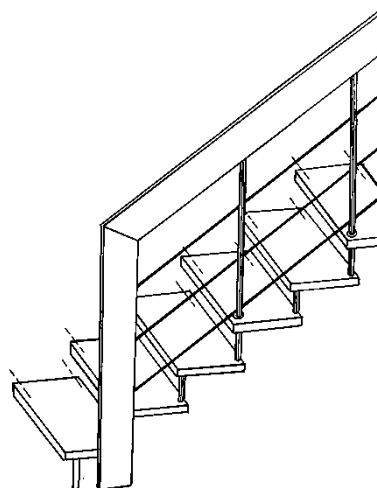

Stair with load-bearing handrail system Hasler

Product (Types of construction)

Annex A2

Balustrade

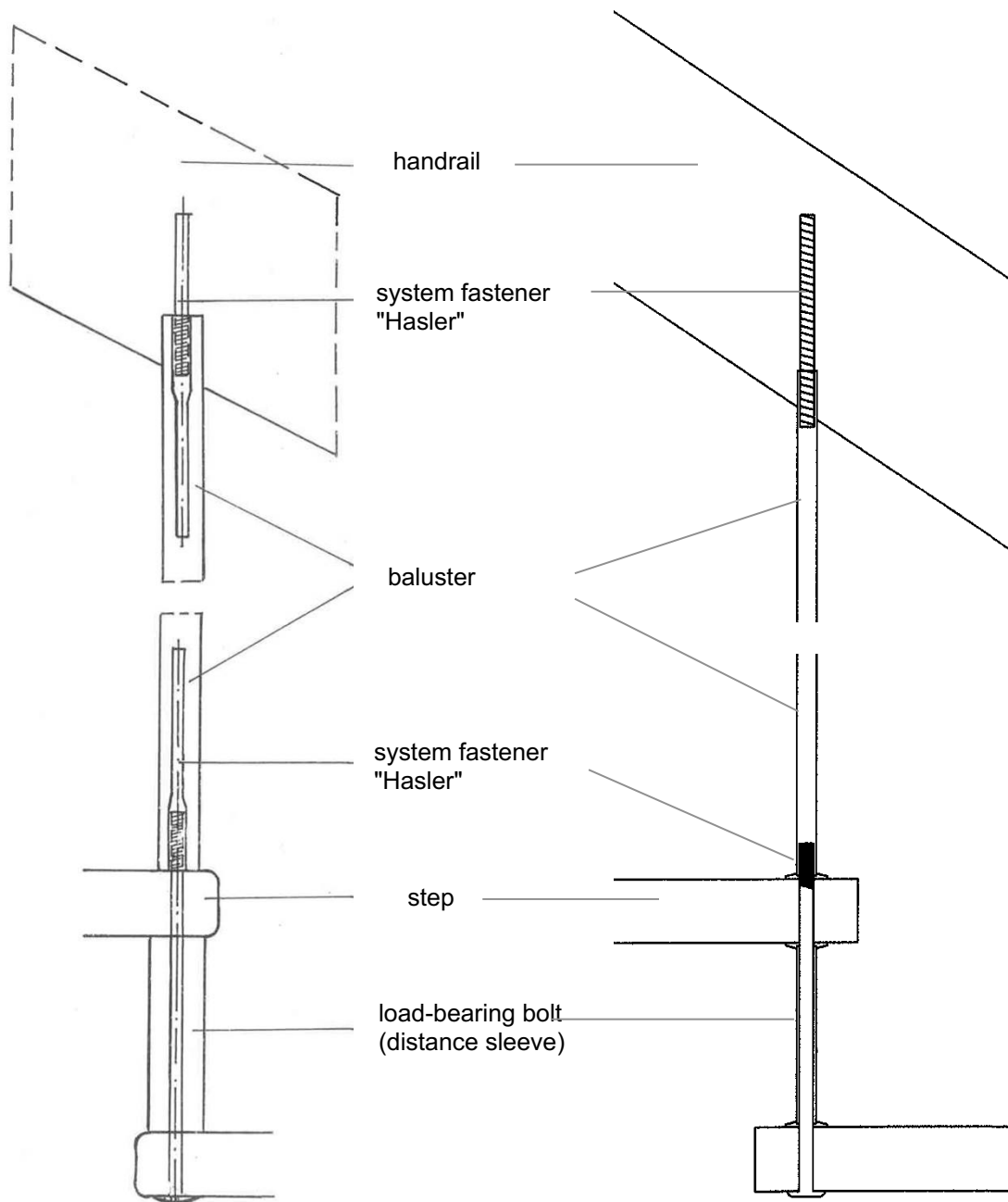

more details according to technical documentation

Stair with load-bearing handrail system Hasler

Balustrade

Annex A3

Wall tie

Type 1

for masonry, concrete and OSB-plate

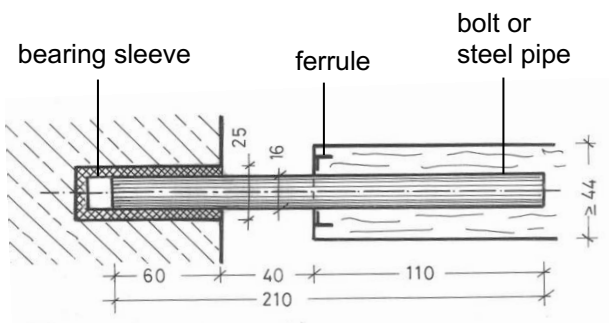

Type 2

for masonry and concrete

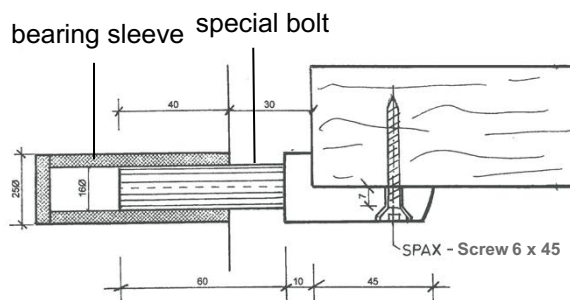

(not for steps made of wood species nut tree)

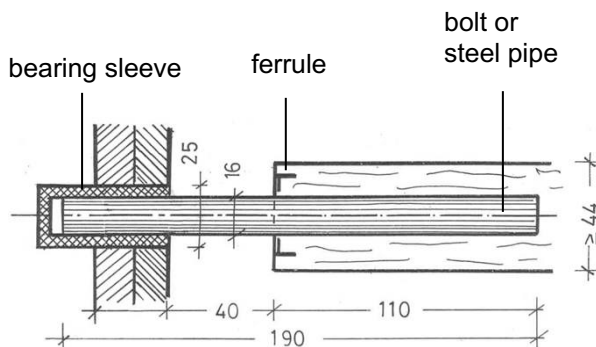

steps made of wood species oak,
nut tree, ash, merbau:
additional steel plate

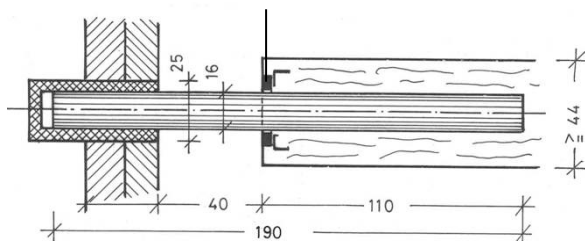

more details according to the technical documentation

all dimensions in mm

Stair with load-bearing handrail system Hasler

Wall tie

Annex A4

**Post – handrail – joint
screwed**

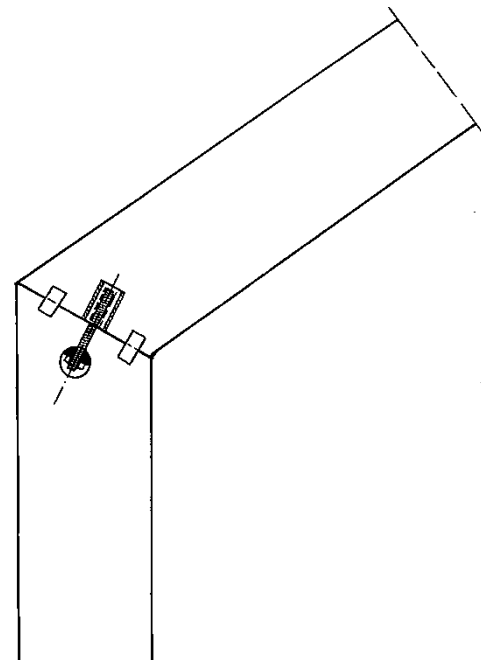

**Post – handrail – joint
finger jointed**

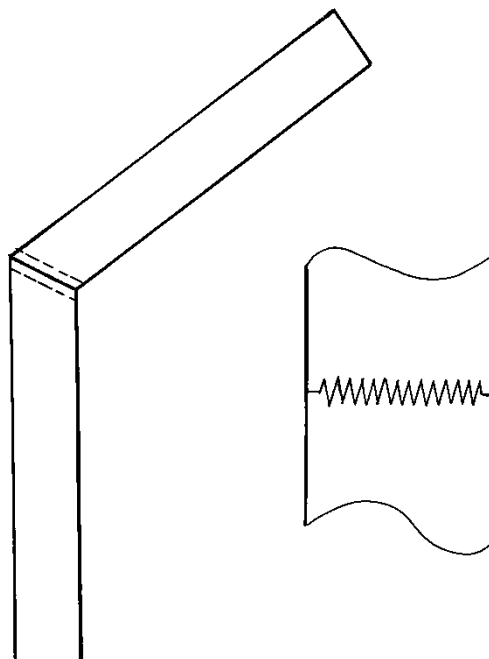

**Post – handrail – joint
screwed**

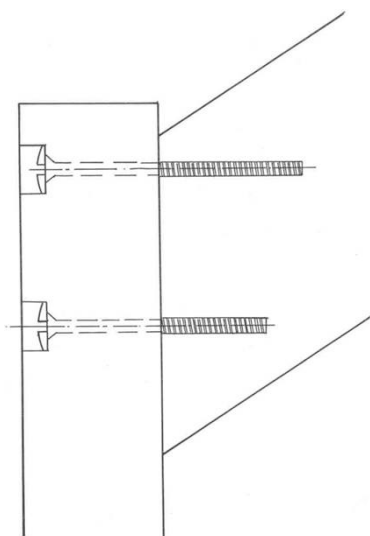

**Handrail corner – joint
screwed**

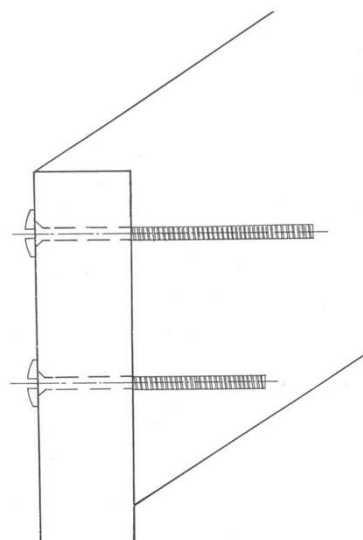

more details according to the technical documentation

Stair with load-bearing handrail system Hasler

Post – handrail – joint
Handrail corner – joint

Annex A5

Post joint at bottom

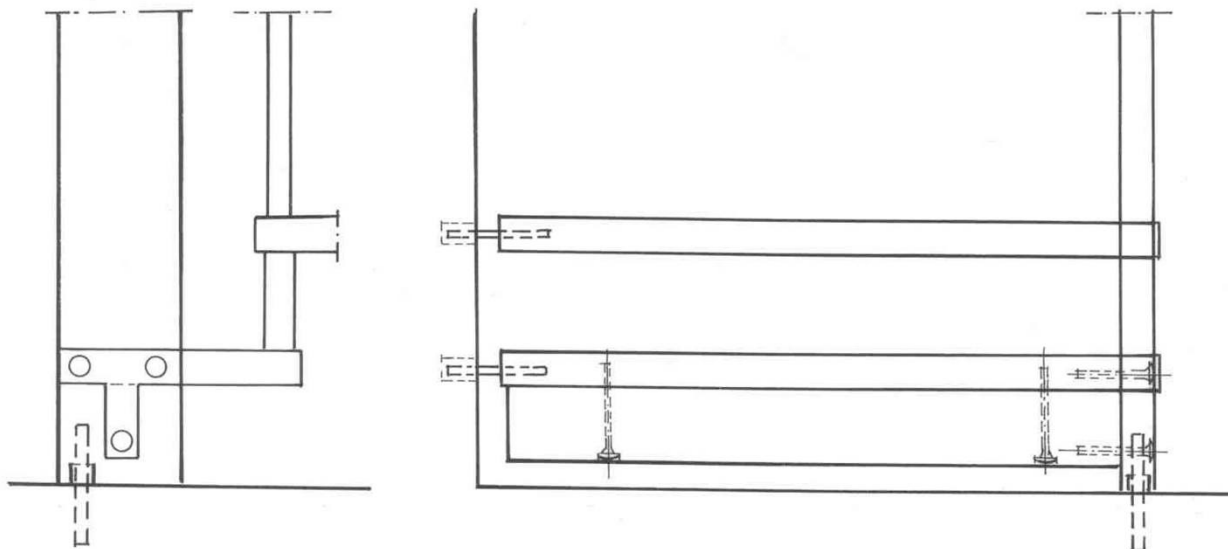

Post joint at the top

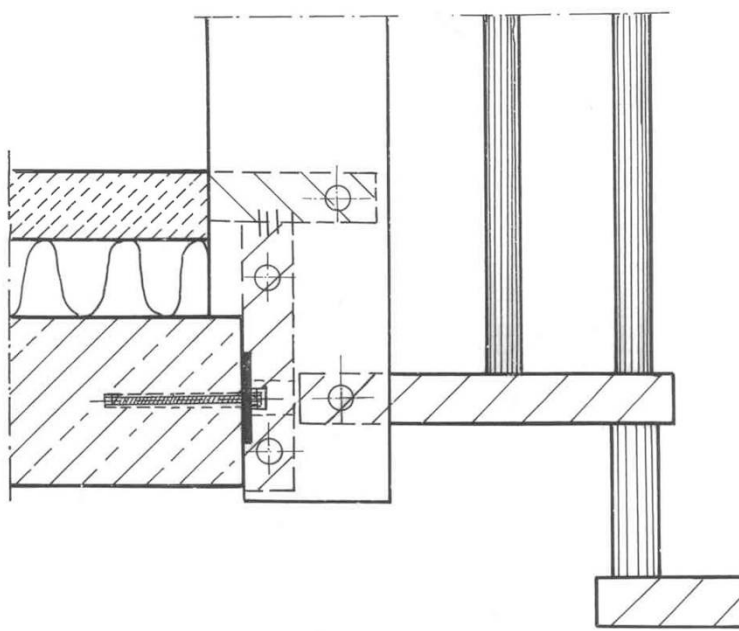

more details according to the technical documentation

Stair with load-bearing handrail system Hasler

Post joint at bottom and Post joint at the top

Annex A6

Wall-replacement-beam made of steel

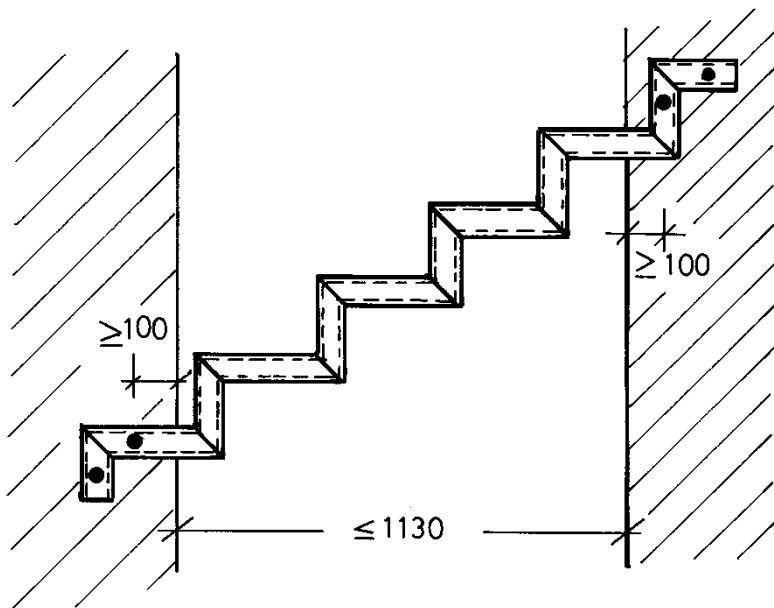

Support Type A

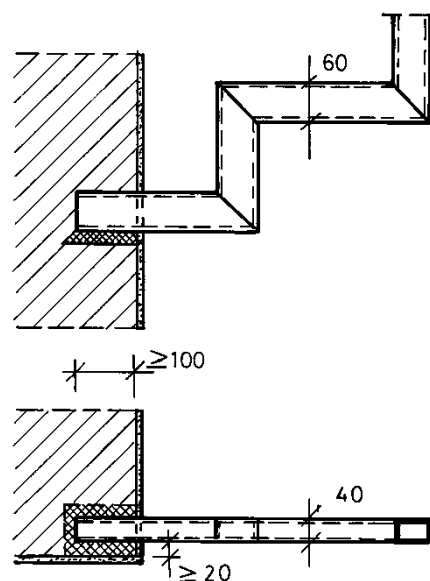

Support Type B

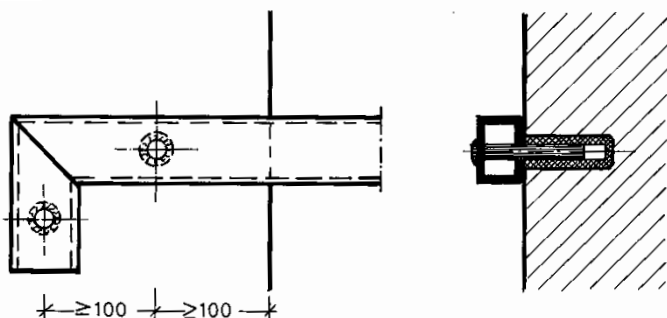

Support Type C

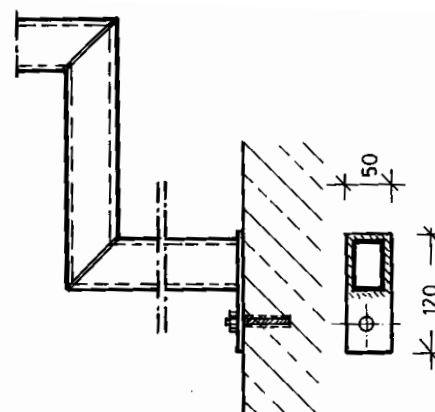

Step - beam - joint (bolt)

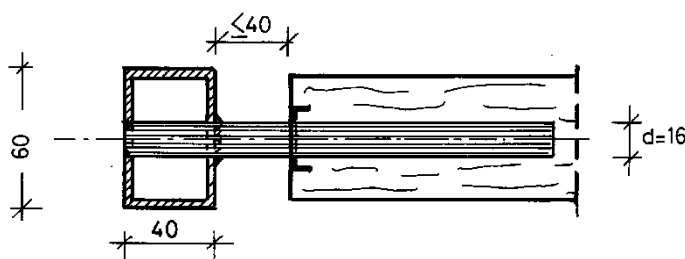

Step - beam – joint (screwed)

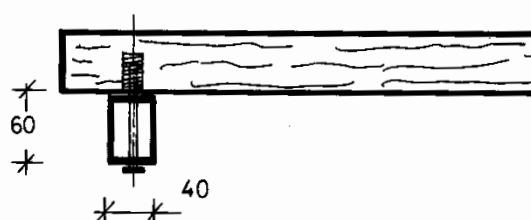

more details according to the technical documentation

all dimensions in mm

Stair with load-bearing handrail system Hasler

Wall replacement beam made of steel

Annex A7

Wall string made of wood

Connection to wall with distance $e \leq 800$ mm

Connection at wood frame wall

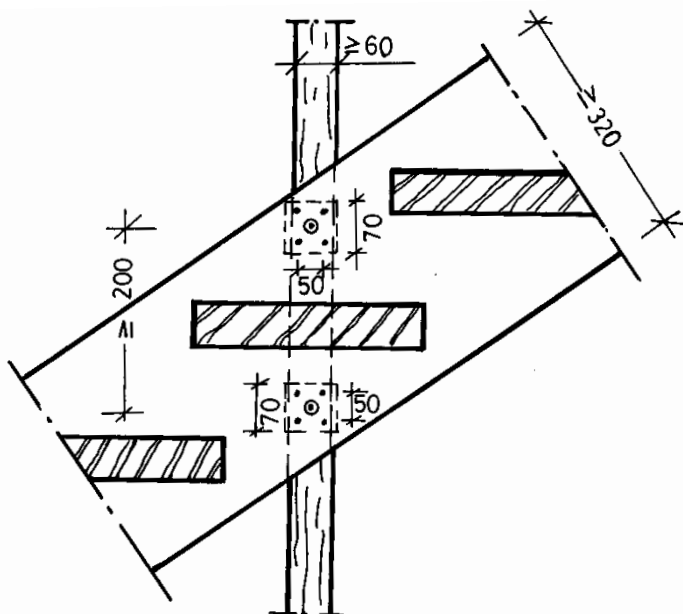

Connection at masonry wall

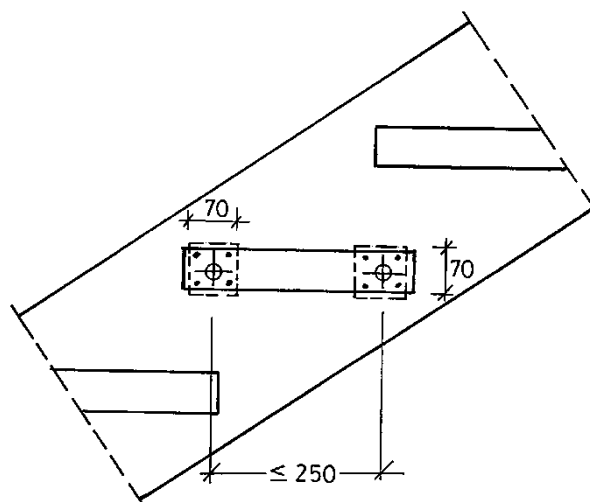

Connection at concrete wall

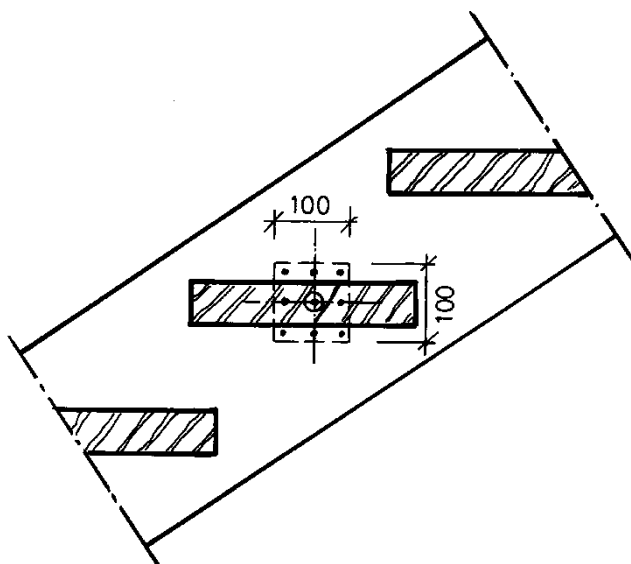

Step – string - joint

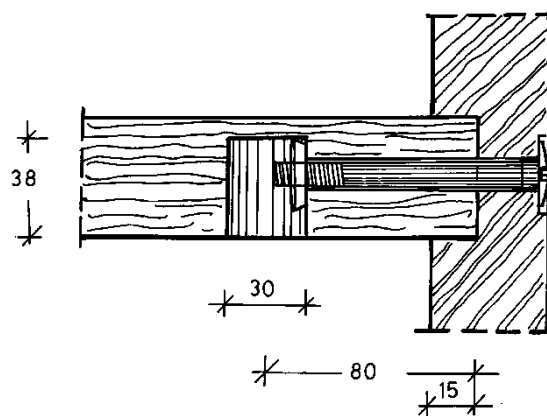

more details according to the technical documentation

all dimensions in mm

Stair with load-bearing handrail system Hasler

Wall string made of wood

Annex A8

Table 1a: Minimum dimensions of relevant stair components and reaction to fire

Component of stair		Material ¹⁾	Dimension		Value	Reaction to fire
step		solid wood ²⁾	thickness	[mm]	44 (40) ⁶⁾	D-s2, d0
upper flange of the railing (handrail)	straight flights only finger jointed	solid wood ²⁾	height / width	[mm]	160 / 53 (45) ³⁾	D-s2, d0
	other flights	solid wood ²⁾	height / width	[mm]	160 / 45	
posts	straight flights only finger jointed	solid wood ²⁾	height / width	[mm]	160 / 53 (45) ³⁾	D-s2, d0
	other flights	solid wood ²⁾	height / width	[mm]	160 / 45 80 / 80	
baluster		solid wood ²⁾	diameter	[mm]	30	D-s2, d0
		steel	diameter	[mm]	10	A1
		steel pipe	diameter	[mm]	16 (30) ⁷⁾	A1
load-bearing bolt / system fastener		steel	diameter	[mm]	10	A1
distance sleeve (load-bearing bolt)		solid wood ²⁾	diameter	[mm]	40	D-s2, d0
		steel	pipe	[mm]	16 x 2	A1
washer (load-bearing bolt)		steel	diameter / thickness	[mm]	40 / 4	A1
wall ties		round steel or steel pipe	diameter	[mm]	16	A1
			diameter / wall thickness	[mm]	16 / 2.0	
			embedment depth wall (type 1)	[mm]	60 (32) ⁴⁾	
			embedment depth wall (type 2)	[mm]	40	
			embedment depth step (type 1)	[mm]	110	
bearing sleeve (wall tie)		plastic	diameter	[mm]	25	not relevant

- 1) characteristic values of material according to technical documentation
- 2) only hardwood of the following species: beech, oak, maple, acacia, nut tree, ash, merbau
- 3) value in brackets, if handrail is horizontal fixed in height of the floor slab
- 4) value in brackets for OSB-wall
- 5) according to technical documentation
- 6) value in brackets only for wall tie Type 2
- 7) value in brackets only for railing baluster

Stair with load-bearing handrail system Hasler

Minimum dimensions of relevant stair components and reaction to fire

Annex A9

Table 1b: Minimum dimensions of relevant stair components and reaction to fire

Component of stair	Material ¹⁾	Dimension		Value	Reaction to fire
wall-replacement-beam	steel hollow section	height / width / wall thickness	[mm]	60 / 40 / 4	A1
wall string	solid wood ²⁾	height / width	[mm]	320 / 45	D-s2, d0
landing beam	solid wood	- ³⁾	-	- ³⁾	D-s2, d0
	steel hollow section	- ³⁾	-	- ³⁾	A1

¹⁾ characteristic values of material according to technical documentation

²⁾ only hardwood of the following species: beech, oak, maple, acacia, nut tree, ash, merbau

³⁾ according to technical documentation

Stair with load-bearing handrail system Hasler

Minimum dimensions of relevant stair components and reaction to fire

Annex A10

Specification of intended use (Part 1)

Intended use:

- European Technical Assessment applies for a construction system
- For the specific case of use the corresponding type of stair is manufactured within the context of the values defined in this European Technical Assessment
- Values of this ETA applies to all types of stairs according to Annex A1 and A2; the real dimensions follow in accordance with the relevant case of use

Stair subject to:

- Static and quasi static loads

Use conditions:

- Indoor stair
- Air temperatures between +5 °C and +30 °C
- Relative air humidity between 30% and 70%

Design:

- Design of the stair according to the annexes and the technical documentation of this European Technical Assessment
- Fastening of the stair to the construction works according to the annexes and the technical documentation of this Technical European Assessment
- Verification of the transmission of loads to the construction works by the civil engineer responsible for the construction works
- Load bearing capacity at ultimate limit state:

$$q_k \cdot \gamma_Q \leq q_{Rk} / \gamma_M$$

$$Q_k \cdot \gamma_Q \leq Q_{Rk} / \gamma_M$$

$$h_k \cdot \gamma_Q \cdot \psi_0 \leq h_{Rk} / \gamma_M$$

with

q_{Rk} , Q_{Rk} , h_{Rk} : characteristic values of resistance; see Table 3

γ_M : recommended material partial safety factor; see Table 3

q_k , Q_k , h_k : characteristic values of imposed loads according to EN 1991-1-1:2002 + AC:2009

$\gamma_Q = 1.5$: recommended partial safety factor, in absence of other national regulations

$\psi_0 = 0.7$: recommended combination factor, in absence of other national regulations

- Maximum characteristic values of imposed loads under consideration of the partial factors mentioned above; see Table 5

Stair with load-bearing handrail system Hasler

Specification of intended use (Part 1)

Annex B1

Specification of intended use (Part 2)

Installation:

- Installation by personal appropriately trained and authorized by the manufacturer by means of the technical documentation of this European Technical Assessment
- Installation only in the way as specified in the technical documentation of this European Technical Assessment
- Installation of timber components when moisture content of timber components is $8 \pm 2 \%$
- Sufficient support of the stair when assembling
- Installation of stair components without imposed deformations
- Installation of stair components without significant defects and cracks
- Replacing of stair components, which begin tearing when assembling
- Bolted connections are protected such that they will not be loosened by vibrations

Indication of the manufacturer:

- Ensure that all persons involved will be appropriately informed about the specific conditions according to sections 1 and 2 (including the annexes to which reference is being made as well as the not confidential parts of the technical documentation deposited to this European Technical Assessment)
- Packaging of timber components such that the wood moisture is $8 \pm 2 \%$ during transport and storage
- Instructions for use should provide information as to use, maintenance and repair of the stair. Including the information of avoidance of moisture penetration of the timber components and of retightens the bolting of the load-bearing bolts and connections according to Annex A after the first heating season

Stair with load-bearing handrail system Hasler

Specification of intended use (Part 2)

Annex B2

Table 2: Geometry

Designation			Dimension	
			minimum	maximum
going	step on walking line ¹⁾	[mm]	210	370 ²⁾
	tapered step	[mm]	60 ^{2) 3)}	540 ^{2) 4)}
rise of the stairs ¹⁾		[mm]	140 ²⁾	210
pitch of the walking line ¹⁾		[°]	21	45
overlap of steps	wall side	[mm]	30	- ⁵⁾
	wall-free side	[mm]	60	- ⁵⁾
number of rises		[-]	3	16 (18) ⁷⁾
openings	between barrier and other parts of the stair	[mm]	0	0
	between stairs and wall	[mm]	- ⁵⁾	40 (30) ⁶⁾
	between consecutive steps	[mm]	- ⁵⁾	166
	between balusters	[mm]	40	550
clear width of stairs		[mm]	500	1000
minimum headroom		[mm]	- ⁵⁾	
length of the flight		[mm]	- ⁵⁾	3900
thickness of steps		[mm]	44 (40) ⁶⁾	- ⁵⁾
upper flange of the railing / handrail		[mm]	900	1000
handrail	width	[mm]	45	53
	height	[mm]	160	- ⁵⁾
	clear distance to adjacent components	[mm]	50	- ⁵⁾

- 1) values are constant within one flight
- 2) tolerance between nominal value and actual value = ± 5 mm
- 3) inside of tapered step
- 4) outside of tapered step
- 5) not relevant
- 6) value in brackets only for wall tie Type 2
- 7) value in brackets for stairs with landing

- 1 going
- 2 rise
- 3 overlap
- 4 opening between consecutive steps
- 5 length of the flight
- 6 thickness of steps
- 7 height of the railing / barrier
- 8 opening between balusters

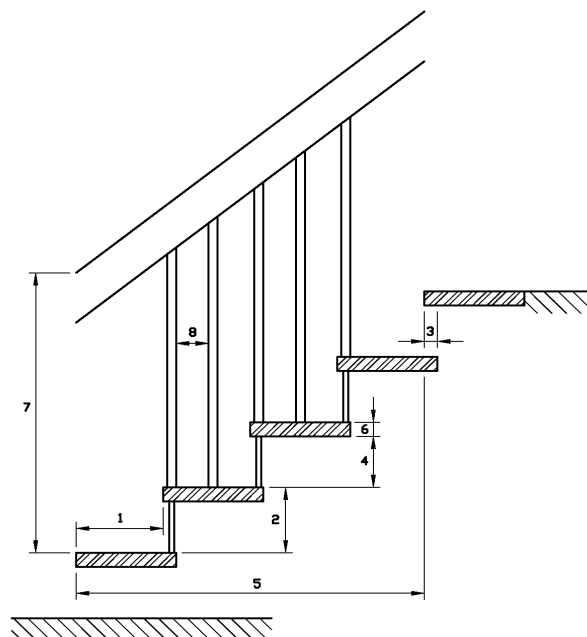

Stair with load-bearing handrail system Hasler

Geometry of the stair

Annex C1

Table 3: Load-bearing capacity – Characteristic values of resistance

Component	Type of loading	Characteristic values of resistance			γ_M
Flight	vertical variable uniformly distributed load	q_{Rk}	[kN/m ²]	6,8	1,5 ¹⁾
	vertical variable single load	Q_{Rk}	[kN]	4,5	
	horizontal variable uniformly distributed load on barrier	h_{Rk}	[kN/m]	0,8	
Wall-replacement-beam / Landing beam	vertical variable uniformly distributed load	q_{Rk}	[kN/m ²]	5,0	1,1 ²⁾
	vertical variable single load	Q_{Rk}	[kN]	3,3	
	horizontal variable uniformly distributed load on barrier	h_{Rk}	[kN/m]	0,6	

1) Recommended partial safety factor (wood decisive), in absence of other national regulations

2) Recommended partial safety factor (steel decisive), in absence of other national regulations

Table 4: Deflections under loading

Deflection of the flight under uniformly distributed load			
uniformly distributed load	q_k	[kN/m ²]	3,0
length of the median line of the flight	L	[mm]	3900
deflection related to the median line of the flight	w_q	[mm]	≤ L/200
Deflection of the step under single point load			
single load	Q_k	[kN]	2,0
clear width of the stair	L	[mm]	1000
deflection related to the clear width of the stair	w_Q	[mm]	≤ L/200

Table 5: Imposed loads

Type of loading	Imposed loads		
vertical variable uniformly distributed load	q_k	[kN/m ²]	3,0
vertical variable single load	Q_k	[kN]	2,0
horizontal variable uniformly distributed load on barrier	h_k	[kN/m]	0,5

Stair with load-bearing handrail system Hasler

Load-bearing capacity – Characteristic values of resistance,
Deflections under loading,
Imposed loads

Annex C2